



srivenkateshwaraa
College of Engineering & Technology
(Approved by AICTE, New Delhi & Affiliated to Pondicherry University, Puducherry)
13-A, Pondy - Villupuram Main Road, Ariyur, Puducherry - 605 102.

ASPIRE TO EXCEL



DEPARTMENT OF MECHANICAL ENGINEERING

SUBJECT NOTES

SUB NAME: HEAT AND MASS TRANSFER

SUBCODE : MET54

YEAR & SEM : III/V

PREPARED BY,

Mr.R.KAMALANATHAN M.E.,

ASSISTANT PROFESSOR

SVCET

UNIT - 1

Introduction

However a temperature difference exists within a system or when two systems at different temperatures are brought into contact, energy is transferred. The process by which the energy transport takes place is known as heat transfer. Heat cannot be measured or observed directly, but the effect it produces is amenable to observation and measurement.

Difference between heat and temperature

In describing heat transfer problems, we often make the mistake of interchangeably using the terms heat and temperature. Actually, there is a distinct difference between the two. Temperature is a measure of the amount of energy possessed by the molecules of a substance. It is a relative measure of how hot or cold a substance is and can be used to predict the direction of heat transfer. The usual symbol for temperature is T . The scales for measuring temperature in SI units are the Celsius and Kelvin temperature scales. On the other hand, heat is energy in transit. The transfer of energy as heat occurs at the molecular level as a result of a temperature difference. The usual symbol for heat is Q . Common units for measuring heat are the Joule and calorie in the SI system.

Difference between thermodynamics and heat transfer

Thermodynamics tells us:

- How much heat is transferred (δQ)
- How much work is done (δW)
- Final state of the system

Heat transfer tells us:

- How (with what **modes**) δQ is transferred
- At what **rate** δQ is transferred
- Temperature distribution inside the body

Modes of heat transfer

Conduction :Heat conduction is a mechanism of heat transfer from a region of high temperature to a region of low temperature within a medium or between different medium in direct physical contact. Examples: Heating a Rod.

Convection: It is a process of heat transfer that will occur between a solid surface and a fluid medium when they are at different temperatures. It is possible only in the presence of fluid medium.

Example: Cooling of Hot Plate by air

Radiation: The heat transfer from one body to another without any transmitting medium. It is an electromagnetic wave phenomenon.

Example: Radiation sun to earth.

Basic laws of heat transfer governing conduction

Basic law of governing conduction: This law is also known as Fourier's law of conduction.

The rate of heat conduction is proportional to the area measured normal to the direction of heat flow and to the temperature gradient in that direction

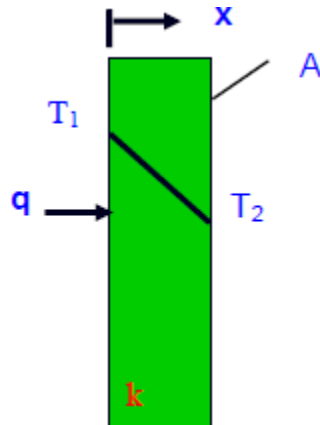

$$Q \propto -A \frac{dt}{dx}$$

$$Q = -KA \frac{dt}{dx}$$

Where, A – Area in m²

$\frac{dt}{dx}$ – Temperature gradient, K /m

K – Thermal conductivity, W/mk

Basic law of governing convection: This law is also known as Newton's law of convection.

An energy transfer across a system boundary due to a temperature difference by the combined mechanisms of intermolecular interactions and bulk transport. Convection needs fluid matter.

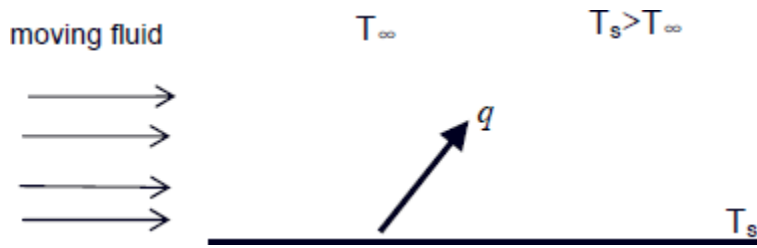

Newton's Law of Cooling:

$$q = hA_s\Delta T$$

Where:

q = heat flow from surface, a scalar, (W)

h = heat transfer coefficient (which is not a thermodynamic property of the material, but may depend on geometry of surface, flow characteristics, thermodynamic properties of the fluid, etc. ($\text{W}/\text{m}^2 \text{K}$))

A_s = Surface area from which convection is occurring. (m^2)

$\Delta T = T_s - T_\infty$ = Temperature Difference between surface and coolant. (K)

Basic law of governing radiation: This law is also known as Steffan Boltzman law.

According to the Steffan Boltzman law the radiation energy emitted by a body is proportional to the fourth power of its absolute temperature and its surface area.

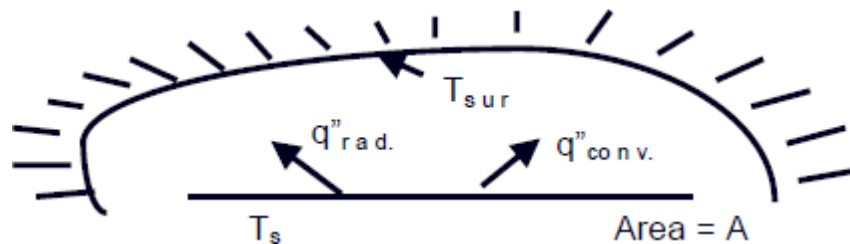

$$q = \varepsilon\sigma A(T_s^4 - T_{sur}^4)$$

Where:

ε = Surface Emissivity

σ = Steffan Boltzman constant

A = Surface Area

T_s = Absolute temperature of surface. (K)

T_{sur} = Absolute temperature of surroundings. (K)

Thermal conductivity: Thermal conductivity is a thermodynamic property of a material “the amount of energy conducted through a body of unit area and unit thickness in unit time when the difference in temperature between faces causing heat flow is unit temperature difference”.

Derivation of general three dimensional conduction equation in Cartesian coordinate

Consider a small rectangular element of sides dx , dy and dz as shown in figure. The energy balance of this rectangular element is obtained from first law of thermodynamics

Consider the differential control element shown below. Heat is assumed to flow through the element in the positive directions as shown by the 6 heat vectors.

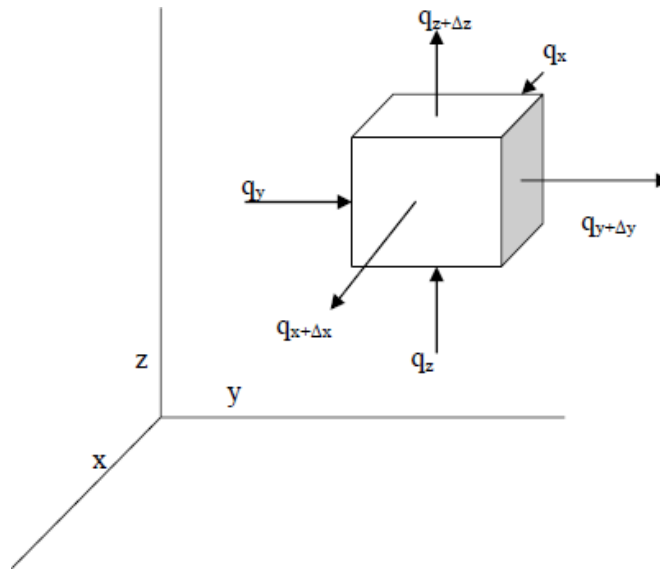

In the equation above we substitute the 6 heat inflows/outflows using the appropriate sign:

$$\rho \cdot c_p \cdot (\Delta x \cdot \Delta y \cdot \Delta z) \cdot \left. \frac{dT}{dt} \right|_{\text{system}} = q_x - q_{x+\Delta x} + q_y - q_{y+\Delta y} + q_z - q_{z+\Delta z} + \dot{Q}_{\text{gen}}$$

Substitute for each of the conduction terms using the Fourier Law:

$$\begin{aligned} \rho \cdot c_p \cdot (\Delta x \cdot \Delta y \cdot \Delta z) \cdot \left. \frac{\partial T}{\partial t} \right|_{\text{system}} &= \left\{ -k \cdot (\Delta y \cdot \Delta z) \cdot \frac{\partial T}{\partial x} - \left[-k \cdot (\Delta y \cdot \Delta z) \cdot \frac{\partial T}{\partial x} + \frac{\partial}{\partial x} \left(-k \cdot (\Delta y \cdot \Delta z) \cdot \frac{\partial T}{\partial x} \right) \cdot \Delta x \right] \right\} \\ &+ \left\{ -k \cdot (\Delta x \cdot \Delta z) \cdot \frac{\partial T}{\partial y} - \left[-k \cdot (\Delta x \cdot \Delta z) \cdot \frac{\partial T}{\partial y} + \frac{\partial}{\partial y} \left(-k \cdot (\Delta x \cdot \Delta z) \cdot \frac{\partial T}{\partial y} \right) \cdot \Delta y \right] \right\} \\ &+ \left\{ -k \cdot (\Delta x \cdot \Delta y) \cdot \frac{\partial T}{\partial z} + \left[-k \cdot (\Delta x \cdot \Delta y) \cdot \frac{\partial T}{\partial z} + \frac{\partial}{\partial z} \left(-k \cdot (\Delta x \cdot \Delta y) \cdot \frac{\partial T}{\partial z} \right) \cdot \Delta z \right] \right\} \\ &+ \ddot{q} \cdot (\Delta x \cdot \Delta y \cdot \Delta z) \end{aligned}$$

where \ddot{q} is defined as the internal heat generation per unit volume.

The above equation reduces to:

$$\rho \cdot c_p \cdot (\Delta x \cdot \Delta y \cdot \Delta z) \cdot \left. \frac{dT}{dt} \right|_{\text{system}} = \left\{ - \left[\frac{\partial}{\partial x} \left(-k \cdot (\Delta y \cdot \Delta z) \cdot \frac{\partial T}{\partial x} \right) \right] \cdot \Delta x \right\}$$

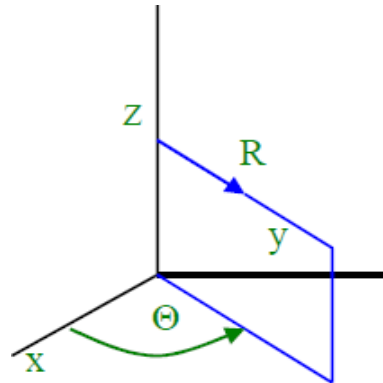
Discussion on 3-D conduction in cylindrical and spherical coordinate systems**Cylindrical coordinate system:**

The 3-Dimensional conduction equation in cylindrical co-ordinates is given by,

$$\frac{1}{a} \cdot \frac{\partial T}{\partial \tau} = \frac{1}{r} \frac{\partial}{\partial r} \left(r \cdot \frac{\partial T}{\partial r} \right) + \frac{1}{r^2} \cdot \frac{\partial^2 T}{\partial \theta^2} + \frac{\partial^2 T}{\partial z^2} + \frac{\dot{q}}{k}$$

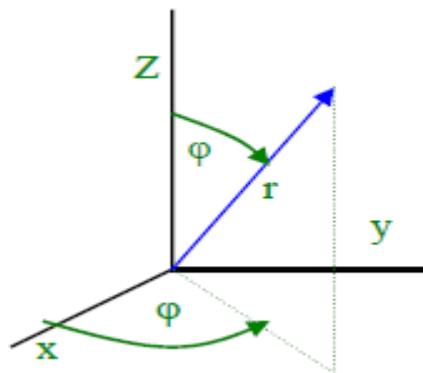
Spherical coordinate systems:

The 3-Dimensional conduction equation in cylindrical co-ordinates is given by,

$$\frac{1}{a} \cdot \frac{\partial T}{\partial \tau} = \frac{1}{r^2} \frac{\partial}{\partial r} \left(r^2 \cdot \frac{\partial T}{\partial r} \right) + \frac{1}{r^2 \cdot \sin^2 \theta} \cdot \frac{\partial^2 T}{\partial \phi^2} + \frac{1}{r^2 \sin \theta} \cdot \frac{\partial}{\partial \theta} \left(\sin \theta \cdot \frac{\partial T}{\partial \theta} \right) + \frac{\dot{q}}{k}$$

In each equation the dependent variable, T, is a function of 4 independent variables, (x,y,z,τ);(r,θ,z,τ); (r,φ,θ,τ) and is a 2nd order, partial differential equation. The solution of such equations will normally require a numerical solution. For the present, we shall simply look at the simplifications that can be made to the equations to describe specific problems.

- **Steady State:** Steady state solutions imply that the system conditions are not changing with time. Thus $\partial T / \partial \tau = 0$.

- One dimensional: If heat is flowing in only one coordinate direction, then it follows that there is no temperature gradient in the other two directions. Thus the two partials associated with these directions are equal to zero.
- Two dimensional: If heat is flowing in only two coordinate directions, then it follows that there is no temperature gradient in the third direction. Thus the partial derivative associated with this third direction is equal to zero.
- No Sources: If there are no heat sources within the system then the term, $q=0$.

Note that the equation is 2nd order in each coordinate direction so that integration will result in 2 constants of integration. To evaluate these constants two additional equations must be written for each coordinate direction based on the physical conditions of the problem. Such equations are termed “boundary conditions”.

Boundary and Initial Conditions:

- The objective of deriving the heat diffusion equation is to determine the temperature distribution within the conducting body.
- We have set up a differential equation, with T as the dependent variable. The solution will give us $T(x,y,z)$. Solution depends on boundary conditions (BC) and initial conditions (IC).
- How many BC's and IC's?
 - Heat equation is second order in spatial coordinate. Hence, 2 BC's needed for each coordinate.
 - 1D problem: 2 BC in x-direction
 - 2D problem: 2 BC in x-direction, 2 in y-direction
 - 3D problem: 2 in x-dir., 2 in y-dir., and 2 in z-dir.
 - Heat equation is first order in time. Hence one IC needed.

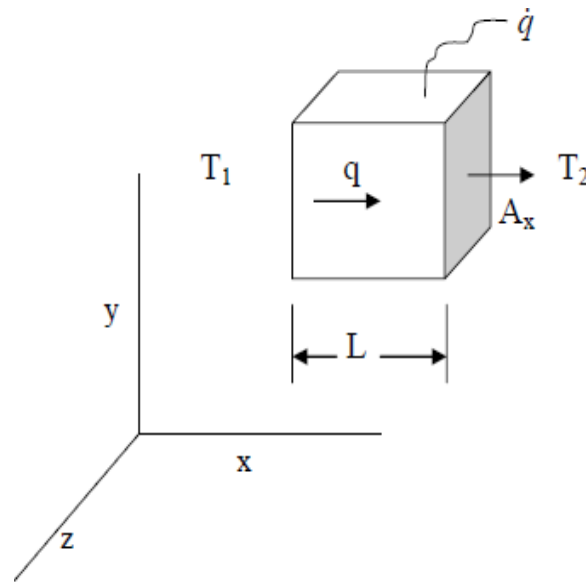
Heat Diffusion Equation for a One Dimensional System:

Consider the system shown above. The top, bottom, front and back of the cube are insulated, so that heat can be conducted through the cube only in the x direction. The internal heat generation per unit volume is \dot{q} (W/m³).

Consider the heat flow through an arbitrary differential element of the cube.

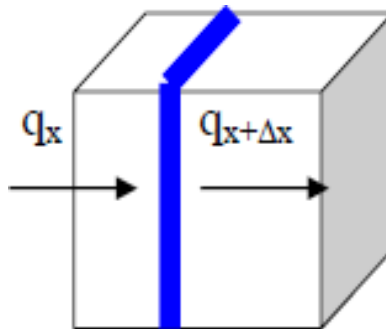

From the 1st Law we write for the element:

$$(\dot{E}_{in} - \dot{E}_{out}) + \dot{E}_{gen} = \dot{E}_{st}$$

$$q_x - q_{x+\Delta x} + A_x(\Delta x)\dot{q} = \frac{\partial E}{\partial t}$$

$$q_x = -kA_x \frac{\partial T}{\partial x}$$

$$q_{x+\Delta x} = q_x + \frac{\partial q_x}{\partial x} \Delta x$$

$$-kA \frac{\partial T}{\partial x} + kA \frac{\partial T}{\partial x} + A \frac{\partial}{\partial x} \left(k \frac{\partial T}{\partial x} \right) \Delta x + A \Delta x \dot{q} = \rho A c \Delta x \frac{\partial T}{\partial t}$$

$$\frac{\partial}{\partial x} \left(k \frac{\partial T}{\partial x} \right) + \dot{q} = \rho c \Delta x \frac{\partial T}{\partial t}$$

Longitudinal
conduction

Internal heat
generation

Thermal inertia

If k is a constant, then
$$\frac{\partial^2 T}{\partial x^2} + \frac{\dot{q}}{k} = \frac{\rho c}{k} \frac{\partial T}{\partial t} = \frac{1}{\alpha} \frac{\partial T}{\partial t}$$

One Dimensional Steady State Heat Conduction: The plane wall:

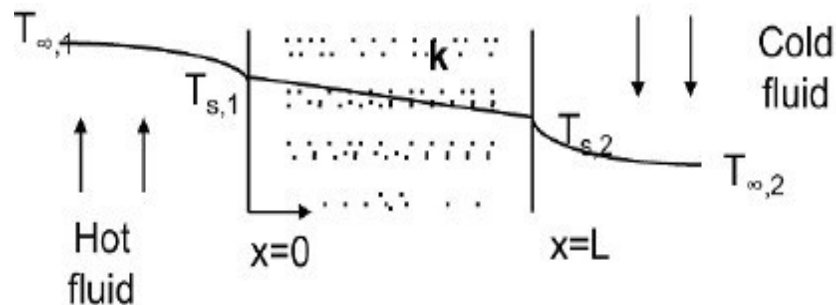

The differential equation governing heat diffusion is: $\frac{d}{dx} \left(k \frac{dT}{dx} \right) = 0$

With constant k , the above equation may be integrated twice to obtain the general solution:

$$T(x) = C_1 x + C_2$$

where C_1 and C_2 are constants of integration. To obtain the constants of integration, we apply the boundary conditions at $x = 0$ and $x = L$, in which case

$$T(0) = T_{s,1} \quad \text{and} \quad T(L) = T_{s,2}$$

Once the constants of integration are substituted into the general equation, the temperature distribution is obtained:

$$T(x) = (T_{s,2} - T_{s,1}) \frac{x}{L} + T_{s,1}$$

The heat flow rate across the wall is given by:

$$q_x = -kA \frac{dT}{dx} = \frac{kA}{L} (T_{s,1} - T_{s,2}) = \frac{T_{s,1} - T_{s,2}}{L/kA}$$

Thermal resistance (electrical analogy):

Physical systems are said to be analogous if that obey the same mathematical equation. The above relations can be put into the form of Ohm's law:

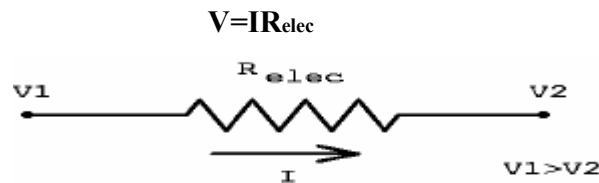

Using this terminology it is common to speak of a thermal resistance:

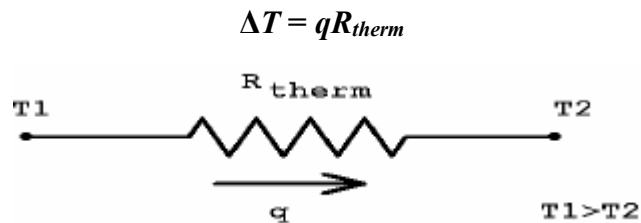

A thermal resistance may also be associated with heat transfer by convection at a surface. From Newton's law of cooling,

$$q = hA(T_s - T_\infty)$$

The thermal resistance for convection is then

$$R_{t,conv} = \frac{T_s - T_\infty}{q} = \frac{1}{hA}$$

Applying thermal resistance concept to the plane wall, the equivalent thermal circuit for the plane wall with convection boundary conditions is shown in the figure below

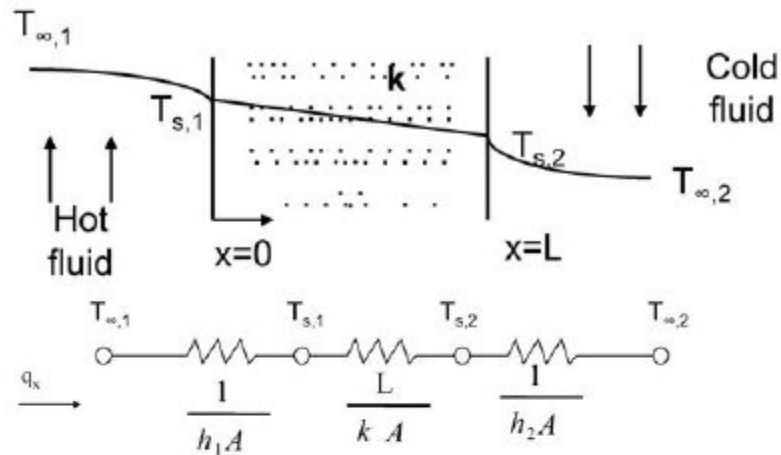

The heat transfer rate may be determined from separate consideration of each element in the network. Since q_x is constant throughout the network, it follows that

$$q_x = \frac{T_{\infty,1} - T_{s,1}}{1/h_1 A} = \frac{T_{s,1} - T_{s,2}}{L/kA} = \frac{T_{s,2} - T_{\infty,2}}{1/h_2 A}$$

In terms of the overall temperature difference $T_{\infty,1} - T_{\infty,2}$, and the total thermal resistance R_{tot} , the heat transfer rate may also be expressed as

$$q_x = \frac{T_{\infty,1} - T_{\infty,2}}{R_{tot}}$$

Since the resistance are in series, it follows that

$$R_{tot} = \sum R_t = \frac{1}{h_1 A} + \frac{L}{kA} + \frac{1}{h_2 A}$$

Composite walls:

Thermal Resistances in Series:

Consider three blocks, A, B and C, as shown. They are insulated on top, bottom, front and back. Since the energy will flow first through block A and then through blocks B and C, we say that these blocks are thermally in a series arrangement.

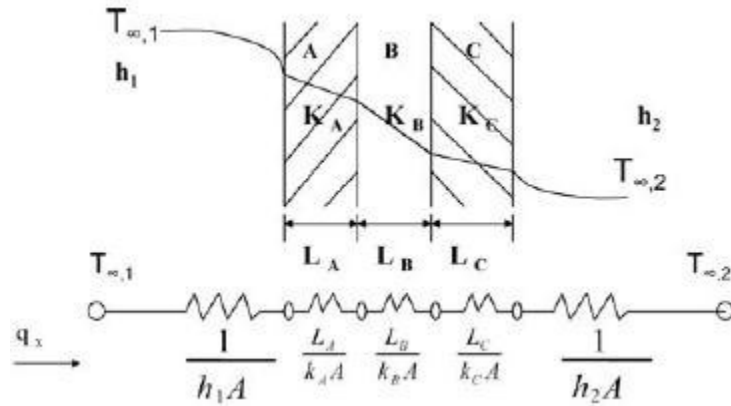

The steady state heat flow rate through the walls is given by:

$$q_x = \frac{T_{\infty,1} - T_{\infty,2}}{\sum R_t} = \frac{T_{\infty,1} - T_{\infty,2}}{\frac{1}{h_1 A} + \frac{L_A}{k_A A} + \frac{L_B}{k_B A} + \frac{L_C}{k_C A} + \frac{1}{h_2 A}} = UA\Delta T$$

where $U = \frac{1}{R_{tot} A}$ is the overall heat transfer coefficient. In the above case, U is expressed as

$$U = \frac{1}{\frac{1}{h_1} + \frac{L_A}{k_A} + \frac{L_B}{k_B} + \frac{L_C}{k_C} + \frac{1}{h_2}}$$

Series-parallel arrangement:

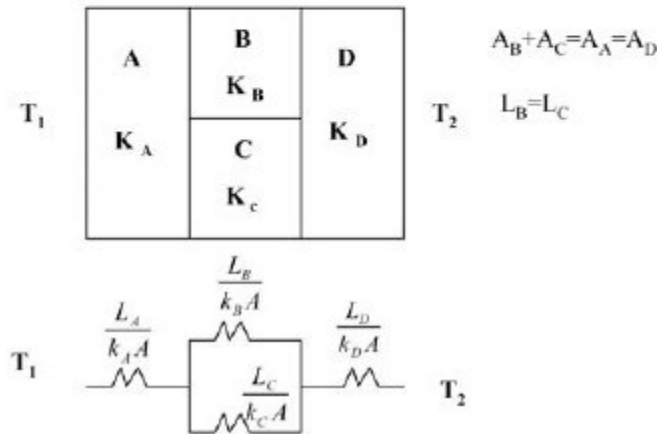

The following assumptions are made with regard to the above thermal resistance model:

- 1) Face between B and C is insulated.
- 2) Uniform temperature at any face normal to X.

1-D radial conduction through a cylinder:

One frequently encountered problem is that of heat flow through the walls of a pipe or through the insulation placed around a pipe. Consider the cylinder shown. The pipe is either insulated on the ends or is of sufficient length, L , that heat losses through the ends are negligible. Assume no heat sources within the wall of the tube. If $T_1 > T_2$, heat will flow outward, radially, from the inside radius, R_1 , to the outside radius, R_2 . The process will be described by the Fourier Law.

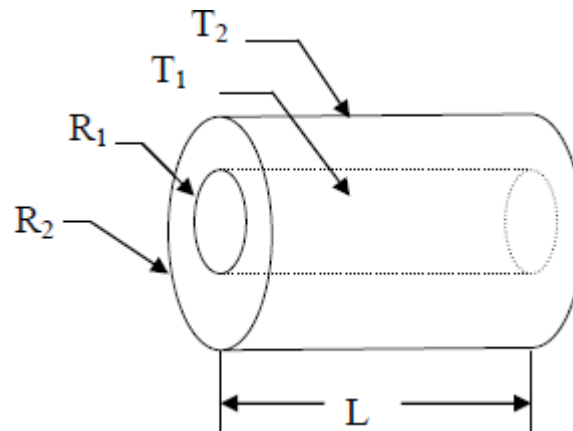

The differential equation governing heat diffusion is: $\frac{1}{r} \frac{d}{dr} \left(r \frac{dT}{dr} \right) = 0$

With constant k , the solution is

The heat flow rate across the wall is given by:

$$q_x = -kA \frac{dT}{dx} = \frac{kA}{L} (T_{s,1} - T_{s,2}) = \frac{T_{s,1} - T_{s,2}}{L/kA}$$

Hence, the thermal resistance in this case can be expressed as: $\frac{\ln \frac{r_1}{r_2}}{2\pi kL}$

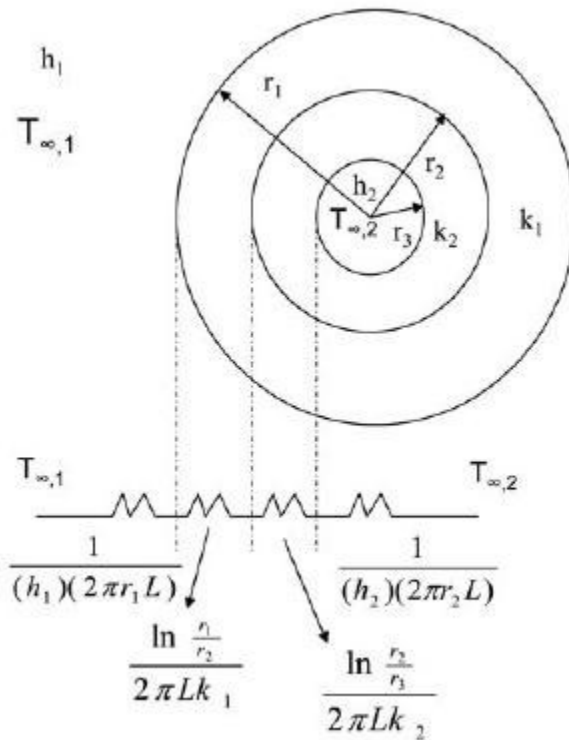
Composite cylindrical walls:

$$q_r = \frac{T_{\infty,2} - T_{\infty,1}}{\sum R_t}$$

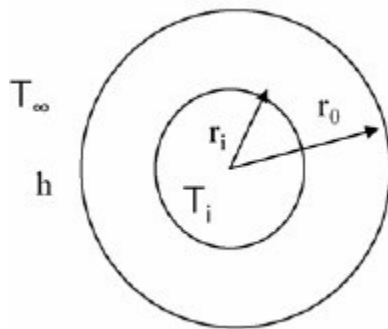
Critical Insulation Thickness:

$$R_{tot} = \frac{\ln\left(\frac{r_o}{r_i}\right)}{2\pi k L} + \frac{1}{(2\pi r_o L)h}$$

Insulation thickness : $r_o - r_i$

Objective: decrease q , increase R_{Total}

Vary r_o ; as r_o increases, first term increases, second term decreases.

This is a maximum – minimum problem. The point of extreme can be found by setting

$$\frac{dR_{tot}}{dr_0} = 0$$

$$\text{or, } \frac{1}{2\pi k r_0 L} - \frac{1}{2\pi h L r_0^2} = 0$$

$$\text{or, } r_0 = \frac{k}{h}$$

In order to determine if it is a maxima or a minima, we make the second derivative zero:

$$\frac{d^2 R_{tot}}{dr_0^2} = 0 \quad \text{at} \quad r_0 = \frac{k}{h}$$

$$\frac{d^2 R_{tot}}{dr_0^2} = \frac{-1}{2\pi k r_0^2 L} + \frac{1}{\pi r_0^2 h L} \Bigg|_{r_0 = \frac{k}{h}} = \frac{h^2}{2\pi L k^3} > 0$$

Minimum q at $r_0 = (k/h) = r_{cr}$ (critical radius)

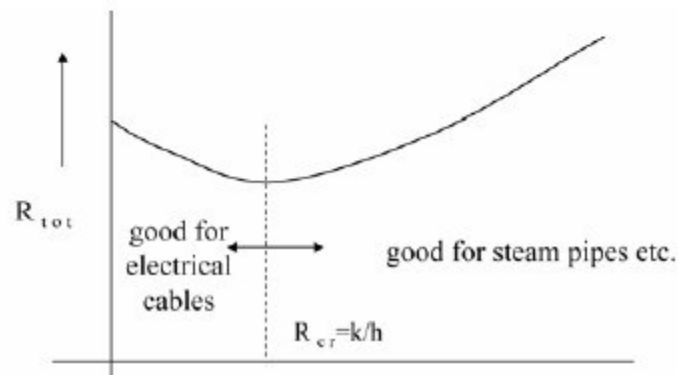

1-D radial conduction in a sphere:

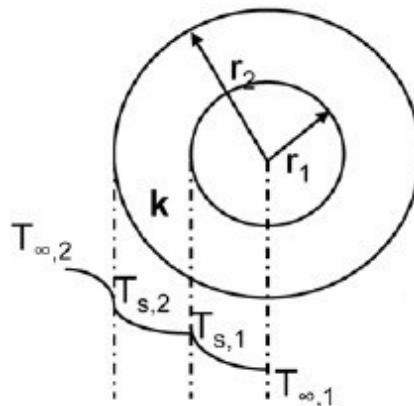

$$\frac{1}{r^2} \frac{d}{dr} \left(kr^2 \frac{dT}{dr} \right) = 0$$

$$\rightarrow T(r) = T_{s,1} - \{T_{s,1} - T_{s,2}\} \left[\frac{1-(r/r_1)}{1-(r_1/r_2)} \right]$$

$$\rightarrow q_r = -kA \frac{dT}{dr} = \frac{4\pi k(T_{s,1} - T_{s,2})}{(1/r_1 - 1/r_2)}$$

$$\rightarrow R_{t,cond} = \frac{1/r_1 - 1/r_2}{4\pi k}$$

Summary of Electrical Analogy:

System	Current	Resistance	Potential Difference
Electrical	I	R	ΔV
Cartesian Conduction	q	$\frac{L}{kA}$	ΔT
Cylindrical Conduction	q	$\frac{\ln r_2/r_1}{2\pi kL}$	ΔT
Conduction through sphere	q	$\frac{1/r_1 - 1/r_2}{4\pi k}$	ΔT
Convection	q	$\frac{1}{h \cdot A_s}$	ΔT

UNIT – 2 Fins & transient conduction

FINS: EXTENDED SURFACES

Heat transfer in extended surfaces of uniform cross-section without heat generation:

Convection: Heat transfer between a solid surface and a moving fluid is governed by the Newton's cooling law: $q = hA(T_s - T_\infty)$, where T_s is the surface temperature and T_∞ is the fluid temperature. Therefore, to increase the convective heat transfer, one can

- Increase the temperature difference ($T_s - T_\infty$) between the surface and the fluid.
- Increase the convection coefficient h . This can be accomplished by increasing the fluid flow over the surface since h is a function of the flow velocity and the higher the velocity, the higher the h .

Example: a cooling fan.

- Increase the contact surface area A . Example: a heat sink with fins.

Many times, when the first option is not in our control and the second option (i.e. increasing h) is already stretched to its limit, we are left with the only alternative of increasing the effective surface area by using

fins or extended surfaces. Fins are protrusions from the base surface into the cooling fluid, so that the extra surface of the protrusions is also in contact with the fluid. Most of you have encountered cooling fins on air-cooled engines (motorcycles, portable generators, etc.), electronic equipment (CPUs), automobile radiators, air conditioning equipment (condensers) and elsewhere.

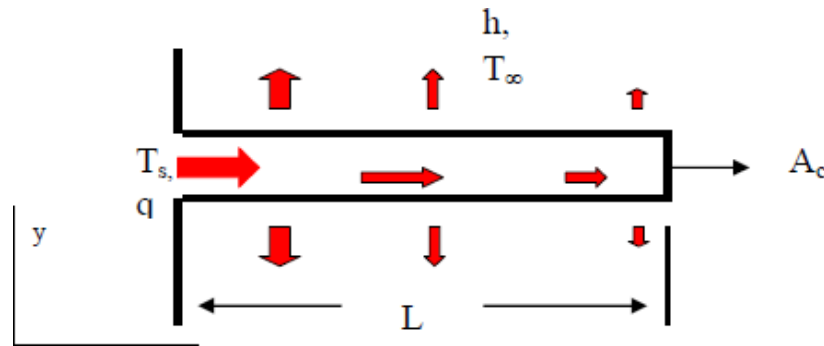

The fin is situated on the surface of a hot surface at T_s and surrounded by a coolant at temperature T_∞ , which cools with convective coefficient, h . The fin has a cross sectional area, A_c , (This is the area through which heat is conducted.) and an overall length, L .

Note that as energy is conducted down the length of the fin, some portion is lost, by convection, from the sides. Thus the heat flow varies along the length of the fin.

We further note that the arrows indicating the direction of heat flow point in both the x and y directions. This is an indication that this is truly a two- or three-dimensional heat flow, depending on the geometry of the fin. However, quite often, it is convenient to analyse a fin by examining an equivalent one-dimensional system. The equivalent system will involve the introduction of heat sinks (negative heat sources), which remove an amount of energy

Equivalent to what would be lost through the sides by convection.

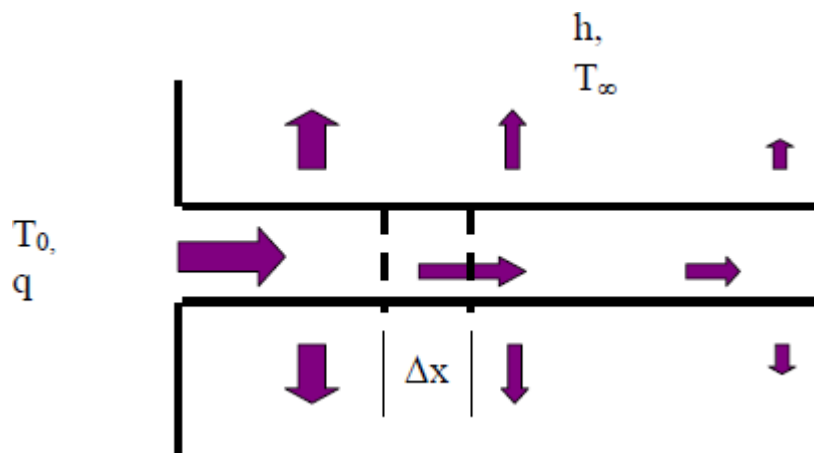

Across this segment the heat loss will be $h \cdot (P \cdot \Delta x) \cdot (T - T_\infty)$, where P is the perimeter around the fin. The equivalent heat sink would be $h \cdot P \cdot \Delta x$

Equating the heat source to the convective loss:

$$\ddot{q} = \frac{-h \cdot P \cdot (T - T_\infty)}{A_c}$$

Substitute this value into the General Conduction Equation as simplified for One-Dimension, Steady State Conduction with Sources:

$$\frac{d^2 T}{dx^2} - \frac{h \cdot P}{k \cdot A_c} \cdot (T - T_\infty) = 0$$

which is the equation for a fin with a constant cross sectional area. This is the Second Order Differential Equation that we will solve for each fin analysis. Prior to solving, a couple of simplifications should be noted. First, we see that h , P , k and A_c are all independent of x in the defined system (They may not be constant if a more general analysis is desired.). We replace this ratio with a constant. Let

$$m^2 = \frac{h \cdot P}{k \cdot A_c}$$

$$\frac{d^2 T}{dx^2} - m^2 \cdot (T - T_\infty) = 0$$

Next we notice that the equation is non-homogeneous (due to the T_∞ term). Recall that non homogeneous differential equations require both a general and a particular solution. We can make this equation homogeneous by introducing the temperature relative to the surroundings:

$$\theta \equiv T - T_\infty$$

Differentiating this equation we find:

$$\frac{d\theta}{dx} = \frac{dT}{dx} + 0$$

Differentiate a second time:

$$\frac{d^2 \theta}{dx^2} = \frac{d^2 T}{dx^2}$$

Substitute into the Fin Equation:

$$\frac{d^2\theta}{dx^2} - m^2 \cdot \theta = 0$$

This equation is a Second Order, Homogeneous Differential Equation.

Solution of the Fin Equation:

We apply a standard technique for solving a second order homogeneous linear differential equation.

Try $\theta = e^{\alpha x}$. Differentiate this expression twice:

$$\frac{d\theta}{dx} = \alpha \cdot e^{\alpha x}$$

$$\frac{d^2\theta}{dx^2} = \alpha^2 \cdot e^{\alpha x}$$

Substitute this trial solution into the differential equation:

$$\alpha^2 \cdot e^{\alpha x} - m^2 \cdot e^{\alpha x} = 0$$

Equation (13) provides the following relation:

$$\alpha = \pm m$$

We now have two solutions to the equation. The general solution to the above differential equation will be a linear combination of each of the independent solutions

Then:

$$\theta = A \cdot e^{m \cdot x} + B \cdot e^{-m \cdot x}$$

where A and B are arbitrary constants which need to be determined from the boundary conditions. Note that it is a 2nd order differential equation, and hence we need two boundary conditions to determine the two constants of integration.

An alternative solution can be obtained as follows: Note that the hyperbolic sin, sinh, the hyperbolic cosine, cosh, are defined as:

$$\sinh(m \cdot x) = \frac{e^{m \cdot x} - e^{-m \cdot x}}{2} \quad \cosh(m \cdot x) = \frac{e^{m \cdot x} + e^{-m \cdot x}}{2}$$

We may write:

$$C \cdot \cosh(m \cdot x) + D \cdot \sinh(m \cdot x) = C \cdot \frac{e^{m \cdot x} + e^{-m \cdot x}}{2} + D \cdot \frac{e^{m \cdot x} - e^{-m \cdot x}}{2} = \frac{C+D}{2} \cdot e^{m \cdot x} + \frac{C-D}{2} \cdot e^{-m \cdot x}$$

We see that if $(C+D)/2$ replaces A and $(C-D)/2$ replaces B then the two solutions are equivalent.

$$\theta = C \cdot \cosh(m \cdot x) + D \cdot \sinh(m \cdot x)$$

Generally the exponential solution is used for very long fins, the hyperbolic solutions for other cases.

Boundary Conditions:

Since the solution results in 2 constants of integration we require 2 boundary conditions. The first one is obvious, as one end of the fin will be attached to a hot surface and will come into thermal equilibrium with that surface.

Hence, at the fin base,

$$\theta(0) = T_0 - T_\infty \equiv \theta_0$$

The second boundary condition depends on the condition imposed at the other end of the fin.

There are various possibilities, as described below.

Very long fins:

For very long fins, the end located a long distance from the heat source will approach the temperature of the surroundings. Hence,

$$\theta(\infty) = 0$$

Substitute the second condition into the exponential solution of the fin equation:

$$\theta(\infty) = 0 = A \cdot e^{m \cdot \infty} + B \cdot e^{-m \cdot \infty}$$

The first exponential term is infinite and the second is equal to zero. The only way that this equation can be valid is if $A = 0$. Now apply the second boundary condition.

$$\theta(0) = \theta_0 = B \cdot e^{-m \cdot 0} \Rightarrow B = \theta_0$$

$$\theta(0) = \theta_0 = B \cdot e^{-m \cdot 0} \Rightarrow B = \theta_0$$

The general temperature profile for a very long fin is then:

$$\theta(x) = \theta_0 \cdot e^{-m \cdot x}$$

If we wish to find the heat flow through the fin, we may apply Fourier Law:

$$q = -k \cdot A_c \cdot \frac{dT}{dx} = -k \cdot A_c \cdot \frac{d\theta}{dx}$$

Differentiate the temperature profile:

$$\frac{d\theta}{dx} = -\theta_0 \cdot m \cdot e^{-m \cdot x}$$

So that:

$$q = k \cdot A_c \cdot \theta_0 \cdot \left[\frac{h \cdot P}{k \cdot A_c} \right]^{\frac{1}{2}} \cdot e^{-m \cdot x} = \sqrt{h \cdot P \cdot k \cdot A_c} \cdot e^{-m \cdot x} \cdot \theta_0 = M \theta_0 e^{-m \cdot x}$$

where $M = \sqrt{h P k A_c}$.

Often we wish to know the total heat flow through the fin, i.e. the heat flow entering at the base ($x=0$).

$$q = \sqrt{h \cdot P \cdot k \cdot A_c} \cdot \theta_0 = M \theta_0$$

The insulated tip fin:

Assume that the tip is insulated and hence there is no heat transfer:

$$\left. \frac{d\theta}{dx} \right|_{x=L} = 0$$

The solution to the fin equation is known to be:

$$\theta = C \cdot \cosh(m \cdot x) + D \cdot \sinh(m \cdot x)$$

Differentiate this expression.

$$\frac{d\theta}{dx} = C \cdot m \cdot \sinh(m \cdot x) + D \cdot m \cdot \cosh(m \cdot x)$$

Apply the first boundary condition at the base:

$$\theta(0) = \theta_0 = C \sinh(m \cdot 0) + D \cosh(m \cdot 0)$$

So that $D = \theta_0$. Now apply the second boundary condition at the tip to find the value of C:

$$\frac{d\theta}{dx}(L) = 0 = Cm \sinh(m \cdot L) + \theta_0 m \cosh(m \cdot L)$$

This requires that

$$C = -\theta_0 \frac{\cosh(mL)}{\sinh(mL)}$$

We may find the heat flow at any value of x by differentiating the temperature profile and substituting it into the Fourier Law:

$$q = -k \cdot A_c \cdot \frac{dT}{dx} = -k \cdot A_c \cdot \frac{d\theta}{dx}$$

So that the energy flowing through the base of the fin is:

$$q = \sqrt{hPkA_c} \theta_0 \tanh(mL) = M\theta_0 \tanh(mL)$$

If we compare this result with that for the very long fin, we see that the primary difference in form is in the hyperbolic tangent term. That term, which always results in a number equal to or less than one, represents the reduced heat loss due to the shortening of the fin.

Case	Tip Condition	Temp. Distribution	Fin heat transfer
A	Convection heat transfer: $h\theta(L) = -k(d\theta/dx)_{x=L}$	$\frac{\cosh m(L-x) + (h/mk) \sinh m(L-x)}{\cosh mL + (h/mk) \sinh mL}$	$M\theta_0 \frac{\sinh mL + (h/mk) \cosh mL}{\cosh mL + (h/mk) \sinh mL}$
B	Adiabatic $(d\theta/dx)_{x=L} = 0$	$\frac{\cosh m(L-x)}{\cosh mL}$	$M\theta_0 \tanh mL$
C	Given temperature: $\theta(L) = \theta_L$	$\frac{(\theta_L/\theta_b) \sinh m(L-x) + \sinh m(L-x)}{\sinh mL}$	$M\theta_0 \frac{(\cosh mL - \theta_L/\theta_b)}{\sinh mL}$
D	Infinitely long fin $\theta(L) = 0$	e^{-mx}	$M\theta_0$

Fin Effectiveness:

How effective a fin can enhance heat transfer is characterized by the fin effectiveness, ϵ_f , which is as the ratio of fin heat transfer and the heat transfer without the fin. For an adiabatic fin:

$$\epsilon_f = \frac{q_f}{q} = \frac{q_f}{hA_c(T_b - T_\infty)} = \frac{\sqrt{hPkA_c} \tanh(mL)}{hA_c} = \sqrt{\frac{kP}{hA_c}} \tanh(mL)$$

If the fin is long enough, $mL > 2$, $\tanh(mL) \rightarrow 1$, and hence it can be considered as infinite fin (case D in table). Hence, for long fins,

$$\epsilon_f \rightarrow \sqrt{\frac{kP}{hA_c}} = \sqrt{\left(\frac{k}{h}\right) \frac{P}{A_c}}$$

Fin Efficiency:

The fin efficiency is defined as the ratio of the energy transferred through a real fin to that transferred through an ideal fin. An ideal fin is thought to be one made of a perfect or infinite conductor material. A perfect conductor has an infinite thermal conductivity so that the entire fin is at the base material temperature.

$$\eta = \frac{q_{real}}{q_{ideal}} = \frac{\sqrt{h \cdot P \cdot k \cdot A_c} \cdot \theta_L \cdot \tanh(m \cdot L)}{h \cdot (P \cdot L) \cdot \theta_L}$$

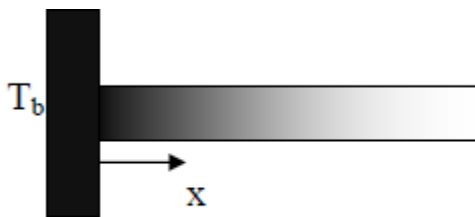
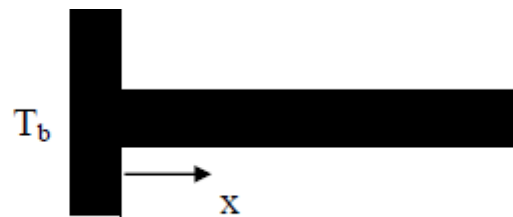
*Real situation**Ideal situation*

$$\eta = \sqrt{\frac{k \cdot A_c}{h \cdot P}} \frac{\theta_L \cdot \tanh(m \cdot L)}{L \cdot \theta_L} = \frac{\tanh(m \cdot L)}{m \cdot L}$$

TRANSIENT CONDUCTION

Introduction:

To this point, we have considered conductive heat transfer problems in which the temperatures are independent of time. In many applications, however, the temperatures are varying with time, and we require the understanding of the complete time history of the temperature variation. For example, in metallurgy, the heat treating process can be controlled to directly affect the characteristics of the processed materials. Annealing (slow cool) can soften metals and improve ductility. On the other hand, quenching (rapid cool) can harden the strain boundary and increase strength. In order to characterize this transient behavior, the full unsteady equation is needed:

$$\frac{1}{a} \cdot \frac{\partial T}{\partial \tau} = \frac{\partial^2 T}{\partial x^2} + \frac{\partial^2 T}{\partial y^2} + \frac{\partial^2 T}{\partial z^2} + \frac{q}{k}$$

Where $\alpha = \frac{k}{\rho C_p}$ is the thermal diffusivity without any heat generation and considering spatial variation of

temperature only in x-direction, the above equation reduces to:

$$\frac{1}{a} \cdot \frac{\partial T}{\partial \tau} = \frac{\partial^2 T}{\partial x^2}$$

For the solution of equation (5.2), we need two boundary conditions in x-direction and one initial condition. Boundary conditions, as the name implies, are frequently specified along the physical boundary of an object; they can, however, also be internal – e.g. a known temperature gradient at an internal line of symmetry.

Biot and Fourier numbers:

In some transient problems, the internal temperature gradients in the body may be quite small and insignificant. Yet the temperature at a given location, or the average temperature of the object, may be changing quite rapidly with time. From eq. (5.1) we can note that such could be the case for large thermal diffusivity α .

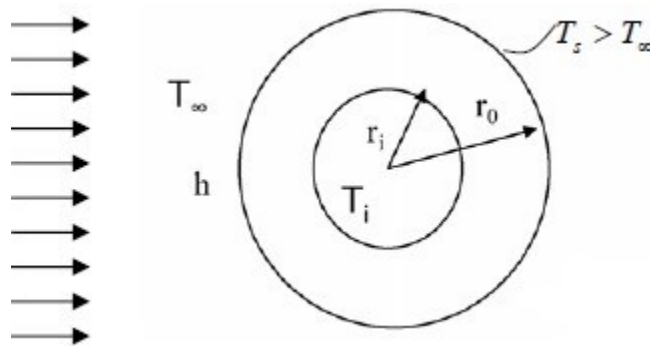

For very large r_i , the heat transfer rate by conduction through the cylinder wall is approximately

$$q \approx -k(2\pi r_o l) \left(\frac{T_s - T_i}{r_o - r_i} \right) = k(2\pi r_o l) \left(\frac{T_i - T_s}{L} \right)$$

where l is the length of the cylinder and L is the material thickness. The rate of heat transfer away from the outer surface by convection is

$$q = \bar{h}(2\pi r_o l)(T_s - T_\infty)$$

where \bar{h} is the average heat transfer coefficient for convection from the entire surface. Equating (5.3) and (5.4) gives

$$\frac{T_i - T_s}{T_s - T_\infty} = \frac{\bar{h}L}{k} = \text{Biot number}$$

The Biot number is dimensionless, and it can be thought of as the ratio

$$\mathbf{Bi} = \frac{\text{resistance to internal heat flow}}{\text{resistance to external heat flow}}$$

Whenever the Biot number is small, the internal temperature gradients are also small and a transient problem can be treated by the “lumped thermal capacity” approach. The lumped capacity assumption implies that the object for analysis is considered to have a single mass averaged temperature.

In the derivation shown above, the significant object dimension was the conduction path length $L = r_o - r_i$. In general, a characteristic length scale may be obtained by dividing the volume of the solid by its surface area:

$$L = \frac{V}{A_s}$$

Using this method to determine the characteristic length scale, the corresponding Biot number may be evaluated for objects of any shape, for example a plate, a cylinder, or a sphere. As a thumb rule, if the Biot number turns out to be less than 0.1, lumped capacity assumption is applied.

In this context, a *dimensionless time*, known as the **Fourier number**, can be obtained by multiplying the dimensional time by the thermal diffusivity and dividing by the square of the characteristic length:

$$\text{dimensionless time} = \frac{\alpha t}{L^2} = \text{Fo}$$

Lumped thermal capacity analysis:

The simplest situation in an unsteady heat transfer process is to use the lumped capacity assumption, wherein we neglect the temperature distribution inside the solid and only deal with the heat transfer between the solid and the ambient fluids. In other words, we are assuming that the temperature inside the solid is constant and is equal to the surface temperature.

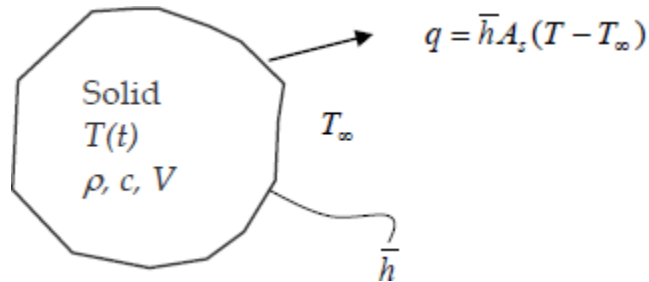

The solid object shown in figure 5.2 is a metal piece which is being cooled in air after hot forming. Thermal energy is leaving the object from all elements of the surface, and this is shown for simplicity by a single arrow. The first law of thermodynamics applied to this problem is

$$\left(\begin{array}{l} \text{heat out of object} \\ \text{during time } dt \end{array} \right) = \left(\begin{array}{l} \text{decrease of internal thermal} \\ \text{energy of object during time } dt \end{array} \right)$$

Now, if Biot number is small and temperature of the object can be considered to be uniform, this equation can be written as

$$\bar{h}A_s [T(t) - T_\infty] dt = -\rho c V dT$$

$$\frac{dT}{(T - T_\infty)} = -\frac{\bar{h}A_s}{\rho c V} dt$$

Integrating and applying the initial condition $T(0) = T_i$,

$$\ln \frac{T(t) - T_\infty}{T_i - T_\infty} = -\frac{\bar{h}A_s}{\rho c V} t$$

Taking the exponents of both sides and rearranging,

$$\frac{T(t) - T_{\infty}}{T_i - T_{\infty}} = e^{-bt}$$

where

$$b = \frac{\bar{h}A_s}{\rho c V} \quad (1/s)$$

Rate of convection heat transfer at any given time t :

$$\dot{Q}(t) = h\bar{A}_s [T(t) - T_{\infty}]$$

Total amount of heat transfer between the body and the surrounding from $t=0$ to t :

$$Q = mc [T(t) - T_i]$$

Maximum heat transfer (limit reached when body temperature equals that of the surrounding):

$$Q = mc [T_{\infty} - T_i]$$

Use of Transient temperature charts (Heisler's charts):

The Plane Wall:

In Sections 5.5 and 5.6, one-term approximations have been developed for transient, one-dimensional conduction in a plane wall (with symmetrical convection conditions) and radial systems (long cylinder and sphere). The results apply for $Fo \geq 0.2$ and can conveniently be represented in graphical forms that illustrate the functional dependence of the transient temperature distribution on the Biot and Fourier numbers.

Results for the plane wall (Figure 5.6a) are presented in Figures 5S.1 through 5S.3. Figure 5S.1 may be used to obtain the *midplane* temperature of the wall, $T(0, t) = T_o(t)$, at any time during the transient process. If T_o is known for particular values of Fo and Bi , Figure 5S.2 may be used to determine the corresponding temperature at any location *off the midplane*. Hence Figure 5S.2 must be used in conjunction with Figure 5S.1. For example, if one wishes to determine the surface temperature ($x^* = 1$) at some time t , Figure 5S.1 would first be used to determine T_o at t . Figure 5S.2 would then be used to determine the surface temperature from knowledge of T_o . The

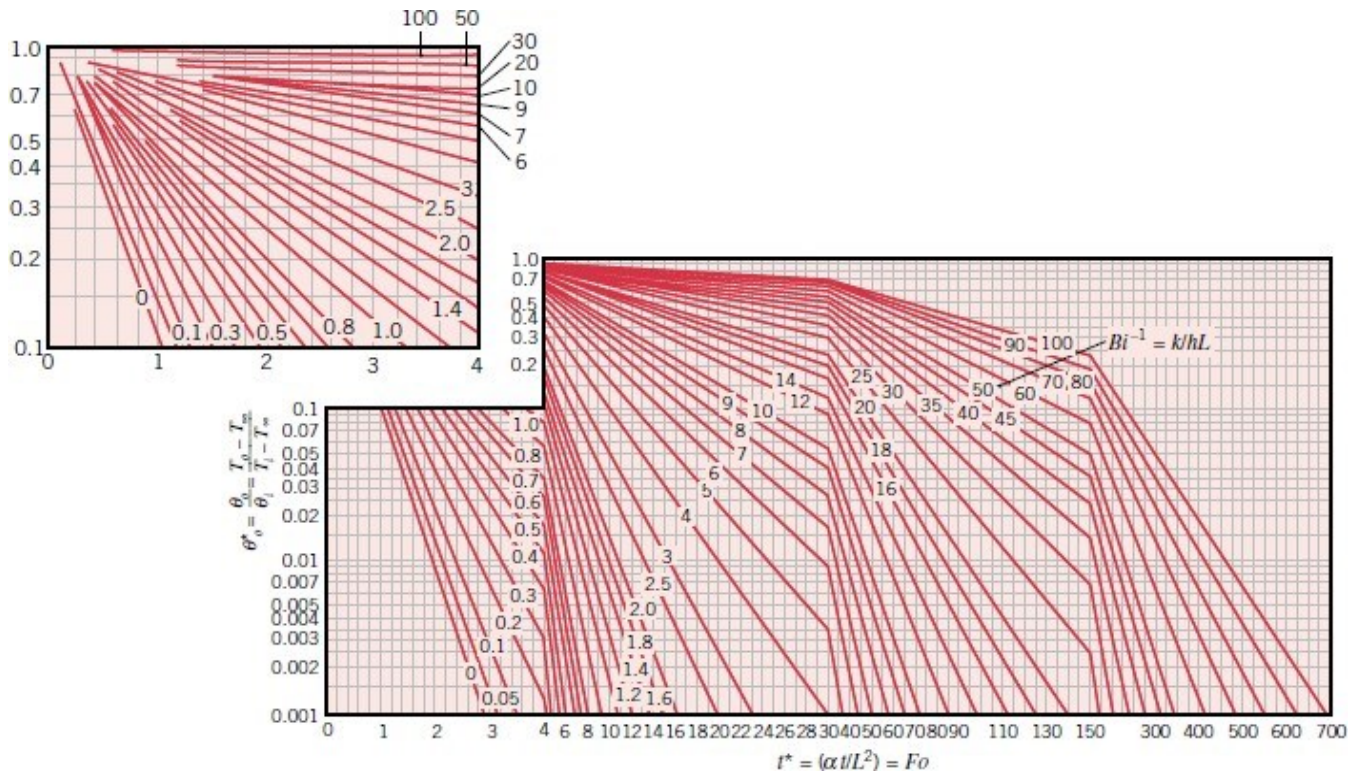

FIGURE 5S.1 Midplane temperature as a function of time for a plane wall of thickness $2L$.

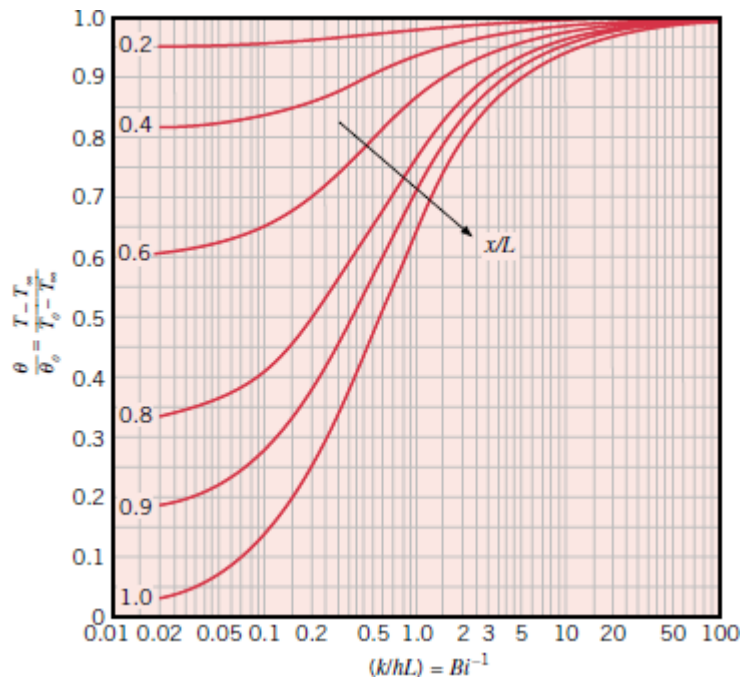

FIGURE 5S.2 Temperature distribution in a plane wall of thickness $2L$

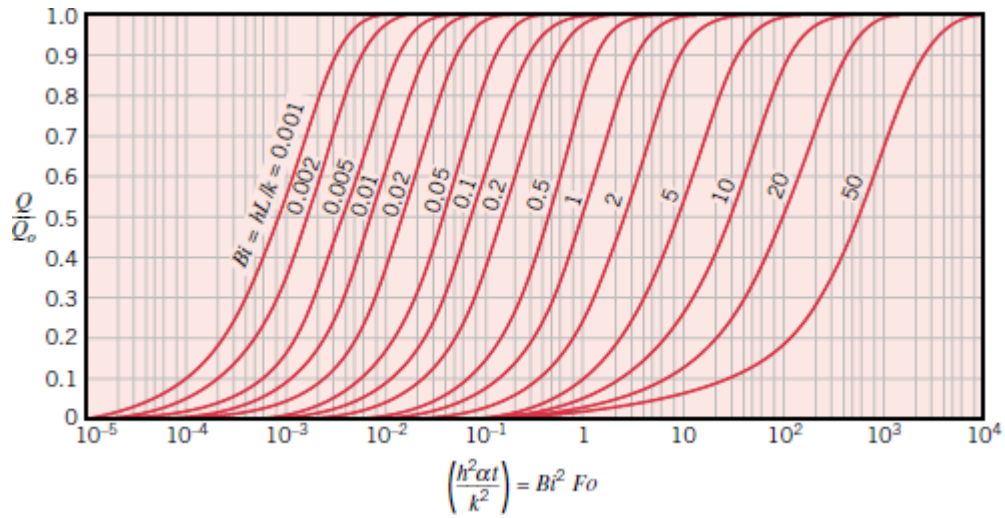

FIGURE 5S.3 Internal energy change as a function of time for a plane wall of thickness 2L

The cylinder:

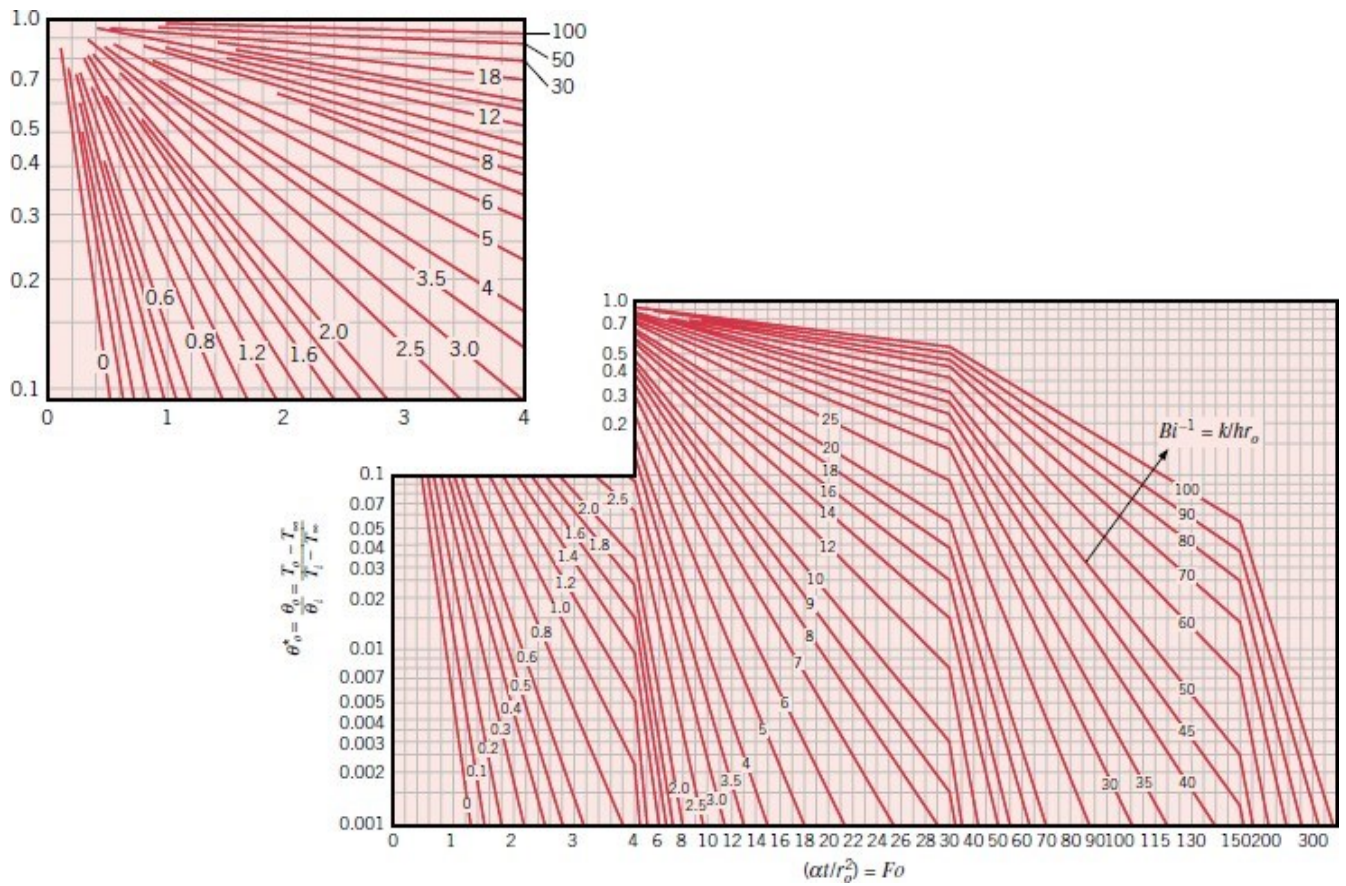

FIGURE 5S.4 Centerline temperature as a function of time for an infinite cylinder of radius r_o

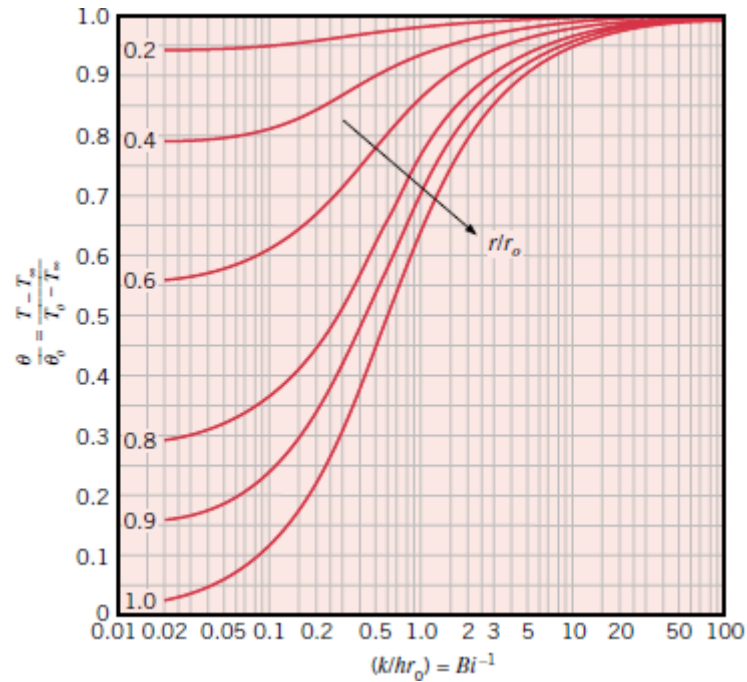

FIGURE 5S.5 Temperature distribution in an infinite cylinder of radius r_0

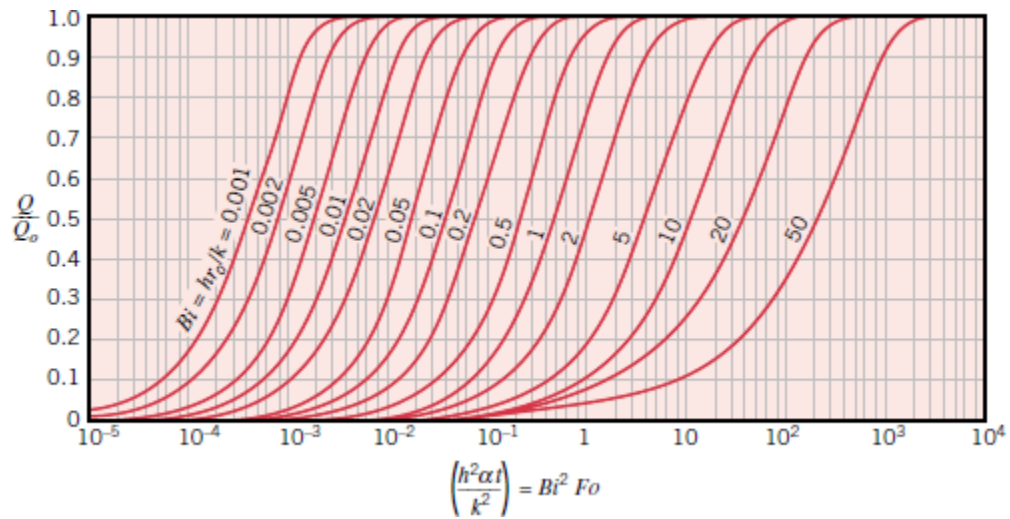

FIGURE 5S.6 Internal energy change as a function of time for an infinite cylinder of radius r_0

For sphere:

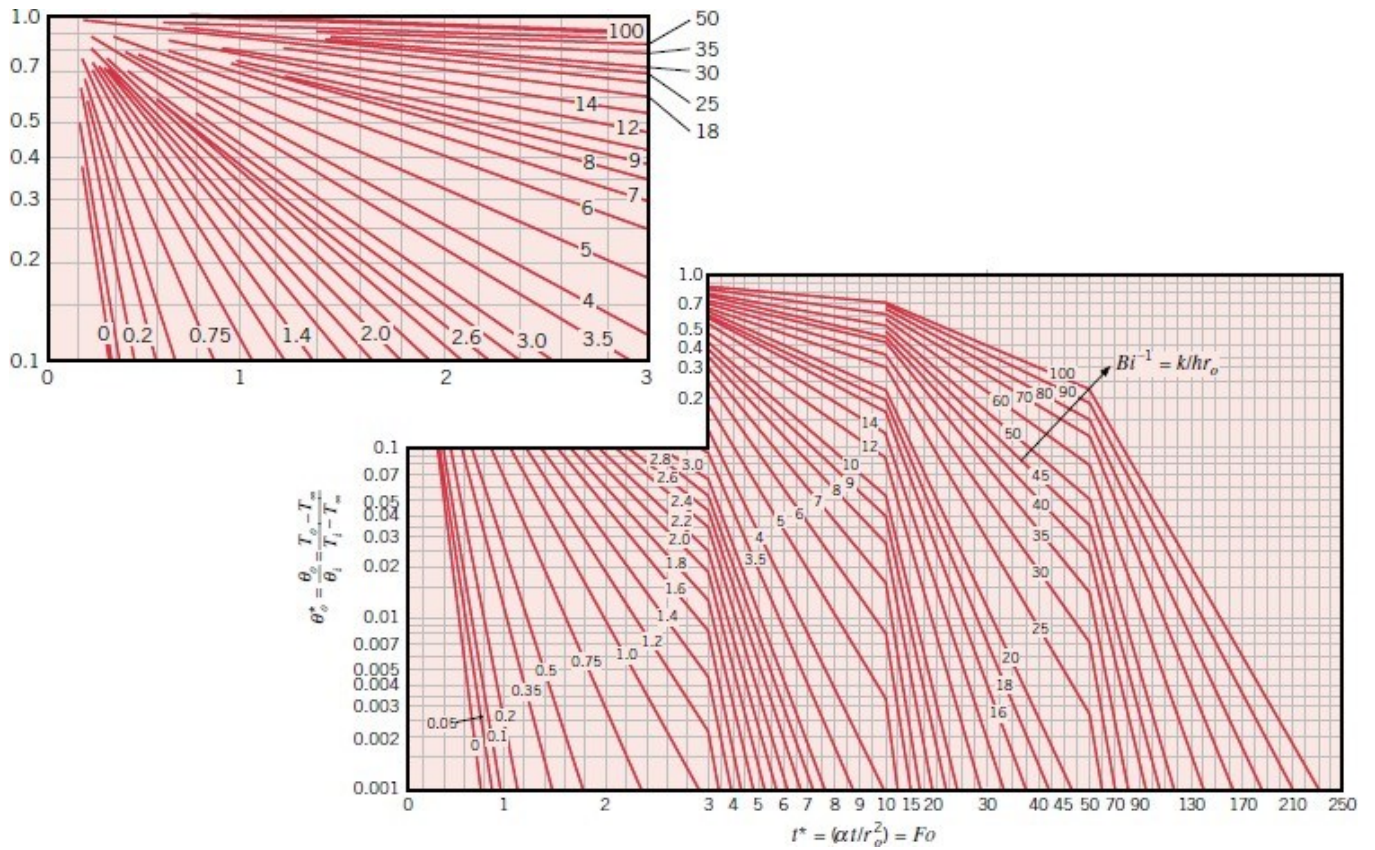

FIGURE 5S.7 Center temperature as a function of time in a sphere of radius r_0

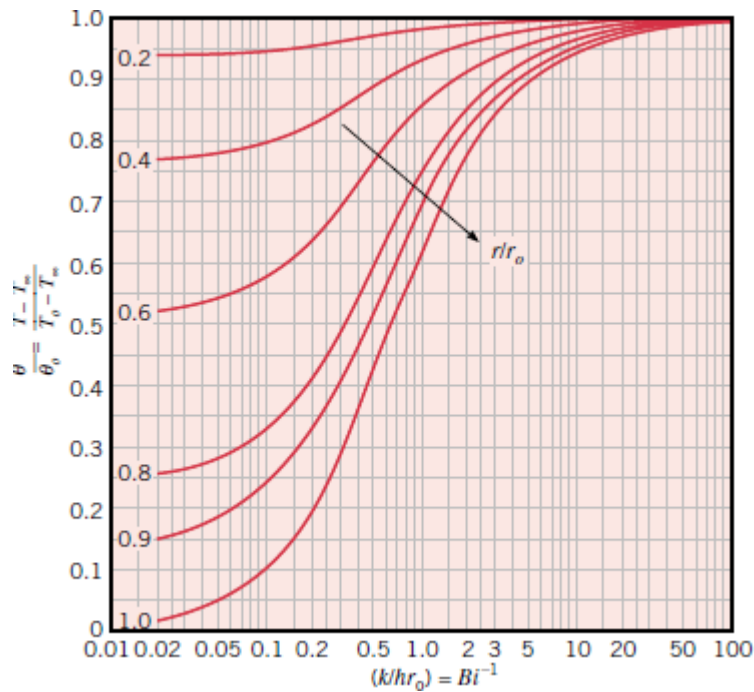

FIGURE 5S.8 Temperature distribution in a sphere of radius r_0

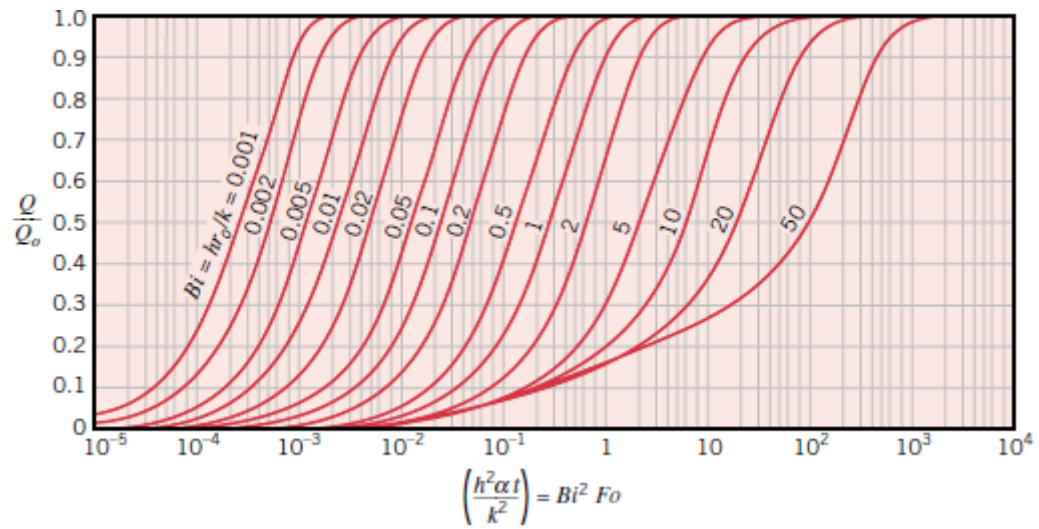

FIGURE 5S.9 Internal energy change as a function of time for a sphere of radius r_0

UNIT – 3 Concepts and basic relations in boundary layers:

Introduction:

Convection is the mode of heat transfer between a surface and a fluid moving over it. The energy transfer in convection is predominately due to the bulk motion of the fluid particles; through the molecular conduction within the fluid itself also contributes to some extent. If this motion is mainly due to the density variations associated with temperature gradients within the fluid, the mode of heat transfer is said to be due to *free or natural convection*. On the other hand if this fluid motion is principally produced by some superimposed velocity field like fan or blower, the energy transport is said to be due to *forced convection*.

Convection Boundary Layers:

Velocity Boundary Layer: Consider the flow of fluid over a flat plate as shown in the figure. The fluid approaches the plate in x direction with uniform velocity u_{∞} . The fluid particles in the fluid layer adjacent to the surface get zero velocity. This motionless layer acts to retract the motion of particles in the adjoining fluid layer as a result of friction between the particles of these two adjoining fluid layers at two different velocities. This fluid layer then acts to restart the motion of particles of next fluid layer and so on, until a distance $y = \delta$ from surface reaches, where these effects become negligible and the fluid velocity u reaches the free stream velocity u_{∞} . as a result of frictional effects between the fluid layers, the local fluid velocity u will vary from $x = 0, y = 0$ to $y = \delta$.

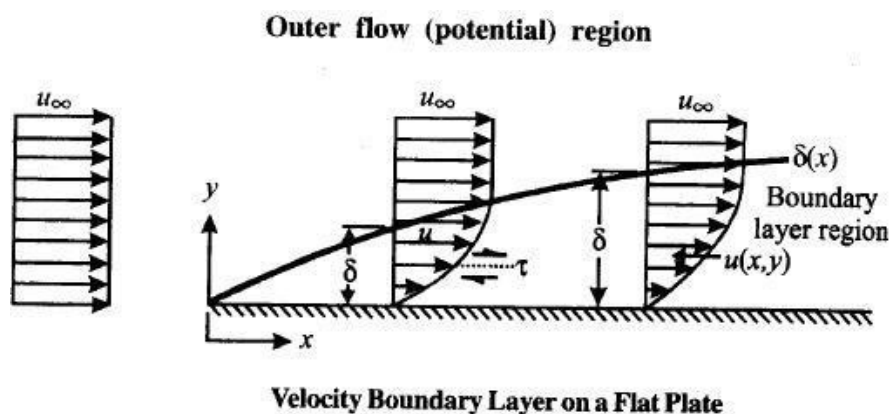

The region of the flow over the surface bounded by δ in which the effects of viscous shearing forces caused by fluid viscosity are observed, is called velocity boundary layer or hydro dynamic boundary layer. The thickness of boundary layer δ is generally defined as a distance from the surface at which local velocity $u = 0.99$ of free stream velocity u_{∞} . The retardation of fluid motion in the boundary layer is due to the shear stresses acting in opposite direction with increasing the distance y from the surface shear stress decreases, the local velocity u increases until

approaches u_∞ . With increasing the distance from the leading edge, the effect of viscosity penetrates further into the free stream and boundary layer thickness grows.

Thermal boundary Layer: If the fluid flowing on a surface has a different temperature than the surface, the thermal boundary layer developed is similar to the velocity boundary layer. Consider a fluid at a temperature T_∞ flows over a surface at a constant temperature T_s . The fluid particles in adjacent layer to the plate get the same temperature that of surface. The particles exchange heat energy with particles in adjoining fluid layers and so on. As a result, the temperature gradients are developed in the fluid layers and a temperature profile is developed in the fluid flow, which ranges from T_s at the surface to fluid temperature T_∞ sufficiently far from the surface in y direction.

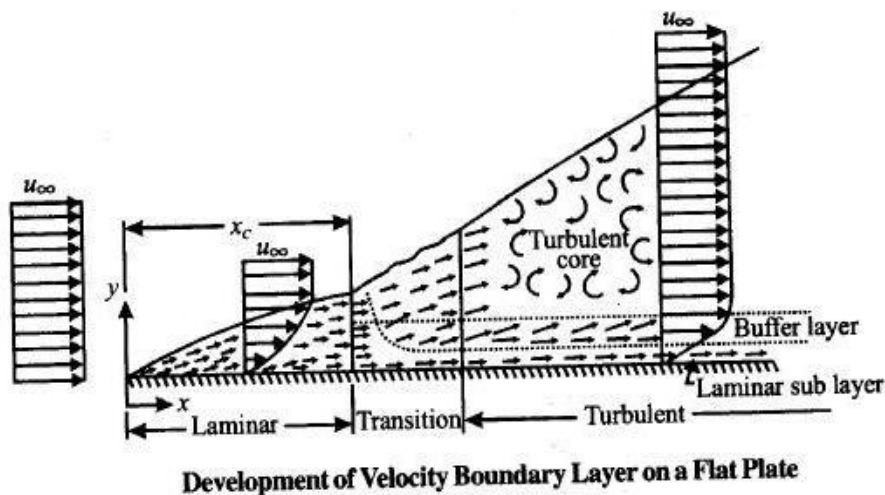

The flow region over the surface in which the temperature variation in the direction, normal to surface is [REDACTED] at any location along the length of flow is defined as a distance y from the surface at which the temperature difference $(T - T_s)$ equal 0.99 of $(T_\infty - T_s)$. With increasing the distance from leading edge the effect of heat transfer penetrates further into the free stream and the thermal boundary layer grows as shown in the figure. The convection heat transfer rate anywhere along the surface is directly related to the temperature gradient at that location. Therefore, the shape of the temperature profile in the thermal boundary layer leads to the local convection heat transfer between surface and flowing fluid.

Development of velocity boundary layer on a flat plate:

It is most essential to distinguish between laminar and turbulent boundary layers. Initially, the boundary layer development is laminar as shown in figure for the flow over a flat plate. Depending upon the flow field and fluid properties, at some critical distance from the leading edge small disturbances in the flow begin to get

amplified, a transition process takes place and the flow becomes turbulent. In laminar boundary layer, the fluid motion is highly ordered whereas the motion in the turbulent boundary layer is highly irregular with the fluid moving to and from in all directions. Due to fluid mixing resulting from these macroscopic motions, the turbulent boundary layer is thicker and the velocity profile in turbulent boundary layer is flatter than that in laminar flow.

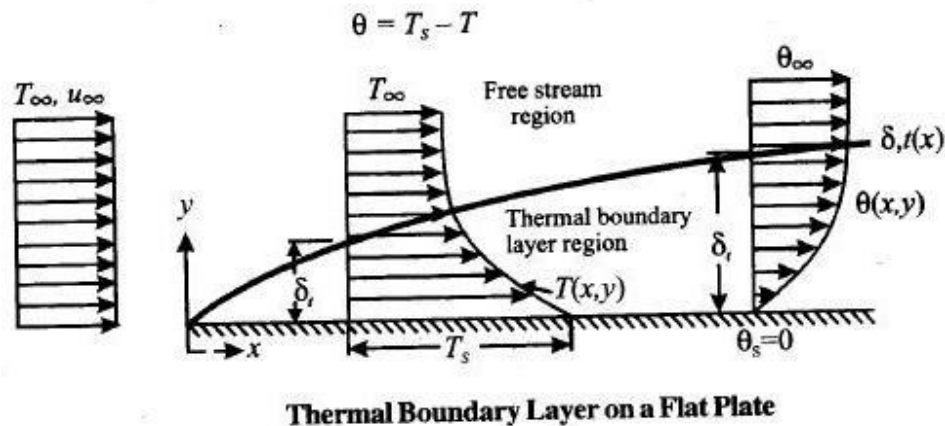

The critical distance x_c beyond which the flow cannot retain its laminar character is usually specified in term of critical Reynolds number Re_c . Depending upon surface and turbulence level of free stream the critical Reynolds number varies between 10^5 and 3×10^6 . In the turbulent boundary layer, as seen three distinct regimes exist. A laminar sub-layer, existing next to the wall, has a nearly linear velocity profile. The convective transport in this layer is mainly molecular. In the buffer layer adjacent to the sub-layer, the turbulent mixing and diffusion effects are comparable. Then there is the turbulent core with large scale turbulence.

Application of dimensional analysis for free convection:

Dimensional analysis is a mathematical method which makes use of the study of the dimensions for solving several engineering problems. This method can be applied to all types of fluid resistances, heat flow problems in fluid mechanics and thermodynamics.

Let us assume that heat transfer coefficient 'h' in fully developed forced convection in tube is function of following variables;

$$h = f(D, V, k, \rho, \mu, c_p) \text{ or } \dots\dots\dots(1)$$

$$f_1(h, D, V, \rho, k, \mu, c_p) \text{ } \dots\dots\dots(2)$$

Nusselt Number (Nu).

It is defined as the ratio of the heat flow by convection process under a unit temperature gradient to the heat flow rate by conduction under a unit temperature gradient through a stationary thickness (L).

$$\text{Nusselt Number}(Nu) = \frac{q_{con}}{q_{cond}}$$

Grashof number (Gr).

It is defined as the ratio of product of inertia force and buoyancy force to the square of viscous force.

$$\text{Grashof number } (Gr) = \frac{\text{Inertia force} \times \text{Buoyancy force}}{\text{Viscus force}^2}$$

Prandtl number (Pr).

It is the ratio of the momentum diffusivity to the thermal diffusivity.

$$\text{Prandtl number } (Pr) = \frac{\text{Momentum diffusivit}}{\text{Thermal diffusivit}}$$

FORCED CONVECTION

Applications of dimensional analysis for forced convection:

Dimensional analysis is a mathematical method which makes use of the study of the dimensions for solving several engineering problems. This method can be applied to all types of fluid resistances, heat flow problems in fluid mechanics and thermodynamics.

Let us assume that heat transfer coefficient 'h' in fully developed forced convection in tube is function of following variables;

$$h = f(D, V, k, \rho, \mu, c_p) \text{ or}$$

$$f_1(h, D, V, \rho, k, \mu, c_p)$$

Sr. No.	Variables	Symbols	Dimensions
01	Heat transfer coefficient	h	$MT^{-3} \theta^{-1}$
02	Fluid density	ρ	ML^{-3}
03	Tube diameter	D	L
04	Fluid velocity	V	LT^{-1}
05	Fluid viscosity	μ	$ML^{-1} T^{-1}$
06	Specific heat	c_p	$L^2 T^{-2} \theta^{-1}$
07	Thermal conductivity	k	$MLT^{-3} \theta^{-1}$

Total no. of variables = $n=7$

Fundamental dimensions in problem = $m=4$ (M, L, T, θ)

No. of dimensionless π -Term = $n-m = 3$

Equation (2) can be written as;

$$f_1(\pi_1, \pi_2, \pi_3) = 0$$

Choosing h, D, V, ρ as group of repeating variables with unknown exponents.

Therefore,

$$\pi_1 = h^{a_1} \cdot \rho^{b_1} \cdot D^{c_1} \cdot V^{d_1} \cdot \mu$$

$$\pi_2 = h^{a_2} \cdot \rho^{b_2} \cdot D^{c_2} \cdot V^{d_2} \cdot C_P$$

$$\pi_3 = h^{a_3} \cdot \rho^{b_3} \cdot D^{c_3} \cdot V^{d_3} \cdot K$$

π_1 -Term:

$$ML^{-1}T^{-1} = (ML^{-3}\theta^{-1})^{a_1} \cdot (ML^{-3})^{b_1} \cdot (L)^{c_1} \cdot (LT^{-1})^{d_1} \cdot (ML^{-1}T^{-1})$$

Equating exponents of M, L, T, θ respectively, we get;

$$a_1 = 0, b_1 = -1, c_1 = -1, d_1 = -1$$

$$\pi_1 = h^{a_1} \cdot \rho^{b_1} \cdot D^{c_1} \cdot V^{d_1} \cdot \mu$$

$$\pi_1 = \frac{\mu}{D \cdot V \cdot \rho}$$

Similarly for π_2 and π_3 Term

π_2 -Term:

$$\pi_2 = h^{-1} \cdot \rho \cdot V \cdot C_P$$

$$\pi_2 = \frac{\rho \cdot V \cdot C_P}{h}$$

Since dimensions of h and k/D are same;

$$\pi_2 = \rho \cdot V \cdot C_P \cdot \frac{D}{K}$$

π_3 -Term:

$$\pi_3 = h^{-1} \cdot D^{-1} \cdot K$$

$$\pi_3 = \frac{K}{h \cdot D}$$

According to π theorem: $\pi_3 = \phi(\pi_1, \pi_2)$

$$\frac{K}{h \cdot D} = \text{constant} \left(\frac{\mu}{D \cdot V \cdot \rho} \right)^{m'} (\rho \cdot V \cdot C_P \cdot D / K)^{n'}$$

where m' and n' are constants.

If $m' > n'$, then

$$\frac{K}{h \cdot D} = \text{constant} \left(\frac{\mu}{D \cdot V \cdot \rho} \right)^{n'} (\rho \cdot V \cdot C_P \cdot D / K)^{m'-n'} \left(\frac{\mu}{D \cdot V \cdot \rho} \right)^{m'-n'}$$

$$\frac{K}{h \cdot D} = \text{constant} \left(\frac{\mu}{D \cdot V \cdot \rho} \right)^{m'-n'} \left(\frac{\mu \cdot C_P}{K} \right)^{n'}$$

OR

$$\frac{h \cdot D}{K} = \text{constant} \left(\frac{D \cdot V \cdot \rho}{\mu} \right)^m \left(\frac{\mu \cdot C_P}{K} \right)^n$$

OR

$$Nu = \text{constant} (Re)^m (Pr)^n$$

Nusselt Number (Nu).

It is defined as the ratio of the heat flow by convection process under a unit temperature gradient to the heat flow rate by conduction under a unit temperature gradient through a stationary thickness (L).

$$\text{Nusselt Number}(Nu) = \frac{q_{con}}{q_{cond}}$$

Reynolds number (Re).

It is defined as the ratio of inertia force to viscous force.

$$\text{Reynolds number}(Re) = \frac{\text{Inertia force}}{\text{Viscusforce}}$$

Prandtl number (Pr).

It is the ratio of the momentum diffusivity to the thermal diffusivity.

$$\text{Prandtl number (Pr)} = \frac{\text{Momentum diffusivity}}{\text{Thermal diffusivity}}$$

HEAT EXCHANGERS

The device used for exchange of heat between the two fluids that are at different temperatures, is called the *heat exchanger*. The heat exchangers are commonly used in wide range of applications, for example, in a car as radiator, where hot water from the engine is cooled by atmospheric air. In a refrigerator, the hot refrigerant from the compressor is cooled by natural convection into atmosphere by passing it through finned tubes. In a steam condenser, the latent heat of condensation is removed by circulating water through the tubes. The heat exchangers are also used in space heating and air-conditioning, waste heat recovery and chemical processing. Therefore, the different types of heat exchangers are needed for different applications.

The heat transfer in a heat exchanger usually involves convection on each side of fluids and conduction through the wall separating the two fluids. Thus for analysis of a heat exchanger, it is very convenient to work with an *overall heat transfer coefficient* U , that accounts for the contribution of all these effects on heat transfer. The rate of heat transfer between two fluids at any location in a heat exchanger depends on the magnitude of temperature difference at that location and this temperature difference varies along the length of heat exchanger. Therefore, it is also convenient to work with *logarithmic mean temperature difference* $LMTD$, which is an equivalent temperature difference between two fluids for entire length of heat exchanger.

Classification of heat exchangers:

Heat exchangers are designed in so many sizes, types, configurations and flow arrangements and used for so many purposes. These are classified according to heat transfer process, flow arrangement and type of construction.

According to Heat Transfer Process:

- (i) **Direct contact type.** In this type of heat exchanger, the two immiscible fluids at different temperatures are come in direct contact. For the heat exchange between two fluids, one fluid is sprayed through the other. Cooling towers, jet condensers, desuperheaters, open feed water heaters and -scrubbers are the best examples of such heat exchangers. It cannot be used for transferring heat

between two gases or between two miscible liquids. A direct contact type heat exchanger (cooling tower) is shown in Figure 6.1.

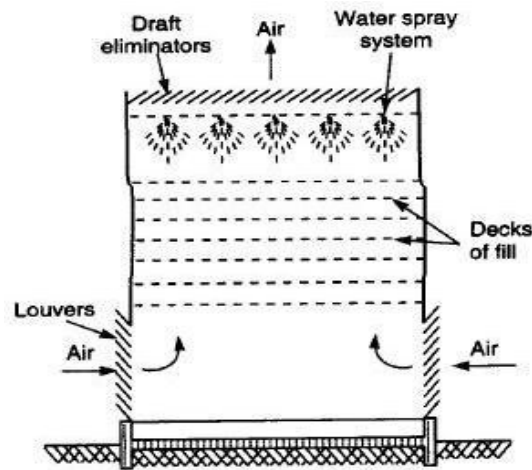

Figure 6.1: direct contact type heat exchanger (cooling tower)

(ii) Transfer type heat exchangers or recuperators:

In this type of heat exchanger, the cold and hot fluids flow simultaneously through the device and the heat is transferred through the wall separating them. These types of heat exchangers are most commonly used in almost all fields of engineering.

(iii) Regenerators or storage type heat exchangers.

In these types of heat exchangers, the hot and cold fluids flow alternatively on the same surface. When hot fluid flows in an interval of time, it gives its heat to the surface, which stores it in the form of an increase in its internal energy. This stored energy is transferred to cold fluid as it flows over the surface in next interval of time. Thus the same surface is subjected to periodic heating and cooling. In many applications, a rotating disc type matrix is used, the continuous flow of both the hot and cold fluids are maintained. These are preheaters for steam power plants, blast furnaces, oxygen producers etc. A stationary and rotating matrix shown in Figure 6.2 are examples of storage type of heat exchangers.

The storage type of heat exchangers is more compact than the transfer type of heat exchangers with more surface area per unit volume. However, some mixing of hot and cold fluids is always there.

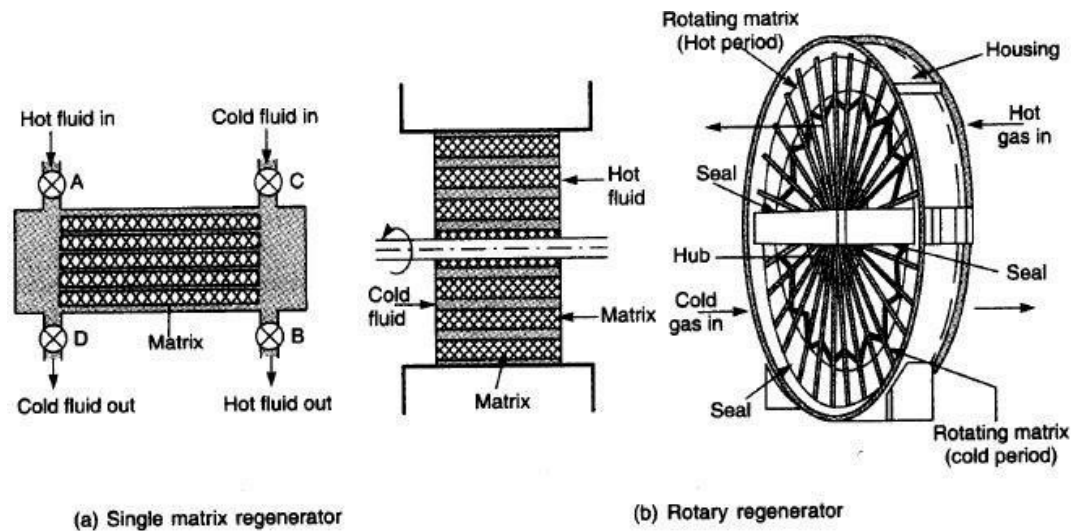

Figure 6.2: Storage type heat exchangers

According to Constructional Features:

- (i) **Tubular heat exchanger.** These are also called tube in tube or concentric tube or double pipe heat exchanger as shown in Figure 6.3. These are widely used in many sizes and different flow arrangements and type.

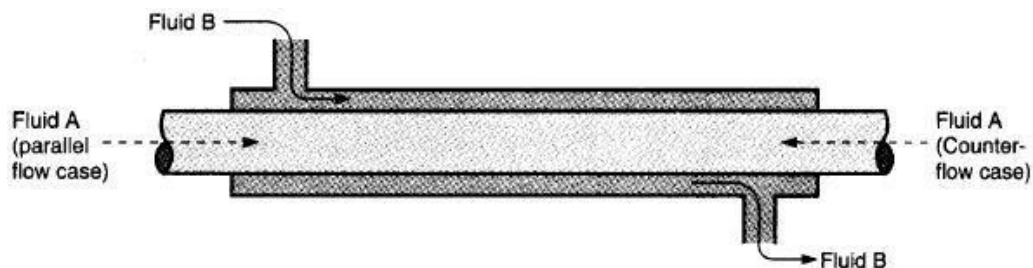

Figure 6.3: Tubular heat exchanger

- (ii) **Shell and tube type heat exchanger.**

These are also called surface condensers and are most commonly used for heating, cooling, condensation or evaporation applications. It consists of a shell and a large number of parallel tubes housing in it. The heat transfer takes place as one fluid flows through the tubes and other fluid flows outside the tubes through the shell. The baffles are commonly used on the shell to create turbulence and to keep the uniform spacing between the tubes and thus to enhance the heat transfer rate. They are having large surface area in small volume. A

typical shell and tube type heat exchanger is shown in Figure 6.4. The shell and tube type heat exchangers are further classified according to number of shell and tube passes involved. A heat exchanger with all tubes make one U turn in a shell is called *one shell pass and two tube pass* heat exchanger. Similarly, a heat exchanger that involves two passes in the shell and four passes in the tubes is called a *two shell pass and four tube pass* heat exchanger as shown in Figure 6.5.

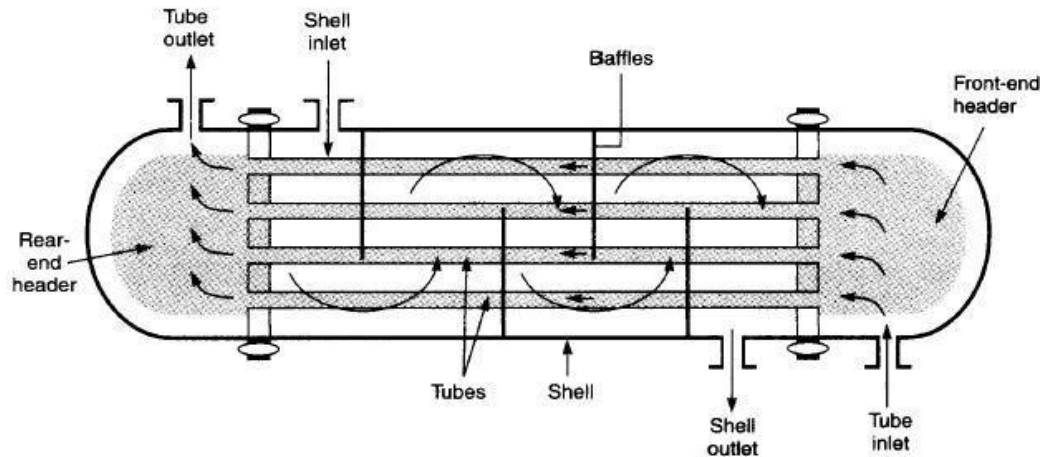

Figure 6.4: Shell and tube type heat exchanger: one shell and one tube pass

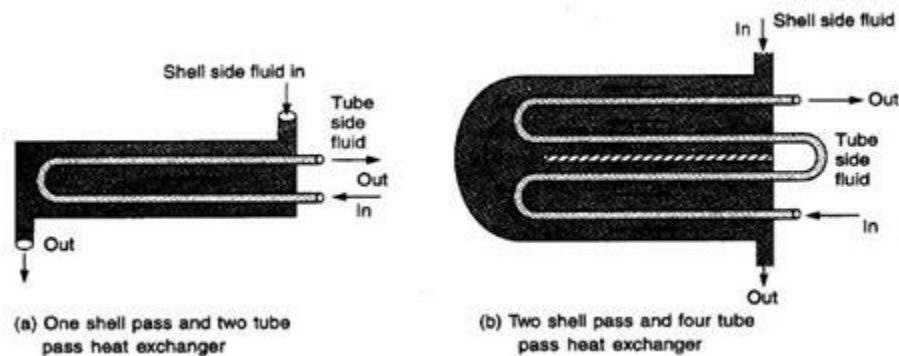

Figure 6.5: Multipass flow arrangement in shell and tube type heat exchanger

(iii) **Finned tube** type. When a high operating pressure or an enhanced heat transfer rate is required, the extended surfaces are used on one side of the heat exchanger. These heat exchangers are used for liquid to gas heat exchange. Fins are always added on gas side. The finned tubes are used in gas turbines, automobiles, aero planes, heat pumps, refrigeration, electronics, cryogenics, air-conditioning systems etc. The radiator of an automobile is an example of such heat exchanger.

(iv) **Compact heat exchanger**. These are special class of heat exchangers in which the heat transfer surface area per unit volume is very large. The ratio of heat transfer surface area to the volume is called *area density*. A heat exchanger with an area density greater than $700 \text{ m}^2/\text{m}^3$ is called *compact heat exchanger*. The compact heat exchangers are usually cross flow, in which the two fluids usually flow perpendicular to each other. These heat exchangers have dense arrays of finned tubes or plates, where at least one of the fluid used is gas. For example, automobile radiators have an area density in order of $1100 \text{ m}^2/\text{m}^3$.

According to Flow Arrangement:

(i) **Parallel flow**: The hot and cold fluids enter at same end of the heat exchanger, flow through in same direction and leave at other end. It is also called the concurrent heat exchanger Figure 6.6.

(ii) **Counter flow**: The hot and cold fluids enter at the opposite ends of heat exchangers, flow through in opposite direction and leave at opposite ends Figure 6.6.

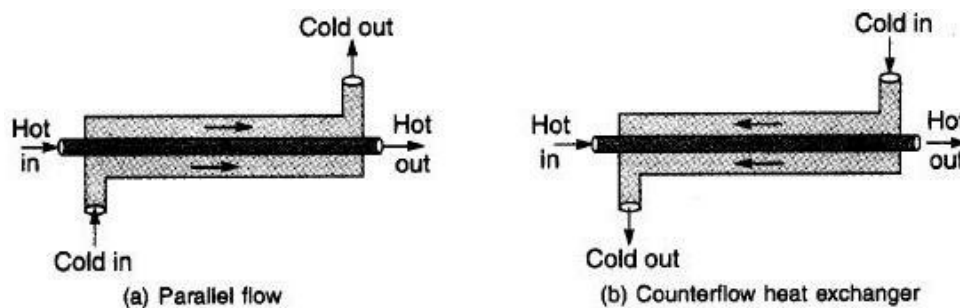

Figure 6.6: Concentric tube heat exchanger

(iii) **Cross flow**: The two fluids flow at right angle to each other. The cross flow heat exchanger is further classified as unmixed flow and mixed flow depending on the flow configuration. If both the fluids flow through individual channels and are not free to move in transverse direction, the arrangement is called unmixed as shown in Figure 6.7a. If any fluid flows on the surface and free to move in transverse direction, then this fluid stream is said to be mixed as shown in Figure 6.7b.

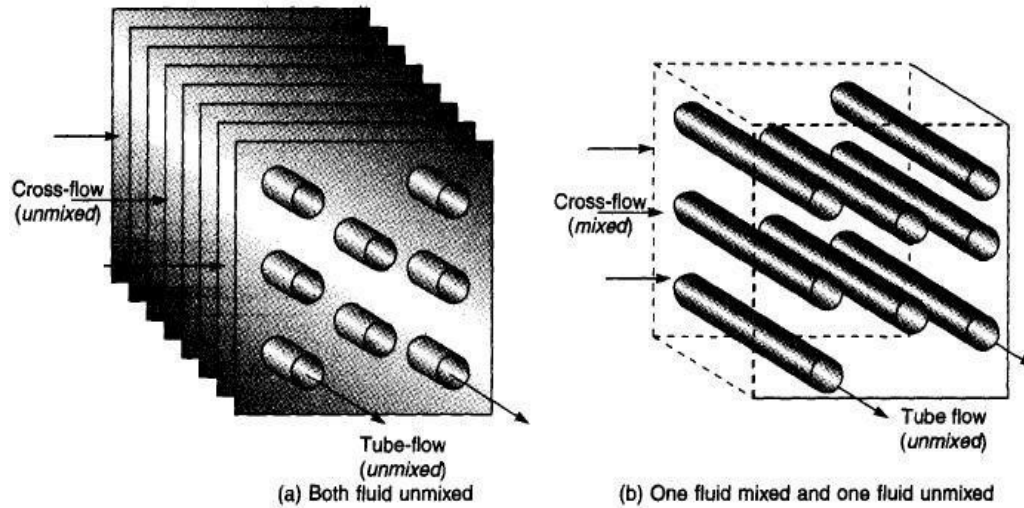

Figure 6.7: Different flow configurations in cross-flow heat exchangers.

Fouling factor:

Material deposits on the surfaces of the heat exchanger tube may add further resistance to heat transfer in addition to those listed below. Such deposits are termed fouling and may significantly affect heat exchanger performance.

We know, the surfaces of heat exchangers do not remain clean after it has been in use for some time. The surfaces become fouled with scaling or deposits. The effect of these deposits affecting the value of overall heat transfer coefficient. This effect is taken care of by introducing an additional thermal resistance called the fouling resistance.

- **Scaling** is the most common form of fouling and is associated with inverse solubility salts. Examples of such salts are CaCO_3 , CaSO_4 , $\text{Ca}_3(\text{PO}_4)_2$, CaSiO_3 , $\text{Ca}(\text{OH})_2$, $\text{Mg}(\text{OH})_2$, MgSiO_3 , Na_2SO_4 , LiSO_4 , and Li_2CO_3 .
- **Corrosion fouling** is classified as a chemical reaction which involves the heat exchanger tubes. Many metals, copper and aluminum being specific examples, form adherent oxide coatings which serve to passivate the surface and prevent further corrosion.
- **Chemical reaction fouling** involves chemical reactions in the process stream which results in deposition of material on the heat exchanger tubes. When food products are involved this may be termed scorching but a wide range of organic materials are subject to similar problems.

- **Freezing fouling** is said to occur when a portion of the hot stream is cooled to near the freezing point for one of its components. This is most notable in refineries where paraffin frequently solidifies from petroleum products at various stages in the refining process, obstructing both flow and heat transfer.
- **Biological fouling** is common where untreated water is used as a coolant stream. Problems range from algae or other microbes to barnacles.

Heat Exchanger Analysis:

Log mean temperature difference (LMTD) method for parallel & counter flow heat exchangers

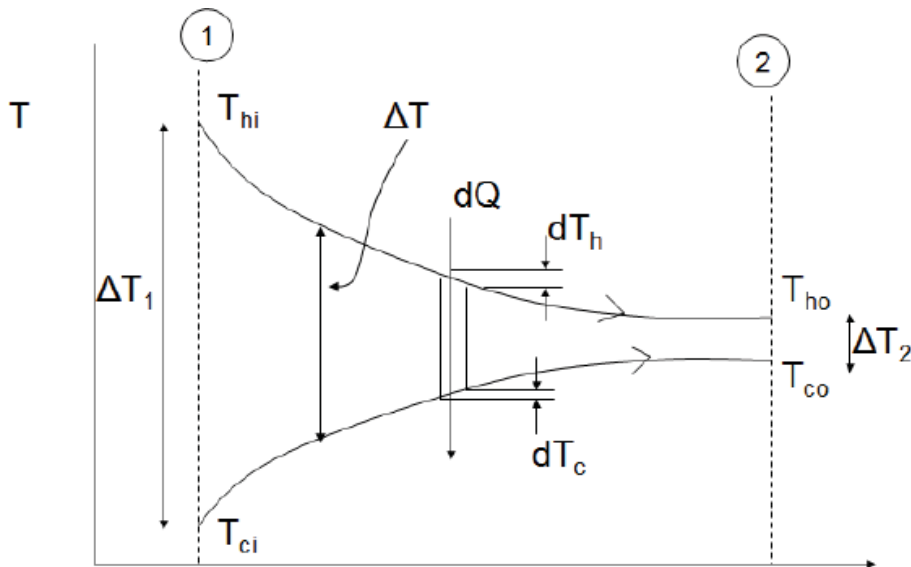

$$Q = \dot{m} c_p (T_{\text{Fluid-in}} - T_{\text{Fluid-out}})$$

$$Q_H = \dot{m}_H c_{pH} (T_{Hi} - T_{Ho})$$

$$Q_C = \dot{m}_C c_{pC} (T_{Co} - T_{Ci})$$

$$dQ_H = -dQ_C = dQ$$

$$dQ_H = \dot{m}_H C_{pH} dT_H$$

$$dQ_C = \dot{m}_C C_{pC} dT_C$$

The overall change in temperature difference across the element is given by:

$$d(\Delta T) = dT_H - dT_C$$

$$d(\Delta T) = -dQ \left[\frac{1}{\dot{m}_H C_{pH}} + \frac{1}{\dot{m}_C C_{pC}} \right]$$

From Equation 5.1 we know that

$$Q = U A \Delta T \quad \rightarrow \quad dQ = U dA \Delta T$$

which gives

$$\frac{dQ}{dA} = U \Delta T$$

Where $\Delta T = T_H - T_C$ at any point

Combining Equations 5.29 and 5.30 to eliminate dQ :

$$\left[\frac{d\Delta T}{\frac{1}{\dot{m}_H C_{pH}} + \frac{1}{\dot{m}_C C_{pC}}} \right] = -U \Delta T dA$$

Rearranged,

$$\frac{d\Delta T}{\Delta T} = -U \left[\frac{1}{\dot{m}_H C_{pH}} + \frac{1}{\dot{m}_C C_{pC}} \right] dA$$

Integrating from point 1 at inlet to point 2 at exit:

$$\int_1^2 \frac{d\Delta T}{\Delta T} = -U \left[\frac{1}{\dot{m}_H C_{pH}} + \frac{1}{\dot{m}_C C_{pC}} \right] \int_1^2 dA$$

For the parallel flow heat exchanger:

$$\Delta T_1 = T_{h,i} - T_{c,i} \quad (5.35)$$

$$\Delta T_2 = T_{h,o} - T_{c,o} \quad (5.36)$$

Integrating 5.34 and substituting $\dot{m}C_p = Q / \Delta T$:

$$\ln \left(\frac{\Delta T_2}{\Delta T_1} \right) = -\frac{UA}{Q} (T_{h,i} - T_{h,o} + T_{c,o} - T_{c,i}) = -\frac{UA}{Q} (\Delta T_1 - \Delta T_2)$$

Rearranging:

$$Q = UA \left[\frac{\Delta T_2 - \Delta T_1}{\ln \left(\frac{\Delta T_2}{\Delta T_1} \right)} \right] = UA \Delta T_m$$

Where ΔT_m is the Log Mean Temperature Difference (LMTD) defined as:

$$\Delta T_m = \left[\frac{\Delta T_2 - \Delta T_1}{\ln \left(\frac{\Delta T_2}{\Delta T_1} \right)} \right]$$

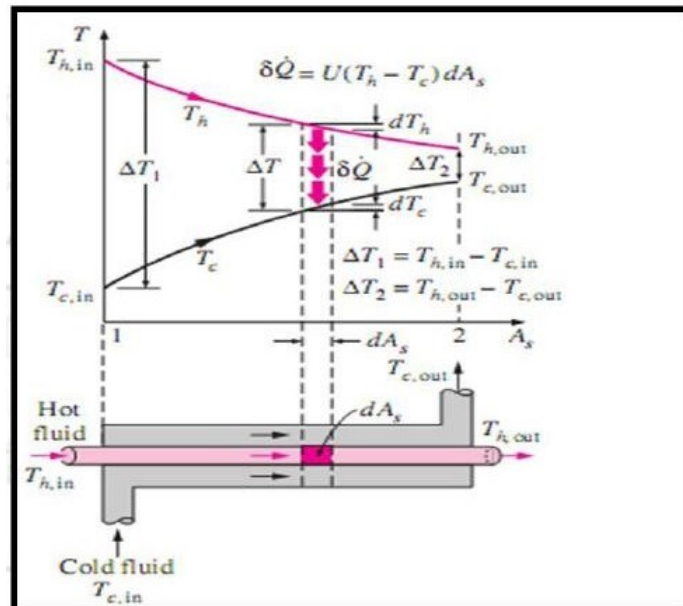
Effectiveness-NTU method:

The effectiveness of heat exchanger given by:

$$\varepsilon = q / q_{\max}$$

The q_{\max} is the maximum possible heat transfer. It's given by;

$$q_{\max} = C_{\min} (t_{h1} - t_{c2})$$

Therefore;

$$\varepsilon = C_h (t_{h1} - t_{h2}) / C_{\min} (t_{h1} - t_{c1})$$

or

$$\varepsilon = C_c (t_{c2} - t_{c1}) / C_{\min} (t_{h1} - t_{c1})$$

Rate of heat transfer then given by;

$$q = \varepsilon * C_{\min} (t_{h1} - t_{c1})$$

$$dQ = U dA(t_h - t_c)$$

$$dQ = -C_h \cdot dt_h = C_c \cdot dt_c$$

From (2), we have:

$$dt_h = -dQ/C_h \quad \text{and} \quad dt_c = dQ/C_c$$

Substituting value of dQ in equation (1) and rearranging, we get

$$d(t_h - t_c)/(t_h - t_c) = -U dA \left[\frac{1}{C_h} + \frac{1}{C_c} \right]$$

Upon integration:

$$(t_{h2} - t_{c2})/(t_{h1} - t_{c1}) = \exp \left[- (U A/C_h) \{1 + C_h/C_c\} \right]$$

$$\varepsilon = C_h(t_{h1} - t_{h2})/C_{\min}(t_{h1} - t_{c1}) = C_c(t_{c2} - t_{c1})/C_{\min}(t_{h1} - t_{c1})$$

Hence,

$$t_{h2} = t_{h1} - (\varepsilon C_{\min}(t_{h1} - t_{c1})/C_h)$$

$$\text{and } t_{c2} = t_{c1} + (\varepsilon C_{\min}(t_{h1} - t_{c1})/C_c)$$

$$\varepsilon = 1 - \exp \left[- (U A/C_h) \{1 + C_h/C_c\} / \{C_{\min}[(1/C_h) + (1/C_c)]\} \right]$$

If $C_h < C_c$, then $C_{\min} = C_h$ and $C_{\max} = C_c$, equation (6) becomes:

$$\varepsilon = 1 - \exp \left[- (U A/C_{\min}) \{1 + C_{\min}/C_{\max}\} / \{C_{\min}[(1/C_{\min}) + (1/C_{\max})]\} \right]$$

The NTU is given by:

$$\varepsilon = \frac{1 - \exp[-NTU(1+R)]}{1+R}$$

UNIT - 5
BOILING AND
CONDENSATION

Introduction:

The condensation sets in, whenever saturation vapour comes in contact with surface whose temp is lower than saturation temp corresponding to vapour pressure. It is the reverse of boiling process.

This process occurs whenever saturation vapour comes in contact with surface whose temp is lower than saturation temp corresponding to vapour pressure. As the vapour condenses, the latent heat is liberated and there is flow of heat to the surface. The liquid condensate may get sub cooled by contact with the cooled surface and that may eventually cause more vapour to condensate on the exposed surface or upon the previously formed condensate.

Types of condensation:

- Film wise condensation
- Drop wise condensation

Film wise condensation:

If the condensate tends to wet the surface and thereby forms a liquid film, then process is known as film condensation. The heat transferred from vapour to condensate formed on surface by convection and further from film to cooled surface by conduction. This combined mode of heat transfer reduces the rate of heat transfer and hence it's heat transfer rates are lower.

Drop wise condensation:

In this, vapour condenses into small liquid droplets of various sizes and which fall down surface in random fashion. A large portion of surface exposed to vapour without an insulating film of condensate liquid; hence higher rates of heat transfer (order of 750 kW/m²) are achieved. Coefficient of heat transfer is 5 to 10 times larger than with film condensation. Yet this type is extremely difficult to maintain or achieve.

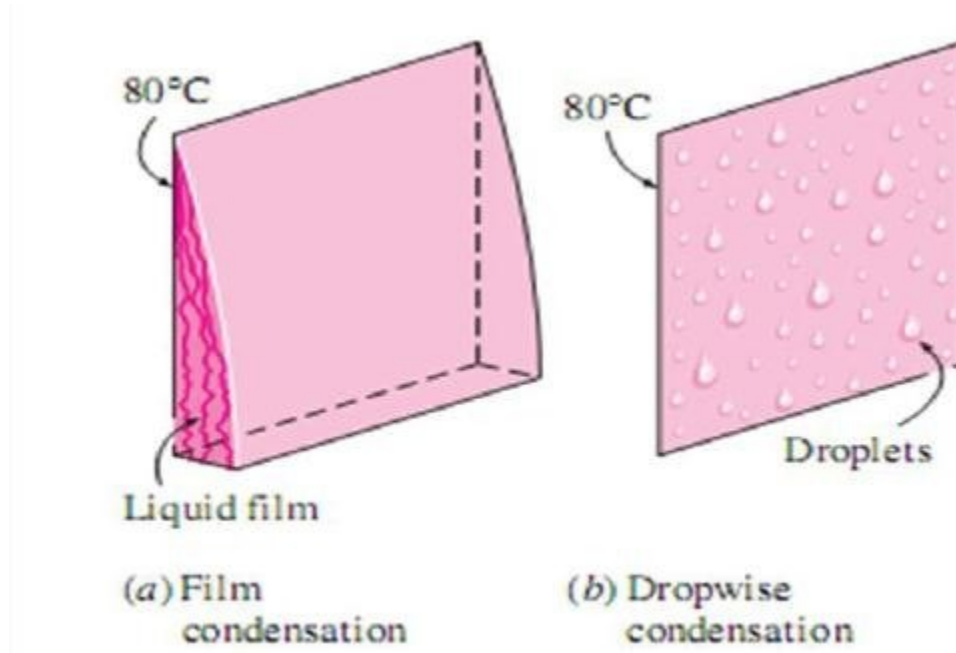

Laminar film condensation on a vertical wall:

Film wise condensation on a vertical plate can be analyzed on lines proposed by Nusselt (1916). Unless the velocity of the vapor is very high or the liquid film very thick, the motion of the condensate would be laminar. The thickness of the condensate film will be a function of the rate of condensation of vapor and the rate at which the condensate is removed from the surface. On a vertical surface the film thickness will increase gradually from top to bottom as shown in Fig. Nusselt's analysis of film condensation makes the following simplifying assumptions

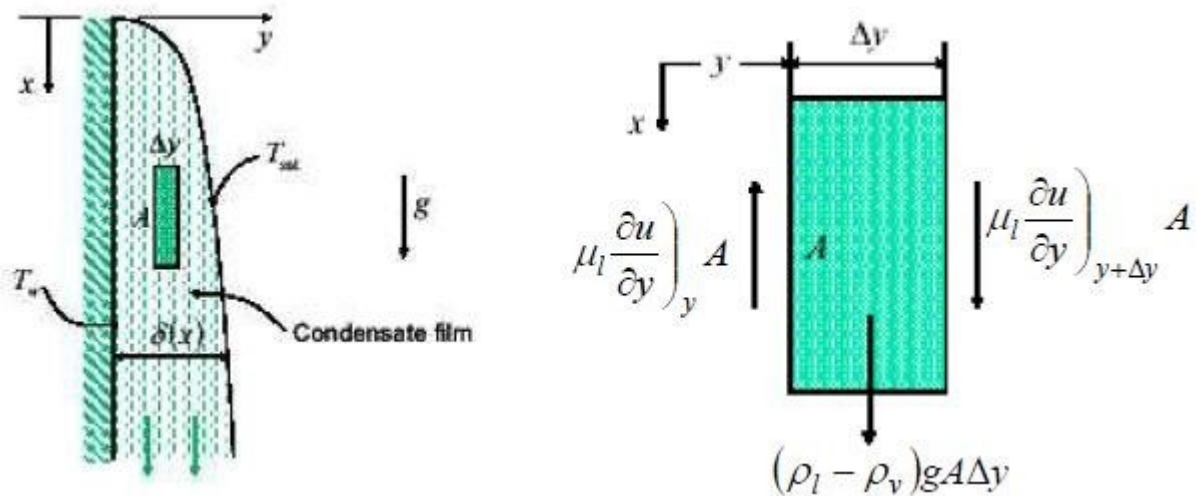

$$\delta(x) = \left[\frac{4xk_l(T_{sat} - T_w)\nu_l}{h_{fg}g(\rho_l - \rho_v)} \right]^{1/4}$$

$$h(x) = \left[\frac{h_{fg}g(\rho_l - \rho_v)k_l^3}{4x(T_{sat} - T_w)\nu_l} \right]^{1/4}$$

$$\text{Average coeff.} \quad \bar{h}_L = 0.943 \left[\frac{h_{fg}g(\rho_l - \rho_v)k_l^3}{L(T_{sat} - T_w)\nu_l} \right]^{1/4}$$

where L is the plate length.

$$\text{Total heat transfer rate :} \quad q = \bar{h}_L A (T_{sat} - T_w)$$

$$\text{Condensation rate :} \quad \dot{m} = \frac{q}{h_{fg}} = \frac{\bar{h}_L A (T_{sat} - T_w)}{h_{fg}}$$

BOILING:

Introduction:

Boiling is a convection process involving a change in phase from liquid to vapor. Boiling may occur when a liquid is in contact with a surface maintained at a temperature higher than the saturation temperature of the liquid. If heat is added to a liquid from a submerged solid surface, the boiling process is referred to as **pool boiling**. In this process the vapor produced may form bubbles, which grow and subsequently detach themselves from the surface, rising to the free surface due to buoyancy effects. A common example of pool boiling is the boiling of water in a vessel on a stove. In contrast, **flow boiling or forced convection boiling** occurs in a flowing stream and the boiling surface may itself be a portion of the flow passage. This phenomenon is generally associated with two phase flows through confined passages.

A necessary condition for the occurrence of pool boiling is that the temperature of the heating surface exceeds the saturation temperature of the liquid. The type of boiling is determined by the temperature of the liquid. If the temperature of the liquid is below the saturation temperature, the process is called sub cooled or local boiling. In local boiling, the bubbles formed at the surface eventually condense in the liquid. If the liquid is maintained at saturation temperature, the process is called saturated or bulk boiling.

There are various distinct regimes of pool boiling in which the heat transfer mechanism differs radically. The temperature distribution in saturated pool boiling with a liquid vapor interface is shown in the Figure

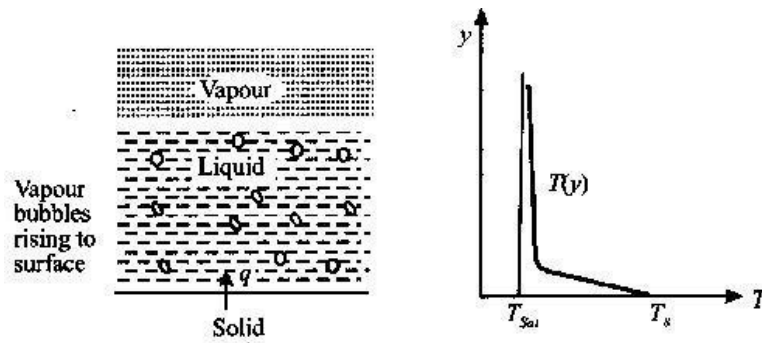

Regimes of pool boiling:

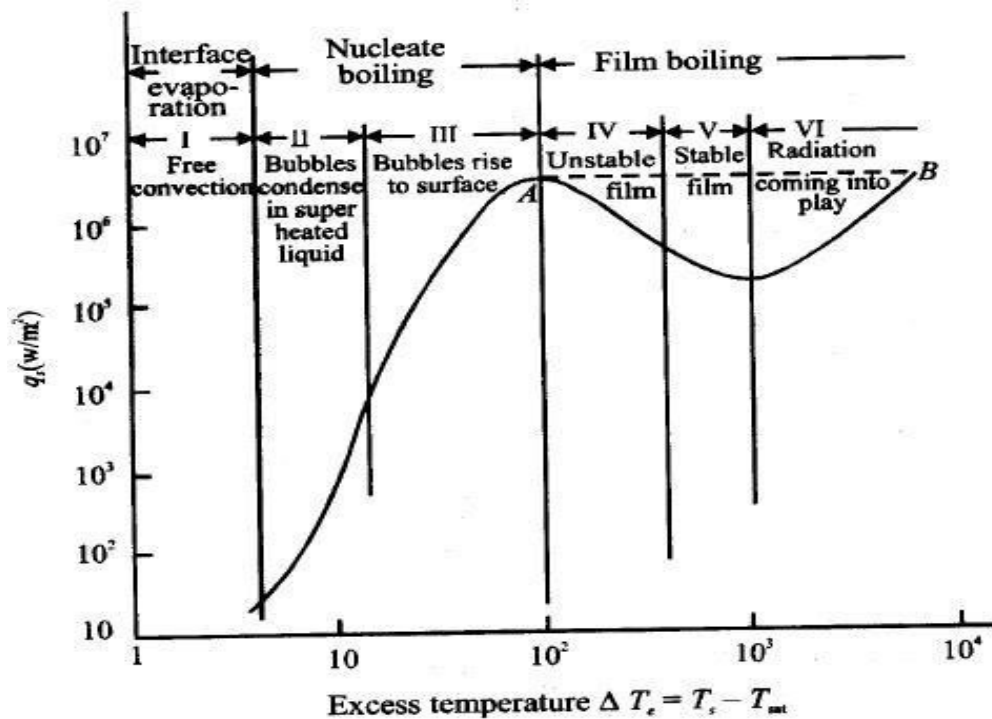

The different regimes of boiling are indicated in Figure 2. This specific curve has been obtained from an electrically heated platinum wire submerged in water by varying its surface temperature and measuring the surface heat flux q_s . The six regimes of Figure 2 will now be described briefly.

In region I, called the free convection zone, the excess temperature, ΔT is very small and $\leq 5^\circ\text{C}$. Here the liquid near the surface is superheated slightly, the convection currents circulate the liquid and evaporation takes place at the liquid surface.

Nucleate boiling exists in regions II and III. As the excess temperature, ΔT is increased, bubbles begin to form on the surface of the wire at certain localized spots. The bubbles condense in the liquid without reaching the liquid surface. Region II is in fact the beginning of nucleate boiling. As the excess temperating is further increased bubbles are formed more rapidly and rise to the surface of the liquid resulting in rapid evaporation.

This is indicated in region III. Nucleate boiling exists up to $\Delta T \leq 50^\circ \text{C}$. The maximum heat flux, known as the critical heat flux, occurs atpoint A and is of the order of $1\text{MW}/\text{m}^2$.

The trend of increase of heat flux with increase in excess temperature observed up to region III is reversed in region IV, called the film boiling region. This is due to the fact that bubbles now form so rapidly that they blanket the heating surface with a vapor film preventing the inflow of fresh liquid from taking their place. Now the heat must be transferred through this vapor film (by conduction) to the liquid to effect any further boiling. Since the thermal conductivity of the vapor film is much less than that of the liquid, the value of q . must then decrease with increase of ΔT . In region IV the vapor film is not stable and collapses and reforms rapidly. With further increase in ΔT the vapor film is stabilized and the heating surface is completely covered by a vapor blanket and the heat flux is the lowest as shown in region V. The surface temperatures required to maintain a stable film are high and under these conditions a sizeable amount of heat is lost by the surface due to radiation, as indicated in region VI.

The phenomenon of stable film boiling can be observed when a drop of water falls on a red hot stove. The drop does not evaporate immediately but dances a few times on the stove. This is due to the formation of a stable steam film at the interface between the hot surface and the liquid droplet. From Fig.2 it is clear that high heat transfer rates are associated with small values of the excess temperature in the nucleate boiling regime. The equipment used for boiling should be designed to operate in this region only. The critical heat flux point A in Fig.2 is also called the boiling crisis because the boiling process beyond that point is unstable unless of course, point B is reached. The temperature at point B is extremely high and normally above the melting point of the solid. So if the heating of the metallic surface is not limited to point A, the metal may be damaged or it may even melt. That is why the peak heat flux point is called the burnout point and an accurate knowledge of this point is very important. Our aim should be to operate the equipment close to this value but never beyond it.

MASS TRANSFER:

Mass transfer is the movement of molecules of one material into another due to the concentration difference in a system. Mass transfer occurs in the direction of negative concentration gradient, similar to heat transfer in the direction of negative temperature gradient.

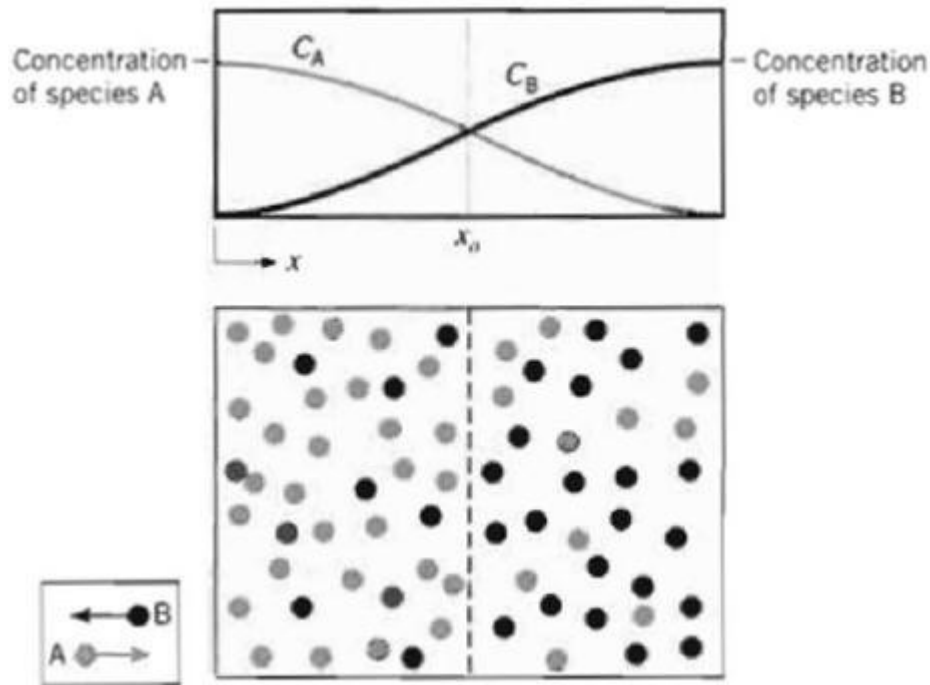
Ficks first law of diffusion:

The Fick's law for the rate of transfer of species A in x-direction in a binary mixture of A and B can be expressed as:

$$\frac{m_A}{A} = -D_{AB} \cdot \frac{dC_A}{dx}$$

Where,

m_A = mass flow rate of species A by diffusion, kg/s

A = area through which mass is flowing, m²

$\frac{m_A}{A}$ = mass flux of species A i.e. amount of species A that is transferred per unit time and per unit area perpendicular to the direction of transfer, kg/s-m²

D_{AB} = diffusion coefficient or mass diffusivity for binary mixture of species A and B, m²/s.

The – ve sign indicates that diffusion takes place in the direction opposite to that of increasing concentration.

RADIATION

Introduction:

Radiation, energy transfer across a system boundary due to a ΔT , by the mechanism of photon emission or electromagnetic wave emission.

Because the mechanism of transmission is photon emission, unlike conduction and convection, there need be no intermediate matter to enable transmission.

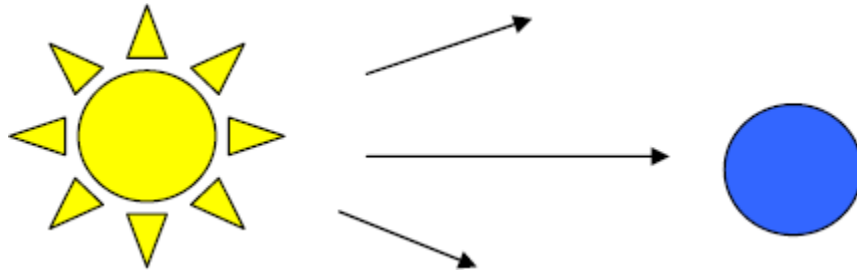

The significance of this is that radiation will be the only mechanism for heat transfer whenever a vacuum is present.

Thermal energy emitted by matter as a result of vibrational and rotational movements of molecules, atoms and electrons. The energy is transported by electromagnetic waves (or photons). Radiation requires no medium for its propagation, therefore, can take place also in vacuum. All matters emit radiation as long as they have a finite (greater than absolute zero) temperature. The rate at which radiation energy is emitted is usually quantified by the modified Stefan-Boltzmann law:

Definitions of various terms used in radiation heat transfer:

- **Stefan-Boltzmann law:**

In 1884, Boltzmann showed that heat flux energy emitted by radiation from an ideal surface called black is proportional to its absolute temperature of fourth power.

$$E_b = \sigma \cdot T_{Abs}^4$$

Where:

E_b = Emissive Power, the gross energy emitted from an ideal surface per unit area, time.

σ = Stefan Boltzmann constant, $5.67 \cdot 10^{-8} \text{ W/m}^2\text{K}^4$

T_{Abs} = Absolute temperature of the emitting surface, K.

- **Kirchoff's law:**

It states that at any temperature the ratio of total emissive power E to the total absorptivity α is a constant for all substances which are in thermal equilibrium with their environment.

- **Planck's law:**

While the Stefan-Boltzmann law is useful for studying overall energy emissions, it does not allow us to treat those interactions, which deal specifically with wavelength, λ . This problem was overcome by another of the modern physicists, Max Planck, who developed a relationship for wave-based emissions.

$$E_{b\lambda} = \frac{C_1}{\lambda^5 \cdot \left[e^{C_2/\lambda T} - 1 \right]}$$

- **Wein's displacement law:**

The behavior of blackbody radiation is described by the Planck Law, but we can derive from the Planck Law two other radiation laws that are very useful. The Wien Displacement Law and the Stefan-Boltzmann Law are illustrated in the following equations.

Steffan - Boltzmann Law:

$$E = \sigma T^4$$

$$\sigma = 5.6705 \times 10^{-5} \text{ erg} \cdot \text{cm}^{-2} \cdot \text{K}^{-4} \cdot \text{sec}^{-1}$$

(Steffan - Boltzmann Constant)

Wien Displacement Law:

$$\lambda_{\text{Max}} = \frac{3 \times 10^7}{T}$$

(λ in Angstroms, T in Kelvin)

Radiation heat exchange between two parallel infinite black surfaces:

View factor and View factor Algebra:

Radiation analysis must take account of the fact that not all of one surface 'sees' all of another. This is characterised by the view factor (sometimes called the radiation configuration factor or shape factor)

The view factor, F , is defined as the fraction of radiation emitted from one surface that is incident upon another. It is usually given two subscripts, F_{ij} , F_{12} , F_{ab} etc. The first subscript refers to the emitting surface the second the receiving surface. The mathematical definition of the view factors F_{ij} and F_{ji} are given by the expressions:

$$F_{ij} = \frac{1}{\pi A_i} \iint_{A_j \cdot A_i} \frac{\cos \theta_i \cos \theta_j dA_i dA_j}{r^2}$$

$$F_{ji} = \frac{1}{\pi A_j} \iint_{A_i \cdot A_j} \frac{\cos \theta_i \cos \theta_j dA_j dA_i}{r^2}$$

The above equations may be integrated to calculate view factors directly. In some cases, the integration can be simplified. View factors are also available for a large number of configurations in tabular, parametric or graphical form for a wide range of geometries. The Catalogue by Howell (1982) provides a comprehensive and useful source of view factor data.

From inspection of the symmetry between equations

$$A_i F_{ij} = A_j F_{ji} \quad (\text{Reciprocity rule})$$

Also for an enclosure of n surfaces:

$$\sum_{j=1}^n F_{ij} = 1 \quad (\text{Summation rule})$$

For a convex or flat surface $F_{ii} = 0$ (it does not 'see' any part of itself)

For a concave surface $F_{ii} > 0$ (it does 'see' part of itself)

Solar Irradiation:

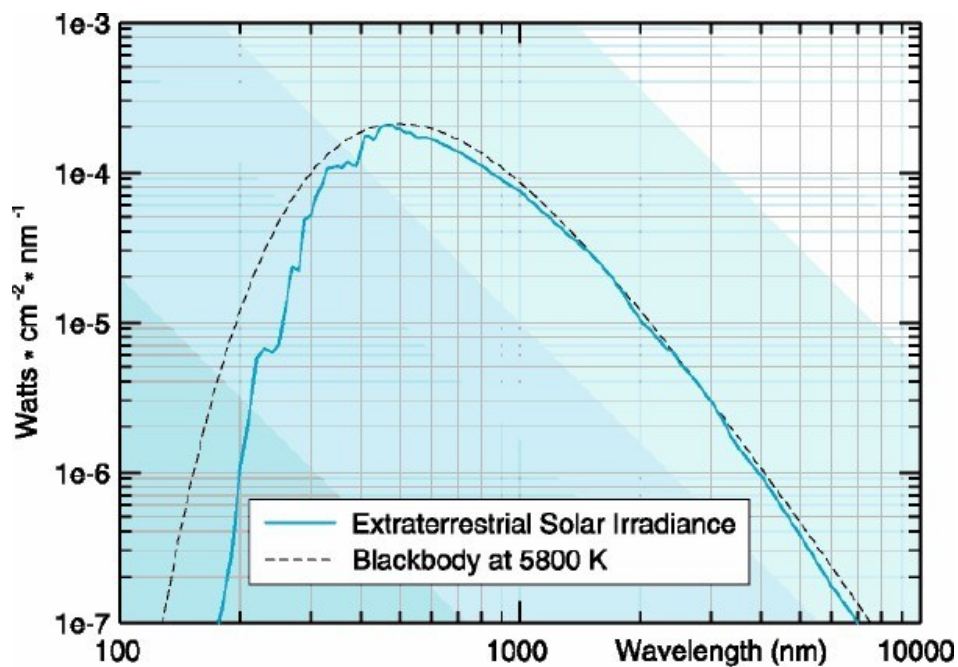

Angles and Arc Length:

We are well accustomed to thinking of an angle as a two-dimensional object. It may be used to find an arc length.

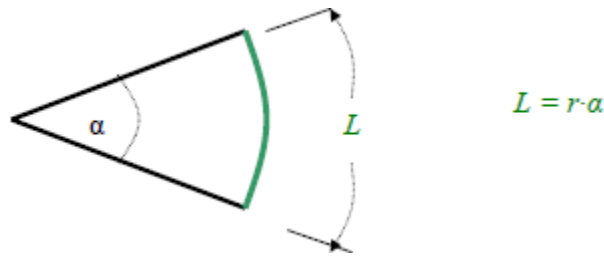
**Solid Angle:**

We generalize the idea of an angle and an arc length to three dimensions and define a solid angle, Ω , which like the standard angle has no dimensions. The solid angle, when multiplied by the radius squared will have dimensions of length squared, or area, and will have the magnitude of the encompassed area.

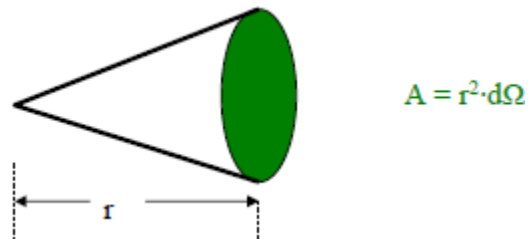
**Projected Area:**

The area, dA_1 , as seen from the perspective of a viewer, situated at an angle θ from the normal to the surface, will appear somewhat smaller, as $\cos \theta \cdot dA_1$. This smaller area is termed the projected area.

$$A_{\text{projected}} = \cos \theta \cdot A_{\text{normal}}$$

