



srivenkateshwarraa
College of Engineering & Technology
(Approved by AICTE, New Delhi & Affiliated to Pondicherry University, Puducherry)
13-A, Pondy - Villupuram Main Road, Ariyur, Puducherry - 605 102.

ASPIRE TO EXCEL



DEPARTMENT OF ELECTRONICS AND COMMUNICATION ENGINEERING

**EC T71 MICROWAVE AND OPTICAL
ENGINEERING NOTES**

IV YEAR/ VII SEM

UNIT 1

Introduction of Microwave devices:

- Microwaves are electromagnetic waves (E.M. waves) having wavelength in the micron range.
- Though microwave frequencies refer to those from 1GHz to 10^6 GHz but generally used for those wavelengths measured in centimeters, roughly from 10cm to 1cm(3 to 30 GHz) and the waves having wavelengths less than 1cm corresponds to higher frequencies(>30 GHz) are called millimeter waves (mm waves).

Microwave Frequencies

Relationship between the frequency and the wavelength of an E.M. wave is

$$\lambda f=c$$

Where,

c - Velocity of electromagnetic radiation, usually called the speed of light.

λ - Wavelength

f- Frequency

Microwave Frequency Band

Designation	Frequency range in GHz
HF	0.003 to 0.03
VHF	0.03 to 0.3
UHF	0.3 to 1.0
L-Band	1.0 to 2.0
S-Band	2.0 to 4.0
C-Band	4.0 to 8.0
X-Band	8.0to 12.0
Ku-Band	12.0 to 27.0
K- Band	18.0 to 27.0
Ka-Band	27.0 to 40.0
Millimeter	40.0 to 300
Sub-millimeter	300 and above.

Microwave devices:

E-PLANE TEE

- Model 3061 E - plane tee are series type T - junction and consists of three section of wave guide joined together in order to divide or compare power levels.
- The signal entering the first port of this T - junction will be equally dividing at second and third ports of the same magnitude but in opposite phase.

H - PLANE TEE

- Model 3065 H - Plane Tee are shunt type T - junction for use in conjunction with VSWR meters, frequency - meters and other detector devices.
- Like in E-plane tee, the signal fed through first port of H - plane Tee will be equally divided in magnitude at second and third ports but in same phase.

MAGIC TEE

- Model 3045 E - H Tee consists of a section of wave guide in both series and shunt wave guide arms, mounted at the exact midpoint of main arm. Both ends of the section of wave guide and both arms are flanged on their ends.
- These Tees are employed in balanced mixers, AFC circuits and impedance measurement circuits etc. This becomes a four terminal device where one terminal is isolated from the input terminal.

DIRECTIONAL COUPLERS

- Model 6000 series Multi-hole directional couplers are useful for sampling a part of Microwave energy for monitoring purposes and for measuring reflections and impedance.
- These consist of a section of Wave guide with addition of a second parallel section of wave guide thus making it a four port network. However the fourth port is terminated with a matched load.
- These two parallel sections are coupled to each other through many holes, almost to give uniform coupling; minimum frequency sensitivity and high directivity. These are available in 3, 6, 10, 20 and 40dB coupling.

CIRCULATORS

- Model 6021 and 6022 are T and Y types of three port circulators respectively. These are precisely machined and assembled to get the desired specifications.
- Circulators are matched three port devices and these are meant for allowing Microwave energy to flow in clockwise direction with negligible loss but almost no transmission in the anti-clockwise direction.

ISOLATORS

- The three port circulators Model 6021 may be converted into isolators by terminating one of its port into matched load.
- These will work over the frequency range of circulators. These are well matched devices offering low forward insertion loss and high reverse isolation.

Gunn diode and its modes of operation:

- A Gunn Diode is considered as a type of diode even though it does not contain any typical PN diode junction like the other diodes, but it consists of two electrodes. This diode is also called as a Transferred Electronic Device.
- This diode is a negative differential resistance device, which is frequently used as a low-power oscillator to generate microwaves.
- It consists of only N-type semiconductor in which electrons are the majority charge carriers. To generate short radio waves such as microwaves, it utilizes the Gunn Effect.

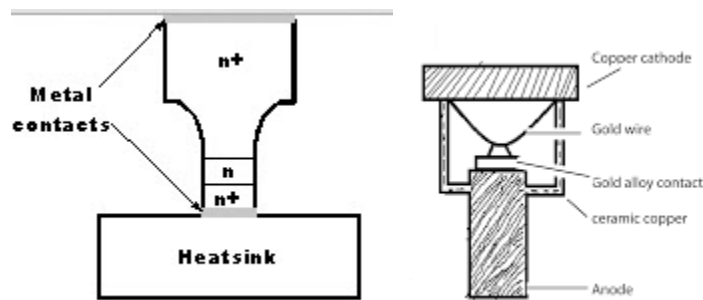

Fig: Structure of Gunn Diode

Construction of Gunn Diode:

- The central region shown in the figure is an active region, which is properly doped N-type GaAs and epitaxial layer with a thickness of around 8 to 10 micrometers.
- The active region is sandwiched between the two regions having the Ohmic contacts.
- A heat sink is provided to avoid overheating and premature failure of the diode and to maintain thermal limits.
- Only N-type material is used, which is due to the transferred electron effect applicable only to N-type materials and is not applicable to the P-type materials. The frequency can be varied by varying the thickness of the active layer while doping.

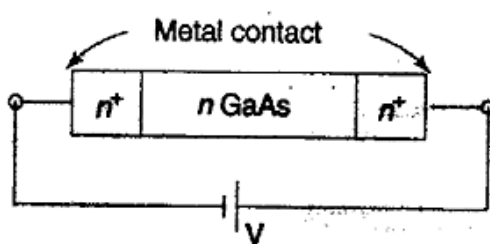

Fig: Gunn Diode

Gunn Effect:

- Gunn-Effect diodes are named after J.B.Gunn, who discovered periodic fluctuations of current passing through the n-type Gallium Arsenide (GaAs) specimen when the applied voltage exceeded a certain critical value.

- The Gunn Effect can be defined as generation of microwave power (power with microwave frequencies of around a few GHz) whenever the voltage applied to a semiconductor device exceeds the critical voltage value or threshold voltage value.

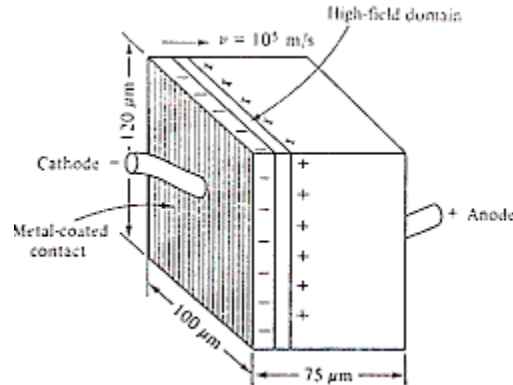
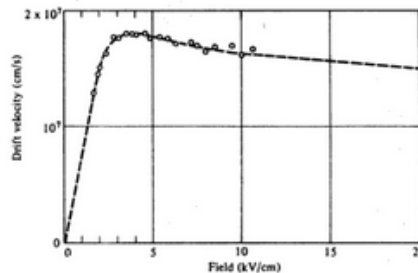

Fig: Structure of Gunn Diode

- Above some critical voltage, corresponding to an electric field of 2000 – 4000 Volts/Km. the period of oscillations will be usually inversely proportional to the specimen length and closely equal to the transit time of electrons between the electrodes.
- Gunn Effect can be explained on basis of two valley theory of Ridley-Watkins-Hilsum (RWH) theory or the transferred electron mechanism.

Negative Resistance

- The carrier drift velocity is linearly increased from zero to a maximum when the electric field is varied from zero to a threshold value.
- When the electric field is beyond the threshold value of 3000 V/cm for the n-type GaAs, the drift velocity is decreased and the diode exhibits negative resistance. This shown in figure below:



Fig; Drift Velocity of n-type Ga-As Vs Electric Field

- The current fluctuations of n-type GaAs diode is shown below: the current waveform was produced by applying a voltage pulse of 16 V amplitude and 10 ns duration to a n-type GaAs 2.5×10^{-3} cm in length. The oscillation was 4.5 GHz

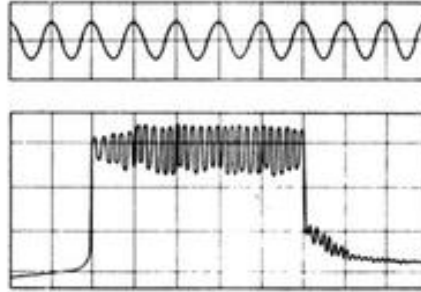

Fig: current waveform of n-type GaAs

- The electrical equivalent circuit of a Gunn diode is shown in figure below:

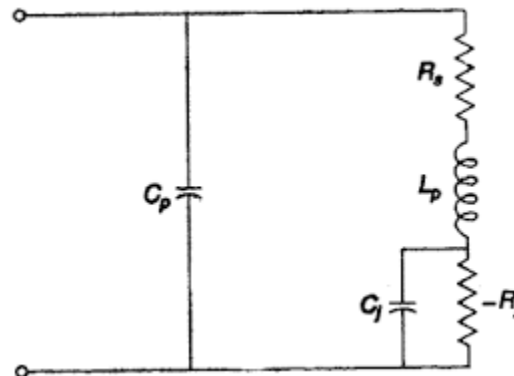

Fig: electrical equivalent circuit of a Gunn diode

Where, $C_j \rightarrow$ diode capacitance

$R_j \rightarrow$ Diode Resistance

$R_s \rightarrow$ Total resistance of leads, ohmic contact

$L_p \rightarrow$ Package Inductance

$C_p \rightarrow$ Package Capacitance

- The negative resistance value that typically lies in the range -5 to -20 ohm.

Modes of operation:

- Depending on the material parameters and operating conditions, a Gunn Effect oscillator can be made to oscillate in any of the four frequency modes.
 - Gunn Oscillation Mode
 - Stable Amplification Mode
 - Limited space charge Accumulator (LSA) Mode
 - Bias-Circuit Oscillation Mode

1. Gunn Oscillation Mode:

- This mode is defined in the region where the product of frequency multiplied by length is about 10^7 cm/s and the product of doping multiplied by length is greater than 10^{12} /cm².
- In this region the device is unstable because of the cyclic formation of either the accumulation layer or the high field domain.
- In a circuit with relatively low impedance the device operates in the high field domain mode and the frequency of oscillation is near the intrinsic frequency.

- When the device is operated in a relatively high- Q cavity and coupled properly to the load, the domain is quenched or delayed (or both) before nucleating.
- In this case, the oscillation frequency is almost entirely determined by the resonant frequency of the cavity and has a value several times the intrinsic frequency.

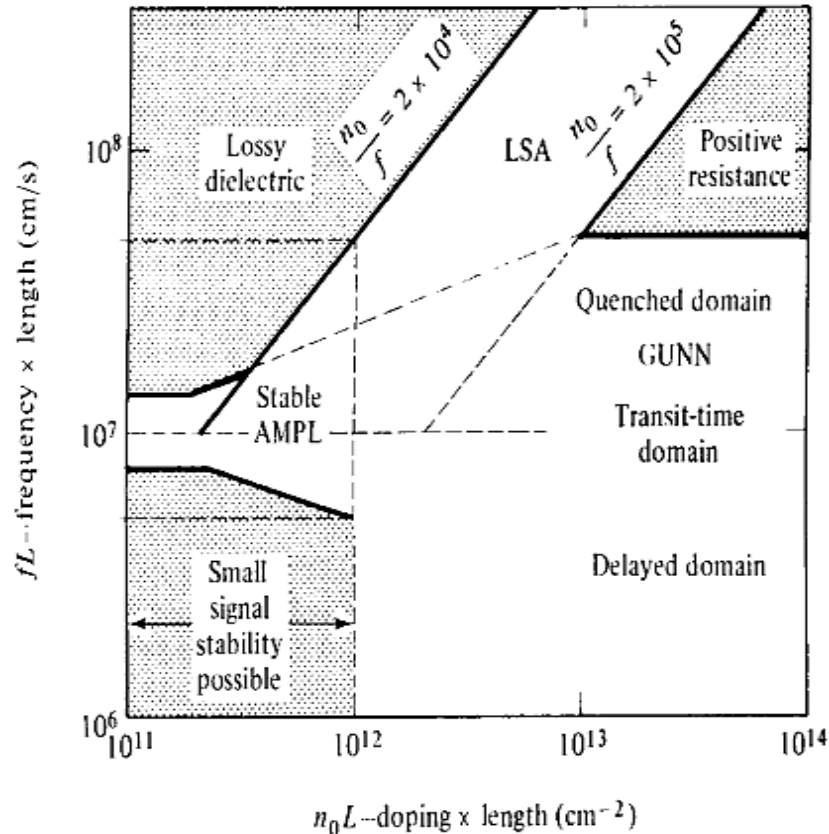

Fig: Modes of Operation of Gunn Diode

- Here, $\epsilon > \epsilon_{th}$. The high field domain drifts along the specimen until it reaches the anode or until the low - field value drops below the sustaining field is required to maintain V_s as shown in the figure. Since the electron drift velocity v varies with E , there are 3 possible modes

a) Transit time domain mode:

- In this mode the period of oscillation is equal to transit time, $\tau_o = \tau_t$ as shown in figure below(a)
- Drift velocity is, $vd = vs = fL = 10^7 \text{ cm/s}$
- Efficiency is low, below 10% because the domain arrives at the anode at a lower current level.
- Operating frequency is lesser than 30 GHz.

b) Delayed or Inhibited Mode

- In this mode the oscillation period is greater than transit time $\tau_o > \tau_t$ as shown in figure below

- The transit time is chosen so that the domain is collected while the electric field $E < E_{th}$. i.e $E < E_{th}$.
- This Delayed or Inhibited Mode has the efficiency of 20 % .Hence the operating frequency can be equal or less than in Gunn diode.
- If the voltage or electric field is applied to GaAs diode (E), initially the current will increase with a rise in the voltage when the diode voltage exceeds a certain threshold value (E_{th}), a high electric field (3.2 KV / m for GaAs) is produced across the active regions.

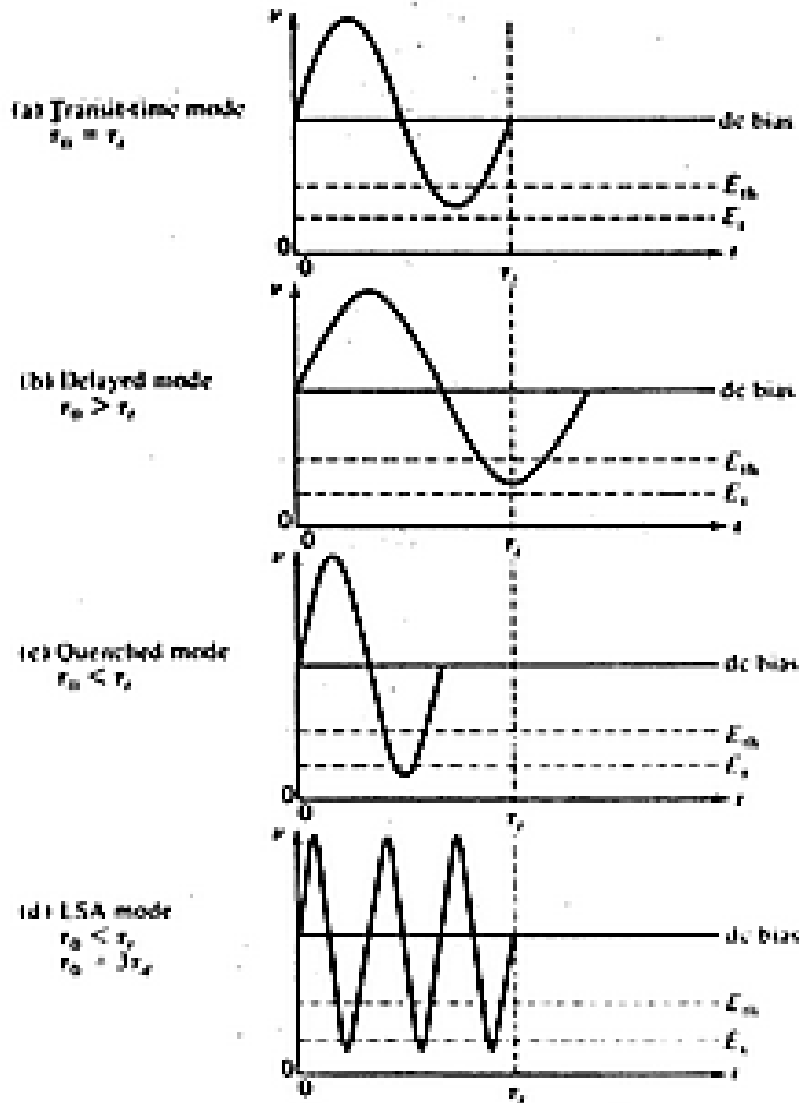

Fig: Mode the oscillation period

c) Quenched Domain Mode:

- When the bias field swings back above the threshold (E_{th}), a new domain will be formed and the process repeats. Hence in this mode, the domain is quenched before

it reaches the anode. Therefore the oscillation period is lesser than the transit time, $\tau_0 < \tau t$.

- The efficiency is only about 13 %.

2. LSA Mode

- This mode is defined in the region where the product of frequency times length is about 10^7 cm/s and the quotient of doping divided by frequency is between 2×10^4 and 2×10^5 .
- The most important mode of operation in Gunn oscillator as this mode gives high power up led with high efficiency.
- The frequency and RF voltage are so chosen that the domain do not have sufficient time to form while the field is above threshold as shown n figure (d) as above. The LSA mode yields high power and high efficiency. Operating frequency is 0.5 – 50 times more than that for Gunn diode.

3. Stable Amplification Mode:

- This mode is defined in the region where the product of frequency times length is about 10^7 cm/s and the product of doping times length is between 10^{18} and 10^{12} /cm².

4. Bias-Circuit Oscillation Mode:

- This mode occurs only there is Gunn or LSA oscillator, and it is usually at the region where the product of frequency times length is too small to appear in the figure.
- When a bulk diode is biased to threshold, the average current suddenly drops as Gunn oscillation begins.
- The drop in current at the threshold can lead to oscillation in the bias circuit that are typically 1 KHz to 100 MHz.

Applications

- In Radar transmitters, Industry telemetry systems, Broadband linear amplifier, Fast combinational and Sequential logic Circuits, Low and medium power oscillator, etc.,

IMPATT and TRAPATT diodes:

- IMPATT diode consists of a high doping avalanching region and a drift region.
- All the above IMPATT diode types and their doping profile is shown in figure below.
- The field applied to the IMPATT diode is about 5KV/cm. The total field across the diode is sum of a RF ac voltage superimposed on high dc voltage.
- When a p-n junction is reverse biased, in the depletion layer, avalanche breakdown takes place. Avalanche current lags the applied field by $\pi/2$ radians.
- The distances travelled by various carriers are not equal but the additional phase shift caused by the drift of carriers makes the carriers to create a negative resistance.

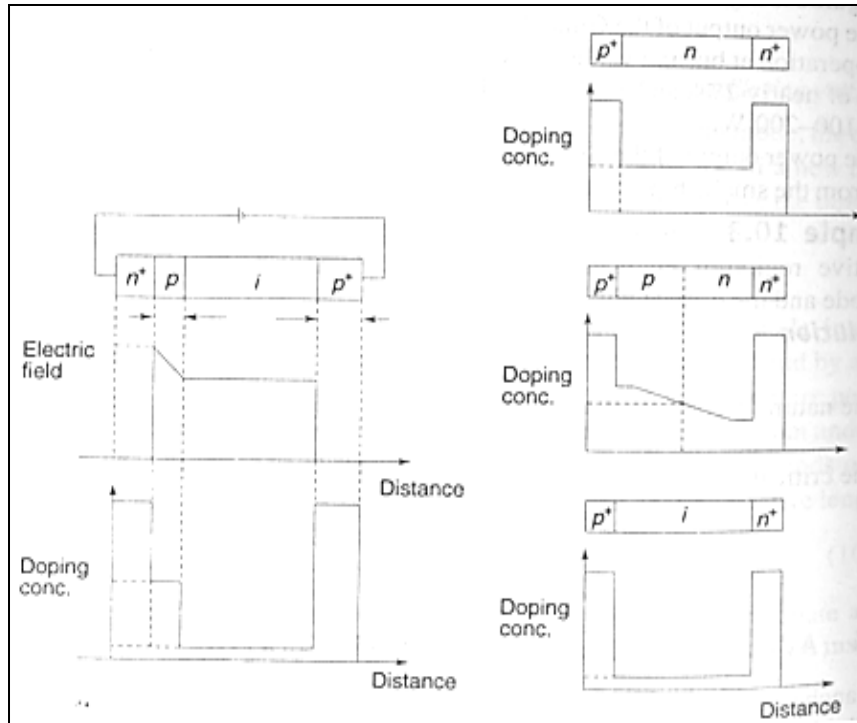

Fig; Various structures of IMPATT diode

- A dc electric field distribution that exists when a large reverse bias is applied across the diode is shown in figure below:

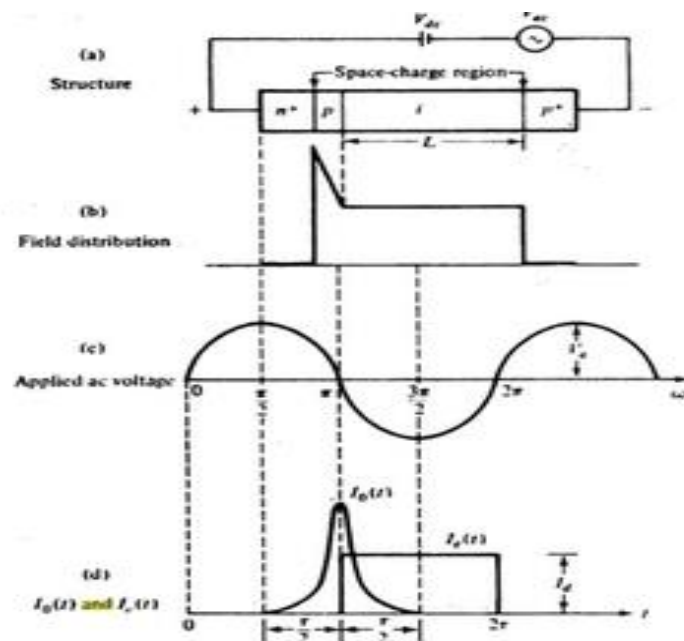

Fig: (a) IMPATT Diode (b) Field Distribution (c) Input Voltage (d) Output Pulse

- The diode is an n^+ - p - i - p^+ structure, where the subscript plus sign denotes very high doping and the 'i' refers to intrinsic material.

- The device consists essentially of two regions. one is the thin p region at which avalanche multiplication occurs. This region is also called the high-field region or the avalanche region. The other is the 'i' region through which the generated holes must drift in moving to the p+ contact. This region is also called the intrinsic region or the drift region.
- The p region is very thin. The space between the 'n+-p' junction and the 'i-p' junction is called the **space-charge region**. Similar devices can be built in the p+-n-i-n+ structure, in which electrons generated from avalanche multiplication drift through the i region.
- IMPATT diode exhibits negative resistance which can be obtained by a junction diode of any doping profile, which in turn delivers power from the dc bias to the oscillation.

Working Principle

- When the reverse-biased voltage is well above the punch through or breakdown voltage, the space-charge region always extends from the n+-p junction through the p and i regions to the i-p junctions.
- The fixed charges in the various regions are shown fig.(b) above. A positive charge gives a rising field in moving from left to right. The maximum field, which occurs at then+-p junction is about several hundred kilovolts per centimeter.
- Carriers(holes) moving in the high field near n+-p junction acquire energy to knock valence electrons into the conduction band, thus producing hole-electron pairs.
- The rate of pair production or avalanche multiplication is a sensitive nonlinear function of the field. By proper doping, the field can be given a relatively sharp peak so that avalanche multiplication is confined to a very narrow region at the n+-p junction.
- The electrons move into the n+ region and the holes drift through the space charge region to the p+ region with a constant velocity v_d of about 10^3 cm/s for silicon.
- The field throughout the space charge region is above about 5 KV/cm.
- The transit time of a hole across the drift i-region of length L is given by $\tau = \frac{L}{v_d}$

Operating Frequency

Thus, the operating frequency around the π transit angle is

$$f = \frac{1}{2\tau}$$

Where τ is the transit time

On substituting the value of τ , then can be expressed as

$$f = \frac{V_d}{2L}$$

Where,

τ - Transit time

V_d – Drift velocity (m/s)

L – Drift Length (m)

- When the holes generated at the n+-p junction drift through the space charge region, they cause a reduction of the field in accordance with poisson's equation;

$$\frac{\partial E}{\partial x} = -\frac{\rho}{\epsilon s}$$

Where,

ρ -Volume charge density

ϵs -semiconductor permittivity

where, ρ – volume charge density and ϵs – semiconductor permittivity.

- Since the drift velocity of the holes in the space charge region is constant, the induced current $I_e(t)$ in the external circuit is simply equal to

$$I_e(t) = \frac{Q}{\tau} = \frac{vdQ}{L}$$

Where,

v_d - drift velocity,

Q-total charge of the moving holes,

L – drift Length

- When, the pulse of hole current $I_o(t)$ is suddenly generated at the n+-p junction, a constant current $I_e(t)$ starts flowing in the external circuit and continues to flow during the time τ in which the holes are moving across the space-charge region.
- Thus, on the average, the external current $I_e(t)$ because of the moving holes is delayed by $\tau/2$ or 90° relative to the ac voltage as shown in figure (d) above.

Output Power

- The external current approaches a square wave, being very small during the positive half cycle of the ac voltage and almost constant during the negative half cycle.
- Since the direct current supplied by the dc bias is the average external current or conductive current, it follows that the amplitude of variation of $I_e(t)$ is approximately equal to I_d . If V_o is the amplitude of the ac voltage, the ac power delivered is found to be

$$P = 0.707 V_o I_d \text{ W/unit area}$$

- The capacitance across the space-charge is given by,

$$C = \frac{\epsilon s A}{L}$$

- The maximum output power is given by

$$P_m = I_m V_m$$
$$i. e., P_m = \frac{E m^2 \cdot v d^2}{4\pi^2 X c}$$

Efficiency

The efficiency of the IMPATT diode is given by,

$$\eta = \frac{P_{ac}}{P_{dc}}$$
$$\eta = \frac{V_a I_a}{V_d I_d}$$

Advantages

- It is wideband
- Pulse power is high
- Suitable for high frequency

Disadvantages

- It is a noisy device
- Tuning range is not high

Application of IMPATT Diode

- As microwave oscillator
- As modulated oscillator
- As receiver local oscillator
- As parametric amplifier pump
- In radar reception
- In communication transmission
- As negative resistance

TRAPATT diodes:

Construction

- TRAPATT diode is derived from IMPATT diode.
- In TRAPATT diodes the doping level between the junction and anode changes gradually. Silicon or Gallium Arsenide is used for fabricating TRAPATT diodes.
- Figure shows the construction of TRAPATT diode.
- Construction of avalanche $p^+ - n - n^+$ is shown but when better power dissipation is required $n^+ - p - p^+$ structure is preferred.

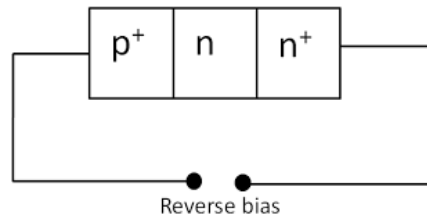

Working Principle

- A square current pulse is used to excite TRAPATT diode.

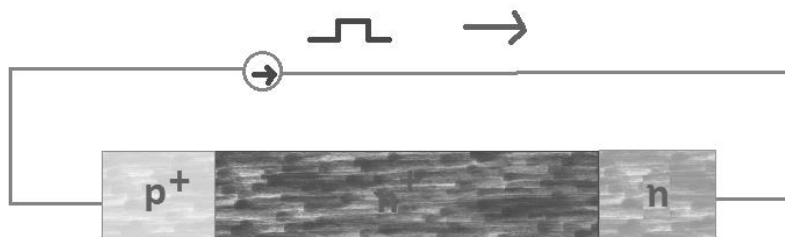

- As soon as diode is excited the charge is accumulated in the depletion region at the junction and the electric field across the junction increases linearly.
- When the sufficient carriers are generated it then depress throughout the depletion region, causing the voltage to fall down.
- During the interval formation of plasma takes place. Voltage and current continue to decrease to residual value and the plasma is extracted from the region.
- As the residual charge is removed, the voltage increase further and diode charges again.

- At some point the diode is charged fully and maintains a constant voltage across it while current drops down.
- When current comes back the cycle repeats.

VI Characteristics of TRAPATT diode

- The voltage and current waveforms for a avalanche TRAPATT diode is shown in figure below.

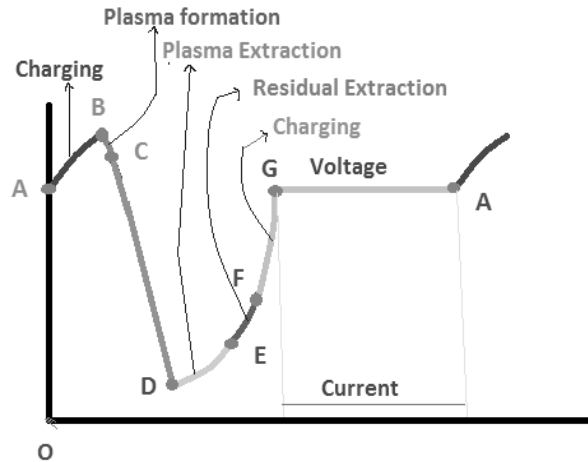

Fig(a): voltage and current waveforms for a avalanche TRAPATT diode

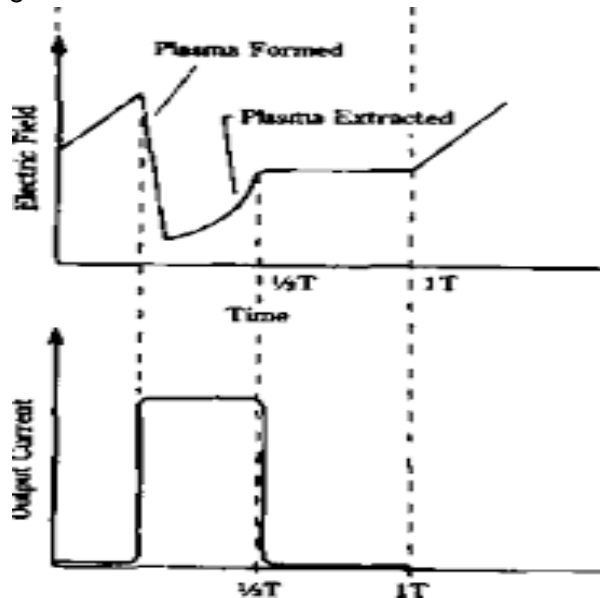

Fig(b): voltage and current waveforms for a avalanche TRAPATT diode

- The current density is given by

$$J = \epsilon_s \frac{dE}{dt}$$

Where, ϵ_s – permittivity of the diode

E – Applied Electric field

- The electric field is given by,

$$E(x, t) = Em \frac{qNa}{\epsilon_s} x + \frac{J}{\epsilon_s}$$

Where, E_m – Maximum electric field

Q – Charge of an electron

N_a – Doping concentration

ϵ_s – Permittivity

x – Distance

J – Current density

- The avalanche zone velocity is given by,

$$V_z = \frac{dx}{dt}$$
$$V_z = \frac{1}{qNa}$$

Application of TRAPATT Diode

1. In pulsed radar as local oscillator
2. In radio altimeter
3. Air borne and marine radars

Limitations of TRAPATT Diode

- TRAPATT diodes are very sensitive to the harmonics, thus when operated in fundamental mode precaution is to be taken that the second, third and fourth harmonics cannot be maintained in the circuit.

Microwave bipolar transistor:

- The invention of the transistor (contraction for transfer resistor) by William Shockley and his coworkers at Bell Laboratory in 1948 had a revolutionary impact on electronic technology in general and on solid-state devices in particular.
- Since then transistors and related semiconductor devices have replaced vacuum tubes for lower-power sources. Microwave power transistor technology has advanced significantly during the past three decades.
- The microwave transistor is a nonlinear device, and its principle of operation is similar to that of the low-frequency device, but requirements for dimensions, process control, heat sinking, and packaging are much more severe.
- For microwave applications, the silicon (Si) bipolar transistors dominate for frequency range from UHF to about S band (about 3 GHz).
- As the technology improves, the upper frequency limit for these devices is continuously being extended, and at the present time the devices are capable of producing useful power up to 22 GHz.

Physical Structures

- All microwave transistors are now planar in form and almost all are of the silicon N-p-n type. The geometry can be characterized as follows: (a) interdigitated, (b) overlay, and (c) matrix (also called mesh or emitter grid) as shown in below Fig.

- The interdigitated type is for a small signal and power, but the overlay type and Matrix type are for small power only.
- For high-frequency applications, the n-p-n structure is preferred because the electron mobility ($\mu_n = 1500 \text{ cm}^2/\text{V} \cdot \text{s}$) is much higher than the hole mobility ($\mu_p = 450 \text{ cm}^2/\text{V} \cdot \text{s}$). The above figure shows an example of the densities for an n-p-n transistor.
- The density unit is in $\text{cm}^2/\text{V} \cdot \text{s}$. Although there are many ways of fabricating a transistor, diffusion and ion implantation is generally used.

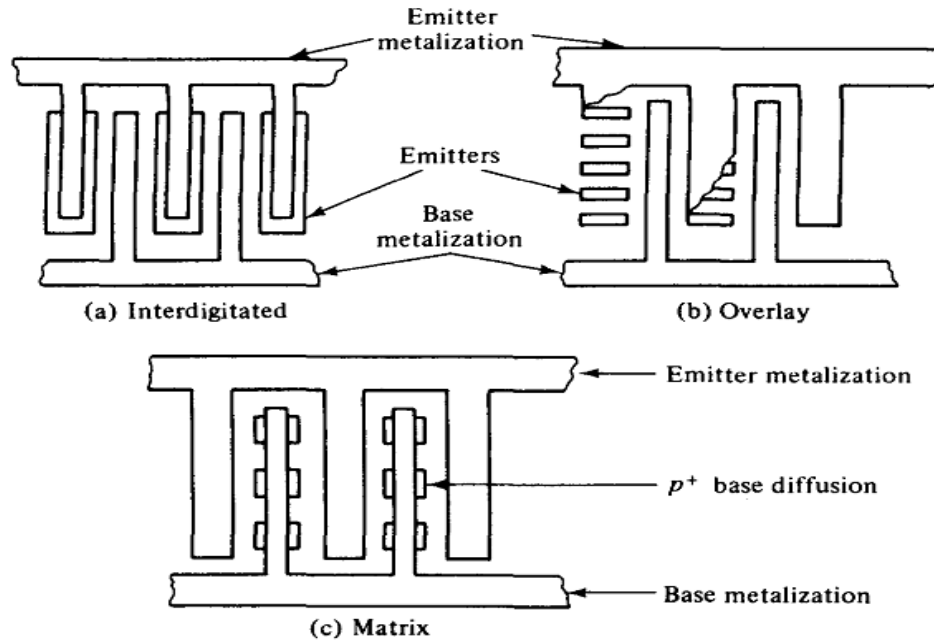

Fig: Geometry of all microwave transistors

- For example, the structure would typically start with a lightly doped n-type epitaxial layer as the collector. The base region would be formed by counter-doping the base region p-type by diffusion.

Principles of Operation:

The bipolar junction transistor (BJT) is an active three-terminal device which is commonly used as an amplifier or switch. Its principles of operation are discussed in this section. Modes of operation. A bipolar transistor can operate in four different modes depending on the voltage polarities across the two junctions: normal (active) mode, saturation mode, cutoff mode, and inverse (or inverted) mode.

- 1. Normal Mode.** If the emitter junction of an n-p-n transistor is forward-biased and the collector is reverse-biased, the transistor is operated in the normal mode. The term forward bias means that the positive polarity of the bias voltage is connected to the p side and the negative polarity to the n side for a p-n junction; the opposite obtains for reverse bias. Most transistor amplifiers are operated in normal mode, and its common-

base current gain α is known as the normal alpha α_N .

2. **Saturation Mode.** When both transistor junctions are forward-biased, the transistor is in its saturation mode with very low resistance, and acts like a short circuit.
3. **Cutoff Mode.** If both transistor junctions are reverse-biased the transistor is operated in its cutoff mode. As the current is cut off, the transistor acts like an open circuit. Both the cutoff and saturation modes of a transistor are used as switching devices for the OFF and ON states.
4. **Inverse Mode.** When the emitter is reverse-biased and the collector is forward-biased, the transistor is operated in the inverse (or inverted) mode, and its current gain is designated as the inverse alpha α_1 . If the transistor is symmetric, the normal alpha α_N is nearly equal to the inverse alpha α_1 . The two current gains, however, are not actually equal because of their unequal doping. In practice, the inverse mode is not commonly used except as a multiemitter transistor in TTL (transistor-transistor logic) logic gate.

MESFET and Parametric amplifiers:

- If the field-effect transistor is constructed with a metal-semiconductor Schottky-barrier diode, the device is called a metal-semiconductor field-effect transistor (MESFET).
- The material may be either silicon or gallium arsenide (GaAs), and the channel type may be either n channel or p channel.
- Since GaAs MESFETs have the capability of amplifying small signals up to the frequency range of X band with low-noise figure, they have lately replaced the parametric amplifiers in airborne radar systems because the latter are complicated to fabricate and expensive to produce.
- The GaAs MESFET has higher electron mobility, higher electric field, and higher electron saturation drift velocity than silicon devices, so its output power is also greater.
- Another special feature is its lower noise figure, accounted for by its higher electron mobility.
- Therefore the GaAs MESFETs are very commonly used in microwave integrated circuits for high-power, low-noise, and broadband amplifier applications.

Physical Structures

- In GaAs MESFETs the substrate is doped with chromium (Cr), which has an energy level near the center of the GaAs bandgap. As Cr is the dominant impurity, the Fermi level is pinned near the center of the bandgap.
- Thus, a very high-resistivity substrate (near 10⁸ ohm-cm) generally results, and it is commonly called the semi-insulator GaAs substrate.
- On this nonconducting substrate a thin layer of lightly doped n-type GaAs is grown epitaxially to form the channel region of the field-effect transistor.

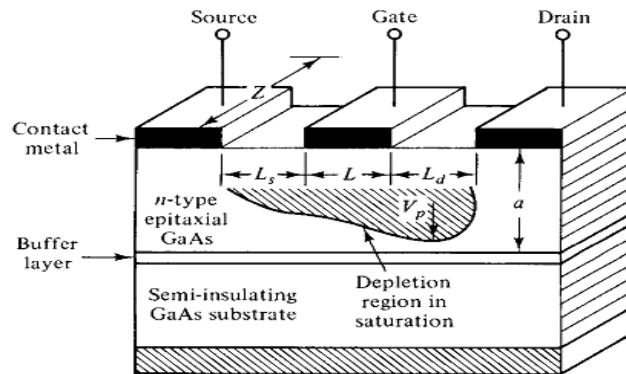

Fig Schematic diagram of a GaAs MESFET.

- In many cases a high resistivity GaAs epitaxial layer, called the buffer layer, is grown between the n-type GaAs layer and the substrate. The photolithographic process may be used to define the patterns in the metal layers such as Au-Ge for source and drain ohmic contacts and in the Al layer for the Schottky barrier-gate contact.
- The reason for using GaAs instead of Si is that GaAs has higher electron mobility and can operate at higher temperature and higher power.

Principles of Operation

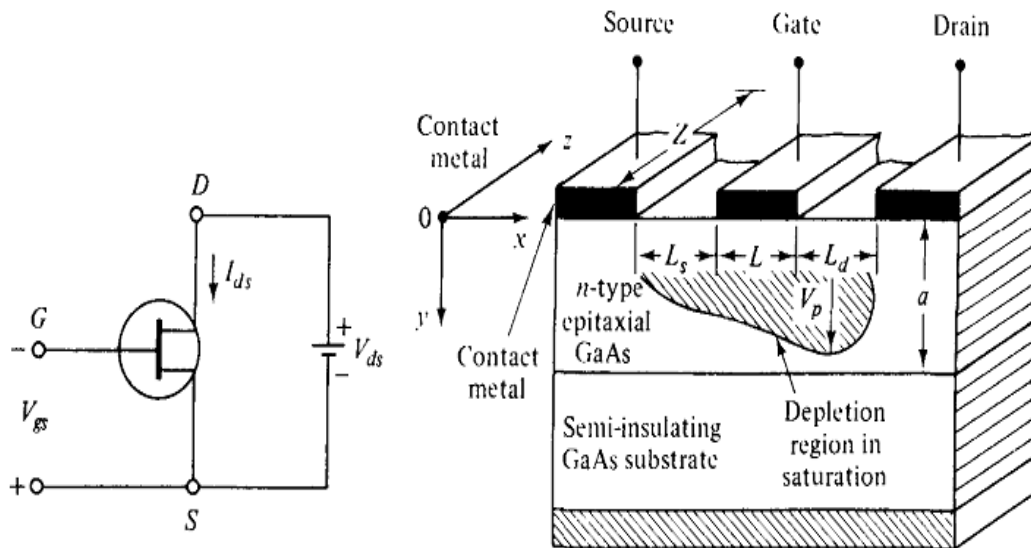

Fig: Schematic diagram and circuit symbol of a GaAs MESFET.

- a voltage is applied in the direction to reverse-bias the p-n junction between the source and the gate, while the source and the drain electrodes are forward-biased.
- Under this bias condition, the majority carriers (electrons) flow in then-type epitaxial layer from the source electrode, through the channel beneath the gate, to the drain

electrode. The current in the channel causes a voltage drop along its length so that the Schottky barrier-gate electrode becomes progressively more reverse-biased toward the drain electrode.

- As a result, a charge-depletion region is set up in the channel and gradually pinches off the channel against the semi-insulating substrate toward the drain end. As the reverse bias between the source and the gate increases,
- So does the height of the charge-depletion region. The decrease of the channel height in the nonpinched-off region will increase the channel resistance.
- Consequently, the drain current I_d will be modulated by the gate voltage V_R .
- This phenomenon is analogous to the characteristics of the collector current I_c versus the collector voltage V_c with the base current as a parameter in a bipolar transistor.
- In other words, a family of curves of the drain current I_d versus the voltage V_d , between the source and drain with the gate voltage V_R as a parameter will be generated in an unipolar GaAs MESFET,

The trans-conductance of a field-effect transistor (FET) is expressed as

$$g_m = \left. \frac{dI_d}{dV_g} \right|_{V_d = \text{constant}} \quad \text{mhos}$$

Pinch-off voltage V_p . The pinch-off voltage is the gate reverse voltage that removes all the free charge from the channel. Poisson's equation for the voltage in the n channel, in terms of the volume charge density is given by

$$\frac{d^2V}{dy^2} = -\frac{\rho}{\epsilon_s} = -\frac{qN_d}{\epsilon_s} = -\frac{qN_d}{\epsilon_r \epsilon_0}$$

where ρ = volume charge density in coulombs per cubic meter

q = charge in coulombs

N_d = electron concentration in electrons per cubic meter

ϵ_s = permittivity of the material in farads per meter

$\epsilon_r = \epsilon_r \epsilon_0$, ϵ_r is the relative dielectric constant

$\epsilon_0 = 8.854 \times 10^{-12}$ F/m is the permittivity of free space

Two cavity klystron amplifier:

The two cavity reflex klystron is a widely used microwave amplifier operated by the principle of velocity modulation and current modulation

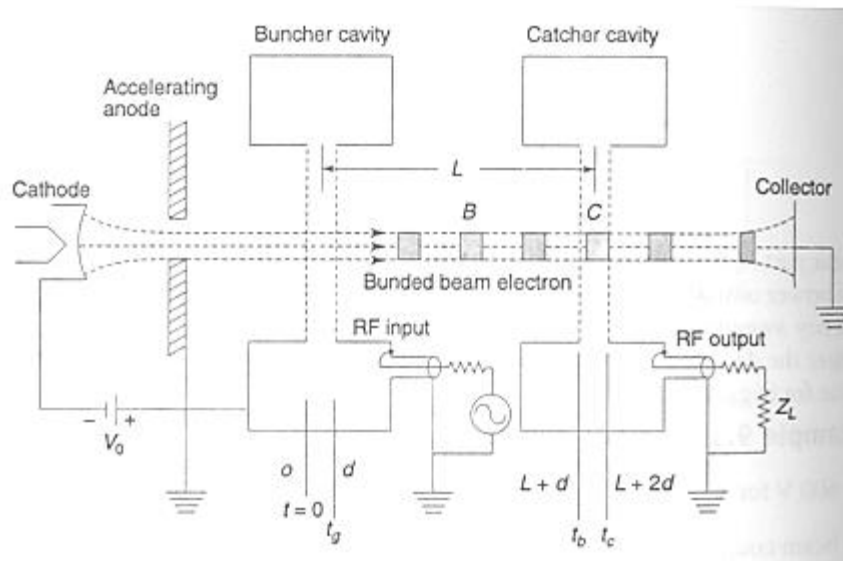
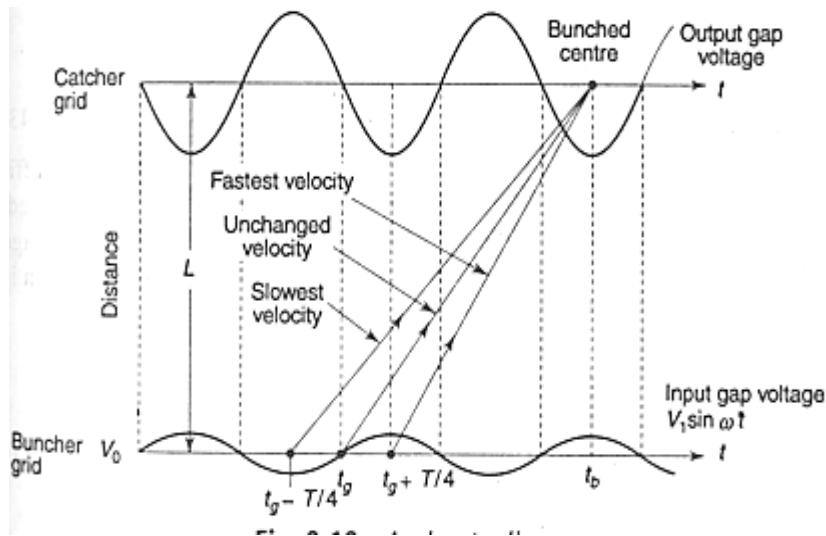

Fig.: Schematic diagram of two cavity Reflex klystron oscillator

Mechanism of operation

1. All the electrons injected from the cathode arrive at the first cavity with uniform velocity. These electrons passing at the cavity gap at zeros of the gap voltage (or) signal voltage pass through unchanged velocity.
2. Those passing through the positive half cycles of the gap voltage undergo an increase in the velocity.
3. Those passing through the negative swings of the gap voltage undergo a decrease in velocity. As the result of these actions, the electrons gradually bunch together as they travel down the drift space is known as velocity modulation.
4. The electron beam modulated to form bunches (or) undergoes density modulation in accordance with the input RF cycle.
5. While passing through the catches cavity grid, this density modulated electron beam induces RF current in the output cavity and thereby excite the RF field in the output cavity at input signal cycle.
6. The phase of field in the output cavity is opposite to that of the input cavity so that the bunched electrons are retarded by the output gap voltage. The loss of kinetic energy of the electrons on retardation process transfers RF energy to the output cavity continuously at signal.



- The electrons then emerge from the second cavity with reduced velocity and finally terminate at the collector.
- The characteristics of a two cavity klystron amplifier are as follows:

Efficiency - about 40%

Power Output –

- The average power (CW power) is upto 500 KW at 10 GHz.
- The pulsed power is upto 30 MW at 10 GHz

Power Gain = about 30 dB.

Velocity Modulation

- When the electrons are first accelerated by the high DC voltage V_0 before entering the buncher grids. Their velocity is uniform.

$$u_0 = \sqrt{\frac{2eV_0}{m}} = 5.93 \times 10^5 \sqrt{V_0} \text{ms}^{-1} \quad \text{----- (1)}$$

- Let the signal voltage across the gap be $V_1 \sin \omega t$.
- Let t_1 = Time taken by the electron beam to enter the buncher cavity (or) the input cavity with velocity V_0 .
- t_2 = Time taken by the electron beam to pass out from the buncher cavity.
- The transit time and transit angle through the transit gap is

$$t_g = \frac{d}{u_0} \quad \text{----- (2)}$$

Transit angle,

$$\omega t_g = \theta_g \quad \text{-----(3)}$$

- Due to input RF signal in the buncher cavity, the average RF voltage in the buncher gap can be obtained as,

$$\begin{aligned}
 V_{av} &= \frac{1}{t_g} \int_{t_1}^{t_2} V_1 \sin \omega t \, dt \\
 &= \frac{V_1}{\theta_g} \left[\frac{-\cos \omega t}{\omega} \right]_{t_1}^{t_2} \\
 &= \frac{V_1(-\cos \omega t_2 + \cos \omega t_1)}{\theta_g} \\
 \therefore V_{av} &= \frac{V_1 \cos \omega t_1 - V_1 \cos \omega t_2}{\theta_g} \quad \text{----- (4)}
 \end{aligned}$$

Let

$$A = \omega t_1 + \frac{\theta_g}{2}$$

$$B = \frac{\theta_g}{2}$$

Also, $A+B = \omega t_1 + \theta_g$

$$A-B = \omega t_1$$

We know that,

$$\omega t_g = \theta_g$$

$$\omega(t_2 - t_1) = \theta_g$$

$$\omega t_2 = \theta_g + \omega t_1$$

$$\begin{aligned}
 V_{av} &= \frac{V_1}{\theta_g} [\cos \omega t_1 - \cos \omega t_2] \\
 V_{av} &= \frac{V_1}{\theta_g} [\cos \omega t_1 - \cos(\theta_g + \omega t_1)]
 \end{aligned}$$





Obtained by (A-B)

Obtained by (A+B)

$$V_{av} = \frac{V_1}{\theta_g} [\cos(A - B) - \cos(A + B)]$$

We know that,

$$\cos(A - B) - \cos(A + B) = 2 \sin A \sin B$$

Equation (4) can be rewritten as,

$$V_{av} = \frac{V_1}{\theta_g} \left[2 \sin \left(\omega t_1 + \frac{\theta_g}{2} \right) \sin \frac{\theta_g}{2} \right]$$

$$V_{av} = V_1 \sin \left(\omega t_1 + \frac{\theta_g}{2} \right) \frac{\sin \frac{\theta_g}{2}}{\frac{\theta_g}{2}}$$

$$V_{av} = V_1 \beta_1 \sin \left(\omega t_1 + \frac{\theta_g}{2} \right) \quad \text{----- (5)}$$

where $\beta_1 = \sin \frac{\theta_g}{2} =$ beam coupling co-efficient of buncher cavity gap

We know that,

$$\omega t_2 = \theta_g + \omega t_1$$

$$\omega t_1 = \omega t_2 - \theta_g$$

From (5),

$$V_{av} = V_1 \beta_1 \sin\left(\omega t_2 - \theta_g + \frac{\theta_g}{2}\right)$$

$$V_{av} = V_1 \beta_1 \sin\left(\omega t_2 - \frac{\theta_g}{2}\right) \text{ ----- (6)}$$

The exit velocity from buncher gap is given by,

$$u(t_2) = \sqrt{\frac{2e(V_0 + V_{av})}{m}} \text{ ----- (7)}$$

$$= \sqrt{\frac{2eV_0\left(1 + \frac{V_1 \beta_1}{V_0} \sin\left(\omega t_2 - \frac{\theta_g}{2}\right)\right)}{m}}$$

The factor $\frac{V_1 \beta_1}{V_0}$ is known as depth of modulation.

If the modulation amplitude is very small ($\ll 1$), then

$$u(t_2) \cong u_0 \left(1 + \frac{V_1 \beta_1}{2V_0} \sin\left(\omega t_2 - \frac{\theta_g}{2}\right)\right) \text{ ----- (8)}$$

The factor $\frac{V_1 \beta_1}{V_0}$ is represented as m.

$$u(t_2) \cong u_0 \left(1 + \frac{m}{2} \sin\left(\omega t_2 - \frac{\theta_g}{2}\right)\right) \text{ ----- (9)}$$

Transit Time in Drift Space

If t_3 is the time when the bunched electrons are at the catcher grid after travelling through the field free drift space.

$$t_3 = t_2 + \frac{L}{u(t_2)} \text{ ----- (10)}$$

$$= t_2 + \frac{L}{u_0 \left(1 + \frac{m}{2} \sin\left(\omega t_2 - \frac{\theta_g}{2}\right)\right)}$$

Let $t_0 = \frac{L}{u_0}$ be the transit time of the reference electron.

$$t_3 = t_2 + t_0 \left(1 + \frac{m}{2} \sin\left(\omega t_2 - \frac{\theta_g}{2}\right)\right)^{-1}$$

We know that,

$$(1+x)^{-1} = 1 - x + x^2 - \dots$$

Neglecting the higher order terms we get,

$$t_3 = t_2 + t_0 \left(1 - \frac{m}{2} \sin\left(\omega t_2 - \frac{\theta_g}{2}\right)\right) \text{ ----- (11)}$$

Density modulation

Because of the difference in velocities of electrons in the velocity modulated beam, the electron will form bunches i.e., becomes density modulated, in accordance with input cycle. A maximum degree of bunching takes place when the buncher and catcher cavities are spaced to satisfy the condition,

$$t_d = t_3 - t_2 = \frac{L}{u(t_2)}$$

From (11),

$$t_d = t_3 - t_2 = t_0 \left(1 - \frac{m}{2} \sin\left(\omega t_2 - \frac{\theta_g}{2}\right)\right) \text{ ----- (12)}$$

The corresponding transit angle in the drift space L is,

$$\begin{aligned}\omega t_d &= \omega(t_3 - t_2) && \text{(From equation (12))} \\ &= \omega t_0 \left(1 - \frac{m}{2} \sin\left(\omega t_2 - \frac{\theta_g}{2}\right)\right) \\ \omega t_d &= \theta_0 - \frac{m\theta_0}{2} \sin\left(\omega t_2 - \frac{\theta_g}{2}\right) && \text{----- (13)}\end{aligned}$$

where, $\theta_0 = \omega t_0 = \text{DC transit angle}$

The transit time of reference electron in terms of N is given by,

$$t_0 = \frac{L}{u_0} = NT$$

Where N = number of RF cycles that are elapsed during the transit time of reference electron.

$$\begin{aligned}\text{Now,} \quad \omega t_0 &= \omega NT = 2\pi f(N) \left(\frac{1}{f}\right) \\ \theta_0 &= \omega t_0 = 2\pi N && \text{----- (14)}\end{aligned}$$

Using equation (14), equation (11) can be rewritten as,

$$\begin{aligned}t_3 &= t_2 + t_0 \left(1 - \frac{m}{2} \sin\left(\omega t_2 - \frac{\theta_g}{2}\right)\right) \\ t_3 &= t_2 + \frac{2\pi N}{\omega} \left(1 - \frac{m}{2} \sin\left(\omega t_2 - \frac{\theta_g}{2}\right)\right) \\ t_3 &= t_2 + \frac{2\pi N}{\omega} - \frac{V_1 \beta_1}{2V_0} \frac{2\pi N}{\omega} \sin\left(\omega t_2 - \frac{\theta_g}{2}\right)\end{aligned}$$

Let X be the bunching parameter and it is given by,

$$\begin{aligned}X &= \frac{\pi N V_1 \beta_1}{V_0} \\ \therefore t_3 &= t_2 + \frac{2\pi N}{\omega} - \frac{X}{\omega} \sin\left(\omega t_2 - \frac{\theta_g}{2}\right) && \text{----- (15)}\end{aligned}$$

Bunched Beam Current: (I_b)

The bunched beam current i_b in the catcher cavity is given by,

$$\begin{aligned}i_b &= \frac{I_0}{\frac{dt_3}{dt_2}} \\ \frac{dt_3}{dt_2} &= 1 - \frac{X}{\omega} \cdot \omega \cdot \cos\left(\omega t_2 - \frac{\theta_g}{2}\right) \\ i_b &= I_0 \left(1 - X \cos\left(\omega t_2 - \frac{\theta_g}{2}\right)\right)^{-1}\end{aligned}$$

By Fourier expansion, the beam current of two cavity reflex klystron is,

$$i_b = I_0 + 2I_0 \sum_{n=1}^{\infty} J_n(nX) \cos n\left(\omega t_2 - \frac{\theta_g}{2}\right)$$

Expanding the summation we get,

$$i_b = \underbrace{\{I_0\}}_{\text{Dc component}} + \underbrace{\{2I_0J_1(X)\cos\left(\omega t_2 - \frac{\theta_g}{2}\right)\}}_{\text{Fundamental Ac Component}} + \underbrace{\{\sum_{n=2}^{\infty} J_n(nX)\cos n\left(\omega t_2 - \frac{\theta_g}{2}\right)\}}_{\text{Harmonics}}$$

The klystron is generally tuned to the fundamental AC component of current and it is given by,

$$i_b = 2I_0J_1(X)\cos\left(\omega t_2 - \frac{\theta_g}{2}\right) \quad \text{----- (16)}$$

Optimum Drift Space Length: L_{opt}

$$t_0 = \frac{L_{opt}}{u_0}$$

$$L_{opt} = u_0 t_0 \quad \text{----- (17)}$$

We know that,

$$X = \frac{\pi N V_1 \beta_1}{V_0} \times \frac{2}{2}$$

$$X = \frac{\omega t_0 V_1 \beta_1}{2V_0}$$

$$t_0 = \frac{2XV_0}{\omega V_1 \beta_1} \quad \text{----- (18)}$$

Substituting eqn.(18) in (17), we get

$$L_{opt} = \frac{2u_0 X V_0}{\omega V_1 \beta_1}$$

From the Bessel function table, $J_1(X)$ is maximum i.e., 0.582 at $X=1.841$

$$L_{opt} = \frac{2u_0(1.841)V_0}{\omega V_1 \beta_1}$$

$$L_{opt} = \frac{3.682u_0V_0}{\omega V_1 \beta_1} \quad \text{----- (19)}$$

Power and efficiency considerations:

Power Output:

The fundamental component of RF beam current passing through the output cavity gap induces a current in the catcher cavity.

$$i_c = \beta_2 |i_b|$$

Where $\beta_2 \rightarrow$ beam coupling coefficient of catcher cavity.

$$i_c = \beta_2 \cdot [2I_0J_1(X)]$$



I_2

Therefore,

$$i_c = \beta_2 I_2$$

If the buncher and catcher cavities are identical, then $\beta_0 = \beta_1 = \beta_2$

$$\therefore i_c = \beta_0 I_2$$

The output power delivered to catcher cavity is,

$$P_{out} = \frac{(\beta_0 I_2)^2 R_{sh}}{2}$$
$$P_{out} = \frac{(\beta_0 I_2) [(\beta_0 I_2) R_{sh}]}{2}$$
$$P_{out} = \frac{(\beta_0 I_2) V_2}{2}$$

Efficiency: η

The electronic efficiency of klystron amplifier is defined as the ratio of the output power to the input power.

$$\eta = \frac{P_{out}}{P_{dc} \text{ (or) } P_{in}}$$
$$\eta = \frac{(\beta_0 I_2) V_2}{2 I_0 V_0}$$

If the coupling co-efficient is perfect i.e., $\beta_0 = 1$ and $V_2 = V_0$, then there is maximum beam current in the catcher cavity.

$$\eta = \frac{2 I_0 J_1(X)}{2 I_0}$$
$$\eta = 0.582 \times 100$$
$$\eta = 58.2\%$$

The maximum electronic efficiency of two cavity reflex klystron is **58.2 %**

Reflex Klystron oscillators:

- A reflex Klystron is a low power, low efficiency, microwave oscillator.

Mechanism of Oscillation

1. Due to d.c. voltage in the cavity circuit, RF field is generated in the cavity. The electrons passing through the cavity gap 'd' experience this RF field and are velocity modulated in the following manner.
2. Electrons as shown in fig. below which encountered the positive half cycle of the RF field in the cavity gap 'd' will be accelerated, the electrons at 'b' which encountered zero RF field will pass with unchanged original velocity and the electrons at 'c' which encountered the negative half cycle will be retarded on entering the repeller space.

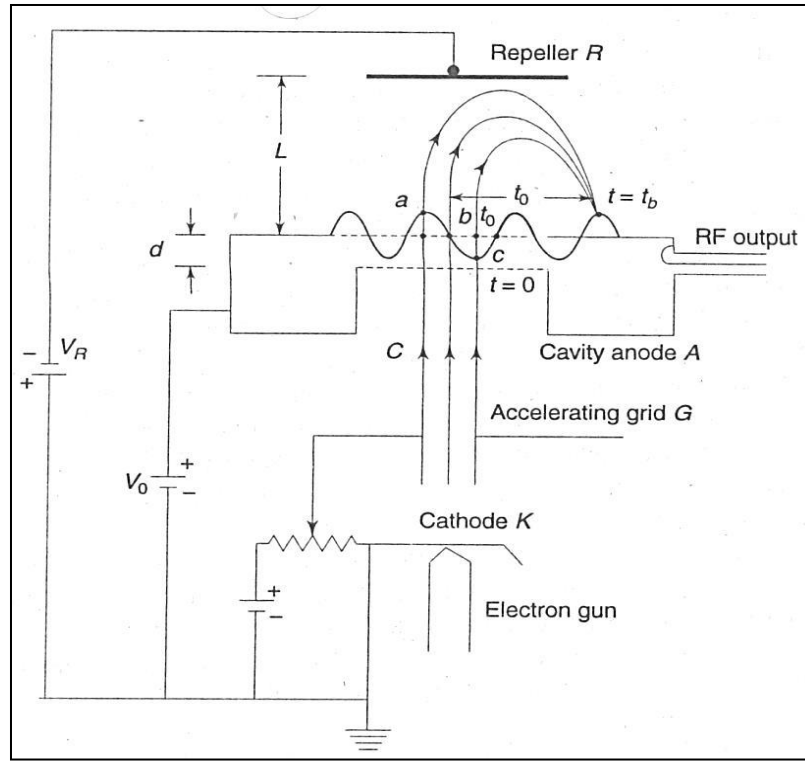

Fig.: Schematic diagram of Reflex klystron oscillator

3. All these velocity modulated electrons will be repelled back to the cavity by the repeller due to its negative potential. Repeller distance L and the voltages can be adjusted to receive all the velocity modulated electrons at the same time on the positive peak of the cavity RF voltage cycle.
4. Thus the velocity modulated electrons are bunched together and lose their kinetic energy when they encounter the positive cycle of the cavity RF field. This loss of energy is thus transferred to the cavity to conserve the total power.
5. If the power delivered by the bunched electrons to the cavity is greater than the power loss in the cavity, the electromagnetic field amplitude at the resonant frequency of the cavity will increase to produce microwave oscillations.

Bunching of Electrons

- The reference electron is taken as one that passes the gap on its way to the repeller at the time when the gap voltage is zero and going negative. This electron overshoots the gap and return to it with some distance penetrated into the repeller.
- An electron passing the gap slightly earlier will have slightly positive voltage at the gap. The resulting acceleration would have propelled this electron slightly farther into the repeller space, and the electron would have taken slightly longer time than reference electron to return to the gap.
- Similarly electron passing after reference electron will have slightly negative voltage. Thus bunching of electrons takes place.

Applegate Diagram

Applegate diagram of Reflex Klystron is shown in figure below:

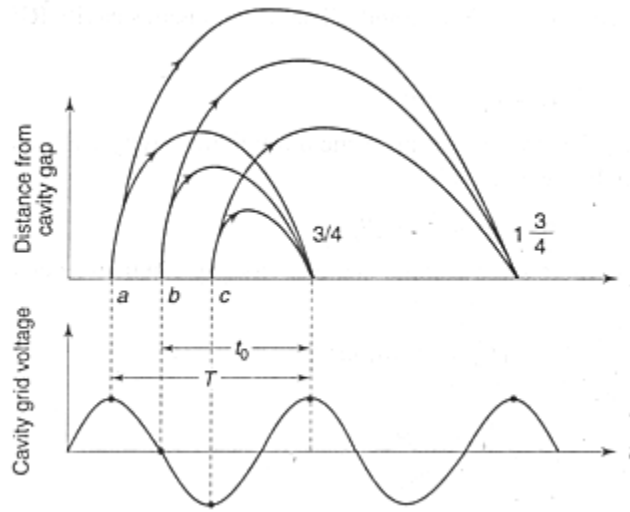

Fig.: Applegate diagram of Reflex Klystron

- When the gap voltage is at positive peak, electron passing at this moment is called **early electron** (e_e). This electron is accelerated towards repeller and travels a distance, which is longer comparatively. The electron at natural zero of gap voltage is called **reference electron** (e_R). When the gap voltage is at negative peak the corresponding electron is called **late electron** (e_L).
- The late electron is decelerated and travels less distance. Thus, e_e , e_R , e_L of different velocities cover different forms bunch at cavity gap. Thus oscillations build up.

Modes and efficiency considerations:

Modes of oscillations

- **The condition for oscillation**
 $t_0 = (n + \frac{3}{4})T = NT$
 $N = n + \frac{3}{4}$, $n = 0, 1, 2, \dots$
Where, $N = n + \frac{3}{4}$ and $n = 0, 1, 2, 3, \dots$

Relation between Repeller Voltage and Accelerating Voltage

$$\frac{V_0}{(V_R - V_0)^2} = \frac{1}{8} \cdot \frac{1}{\omega^2 L^2} \cdot \frac{e}{m} \cdot \left(2\pi n - \frac{\pi}{2}\right)^2$$

Where, V_0 - anode voltage

V_R - repeller voltage

L - Distance between cavity gap and repeller electrode.

Output Power

$$P_{out} = \frac{2V_o I_o X' J_1(X')}{\omega L} \cdot (V_R - V_o) \cdot \sqrt{\frac{e}{2mV_o}}$$

$$P_{out} \text{ or } P_{RF} = \frac{0.3986 V_o I_o}{N}$$

Efficiency of Reflex Klystron

$$\eta = \frac{2X' J_1(X')}{\left(2\pi n - \frac{\pi}{2}\right)} \text{ or } \eta = \frac{0.3986}{N}$$

Where, $J_1(X)$ is Bessel function of 1st order for argument X.

The factor $X' J_1(X')$ reaches maximum value of 1.252 at $X' = 2.408$ and $J_1(X') = 0.52$.

Applications of Reflex Klystron

- Pump oscillator for parametric amplifiers.
- Frequency modulated oscillator portable microwave links
- Local oscillator in microwave receivers
- Signal source in microwave generators

Cylindrical Magnetrons and Helix TWT:

- A magnetron oscillator is used to generate high microwave power. Magnetrons are cross field tubes in which the dc magnetic field and dc electric field are perpendicular to each other.
- The cathode is a rod in the center of the tube and anode is a solid block. The anode contains several resonant cavities. The space between cathode and anode is known as interaction space.

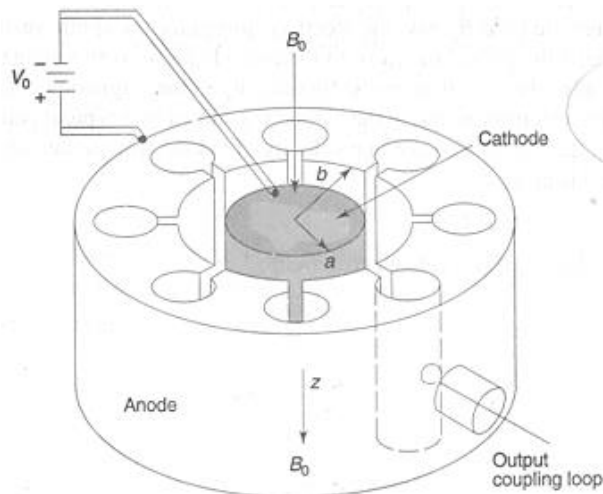



Fig. Magnetron

- Radial electric field is established by dc voltage V_0 in between cathode and anode and dc magnetic flux denoted by β_0 is maintained in positive Z-direction by means of a permanent (or) electromagnet.

- There are three forces acting on an electron in the interaction region of the magnetron,
 - ✓ force due to electric field ($-\mathbf{eE}$)
 - ✓ force due to magnetic field [$-\mathbf{e} (\mathbf{V} \times \mathbf{B})$]
 - ✓ centrifugal force ($\frac{mv^2}{r}$)
- The electrons emitted from the cathode try to travel towards anode.
- At zero magnetic field, the electron takes the straight path **a** by the influence of electric field only.
- For a given V_0 , if the magnetic field is increased, the electrons take curved path **b** to reach the anode.
- At a critical value of magnetic field B_c , the electrons just graze the anode surface and return to the cathode for a given voltage V_0 . The value B_c is called the cut-off magnetic flux density.
- If the magnetic field is greater than B_c , all the electrons return to the cathode by a typical path X without reaching the anode.

At the equilibrium condition,

$$\frac{mv^2}{r} + eE = eVB \quad \text{----- (1)}$$



CENTRIFUGAL FORCE



FORCE DUE TO ELECTRONS



MAGNETIC FIELD

The electric field E is a function of radial direction only and is given by

$$E(r) = -\frac{V_0}{r \ln\left(\frac{b}{a}\right)} \quad \text{----- (2)}$$

Where **a** and **b** are the anode and cathode radius respectively.

In the absence of electric field, the electrons move in a circular path and return to the cathode, then

$$\frac{mv^2}{r} = eVB$$

$$\frac{V}{r} = \frac{eB}{m} = \omega \quad \text{----- (3)}$$

Where ω is called the cyclotron angular frequency

The equation of motion for electrons in magnetic field in cylindrical co-ordinates is given by,

$$\frac{1}{r} \frac{d}{dt} \left(r^2 \frac{d\phi}{dt} \right) = \frac{eB}{m} \frac{dr}{dt} \quad \text{----- (4)}$$

$$\frac{d}{dt} \left(r^2 \frac{d\phi}{dt} \right) = \frac{eB}{m} (r) \frac{dr}{dt}$$

We know that,

$$\frac{d}{dt} (r^2) = 2r \frac{dr}{dt}$$

$$\therefore r \frac{dr}{dt} = \frac{1}{2} \frac{dr^2}{dt}$$

So,

$$\frac{d}{dt} \left(r^2 \frac{d\phi}{dt} \right) = \frac{1}{2} \frac{eB}{m} \frac{dr^2}{dt}$$

From equation (3), $\frac{eB}{m} = \omega$. So we get,

$$\frac{d}{dt} \left(r^2 \frac{d\phi}{dt} \right) = \frac{\omega}{2} \frac{dr^2}{dt}$$

Integrating on both sides we get,

$$r^2 \frac{d\phi}{dt} = \frac{\omega r^2}{2} + k \quad \text{----- (5)}$$

Where k = integration constant.

Let **a** be the radius of the cathode cylinder .

At $r=a$ and $\frac{d\phi}{dt} = 0$, then the constant **k** is given by

$$k = -\frac{1}{2} \omega a^2 \quad \text{----- (6)}$$

Substitute (6) in (5),

$$\begin{aligned} r^2 \frac{d\phi}{dt} &= \frac{\omega r^2}{2} - \frac{1}{2} \omega a^2 \\ \frac{d\phi}{dt} &= \frac{\omega}{2} \left(1 - \frac{a^2}{r^2} \right) \quad \text{----- (7)} \end{aligned}$$

This expression gives the angular velocity of electron.

The kinetic energy of electron is given by,

$$\begin{aligned} \frac{mv^2}{2} &= eV \\ v^2 &= \frac{2eV}{m} \quad \text{----- (8)} \end{aligned}$$

However, the electron velocity has **r** and ϕ components such as,

$$\begin{aligned} v^2 &= v_r^2 + v_\phi^2 \\ v^2 &= \left(\frac{dr}{dt} \right)^2 + \left(r \frac{d\phi}{dt} \right)^2 \quad \text{----- (9)} \end{aligned}$$

Let **b** be the radius from the centre of the cathode to the edge of the anode.

At $r=b$, $\mathbf{V} = \mathbf{V}_0$, $\frac{dr}{dt} = 0$, the electron just grazes the anode.

$$v_0^2 = b^2 \left(\frac{d\phi}{dt} \right)^2 \quad \text{----- (10)}$$

From equation (8),

$$v_0^2 = \frac{2eV_0}{m} \quad \text{----- (11)}$$

Comparing (10) and (11),

$$\begin{aligned} \frac{2eV_0}{m} &= b^2 \left(\frac{d\phi}{dt} \right)^2 \\ \frac{2eV_0}{m} &= b^2 \left(\frac{\omega}{2} \left(1 - \frac{a^2}{b^2} \right) \right)^2 \quad \text{----- (12)} \end{aligned}$$

Substituting $\frac{eB}{m} = \omega$,

$$\frac{2eV_0}{m} = b^2 \left[\frac{eB}{2m} \left(1 - \frac{a^2}{b^2} \right) \right]^2$$

$$\frac{2eV_0}{m} = b^2 \frac{(eB)^2}{4m^2} \left(1 - \frac{a^2}{b^2} \right)^2$$

$$\frac{8m^2 eV_0}{m} = b^2 (eB)^2 \left(1 - \frac{a^2}{b^2} \right)^2$$

$$\frac{8meV_0}{e^2 b^2 \left(1 - \frac{a^2}{b^2} \right)^2} = B^2$$

$$B^2 = \frac{8V_0 \left(\frac{m}{e} \right)}{b^2 \left(1 - \frac{a^2}{b^2} \right)^2}$$

At the critical magnetic field, $B_c = B$

$$B_c = \frac{\left(8V_0 \frac{m}{e} \right)^{\frac{1}{2}}}{b \left(1 - \frac{a^2}{b^2} \right)} \quad \text{----- (13)}$$

Thus if applied magnetic field B is greater than B_c for a given V_0 , the electron will not reach the anode.

For a given B_0 , the cut off voltage is given by,

$$V_c^2 = \frac{e}{8} m b^2 \left(1 - \frac{a^2}{b^2} \right)^2 B^2 \quad \text{----- (14)}$$

If $V_0 < V_c$, for a given B , the electron will not reach the anode. Equations(3)and(14) for B_c and V_c called Hull- cut off magnetic and voltage equation, respectively.

RF Structure of Magnetron:

- Magnetron structure supports varieties of modes depending upon the phase difference between fields in two adjacent cavities.
- Boundary conditions are satisfied when total phase shift around the 8 cavities is a multiple of 2π radians.
- The phase shift between the fields of adjacent cavities is π radians. This is known as π mode. Magnetron oscillators operated in π mode. [$\phi_n = \pi$ mode]
- Frequency of π –mode can be easily separated from adjacent modes by incorporating conducting straps connected to alternate segment of anode block.

Mechanism of oscillations

- The electron beams a come across an electric field in the direction of its velocity. It is retarded by the field, slow down and drifts towards the anode values of the static E and H fields are so adjusted that the time the electron reaches near the second cavity.
- Last a time period elapses, The electron experiences a retarding field again and loses energy to the RF field. This process continues the transfer of energy takes place again near the third cavity.

Phase Focusing Effect:

- Π – Mode oscillations of cavity magnetron causes electron to bunch, and this effect is

called as phase focusing effect.

- Without this effect electrons would fall behind the phase change of the electric field across the gaps, since such electrons are retarded at each interaction with RF field.
- The bunches rotate counter clockwise with correct velocity to keep up with RF phase changes between adjoining a mode poles. Thus continued interchange of energy takes place, with RF field

Applications:

- RADAR transmitters
- Microwave ovens
- Industrial heating
- In oscillators with great power and pulsed operation at 100 GHz and greater.

Helix TWT:

- The travelling wave tube is an amplifier which makes use of a distributed interaction between an electron beam and a travelling wave.
- The travelling wave tube (TWT) is an O-type parallel field, linear beam device, but it differs from the Klystron in that the RF field and the electron beam interact with each other over the entire length of the active region, instead of only at the cavity gaps.
- Although TWTs exist that use resonant cavities, most TWTs are non-resonant devices and hence have wider bandwidths than Klystrons.

Construction

- The TWT contains an electron gun, which produces and then accelerates an electron beam along the axis of the tube.
- The surrounding static magnet provides a magnetic field along the axis of the tube. The focus the electrons into a tight beam.
- A longitudinal helix slow wave non-resonant guide is placed at the center of the tube.
- The RF input and output are coupled into and removed from the helix by directional couplers that have no physical connection to the helix.
- The TWT is designed with helix delay structure to slow the travelling wave down to or below the speed of the electrons in the beam.
- The electrons of the beam are accelerated to travel faster than the waves travelling on the helix wire through the velocity modulation caused by the interaction between the travelling wave fields and the electron beam.
- This effect results in bunching and the electrons give up energy to the travelling wave when the fields of the correct polarity slow down the bunches.

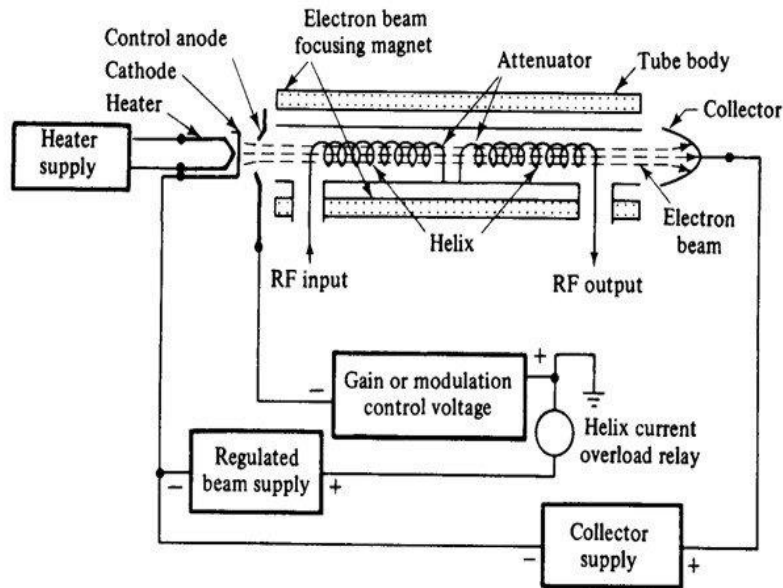

Fig; TWT Tube and Circuit

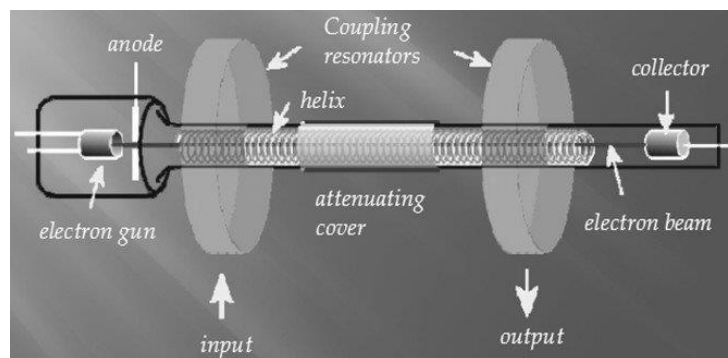

- The energy from the bunches increase the amplitude of the travelling wave in a progressive action that takes place all along the length of the TWT.
- The RF signal injected at the input end of the helix travels down the helix wire at the speed of light, but the coiled shape causes the wave to travel a much greater total distance than the electron beam.
- Changing the number of turns in the helix wire, the speed at which the RF signal wave travels in the form of axial E field down the tube, can be varied.
- DC beam voltage is adjusted so that beam velocity is slightly greater than that of the axial field. The helical delay structure has the added advantage of causing a large portion of electric fields that are parallel to the electron beam provides maximum interaction between the fields and the electron beam to form bunching.
- As the electron bunches release energy to the signal on the helix, amplification begins.

The initial amplified signal causes the denser electron bunch which in turn, amplifies the signal even more. This process continues as the RF wave and the electron beam travel down the length of the tube. When the loss in the system is compensated by this energy transfer, a steady amplification of the microwave signal appears at the output end.

- An attenuator is placed over a part of the helix on midway to attenuate and reflected waves generated due to impedance mismatch that could be fed back to the input to cause oscillations.
- The attenuator is placed after sufficient length of the interaction region so that the attenuation of the amplified signal is insignificant compared to the amplification.
- The internal attenuator reduces the gain of the tube. The TWT also produces heat which must be dissipated by either air-conditioning or liquid-cooling systems.

Analysis of TWT

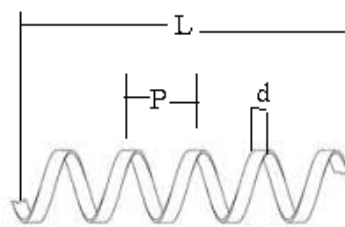

- If d is the diameter of the helix and p is the pitch, the time taken by signal along the wire must be equal to that taken by the axial wave, so that

$$T = \frac{p}{vp} = \frac{\sqrt{p^2 + (\pi d)^2}}{c}$$

$$vp = \frac{cp}{\sqrt{p^2 + (\pi d)^2}} = \frac{cp}{\pi d} = \frac{\omega}{\beta}$$

Gain in TWT

- The gain in TWT is proportional to the length of the slow wave structure and is found from

$$Gain(dB) = \left[\frac{47.3 FL^3}{2\pi V_0} \sqrt{\frac{1K}{4V}} \right] - 9.54$$

Where, F – RF frequency in hertz

V_0 – Electron Velocity

K – Helix impedance in ohms

V – applied dc voltage

I - Dc current

Applications of TWT

- Low noise tubes are used in RF amplifiers in broadband microwave receivers.
- Medium and high power satellite transponder output.
- CW radar and radar jamming

UNIT-II S Parameters:

Scattering parameters:

Scattering parameters or S-parameters (the elements of a scattering matrix or **S**-matrix) describe the electrical behavior of linear electrical networks when undergoing various steady state stimuli by electrical signals.

properties of S matrix:

1.) Zero diagonal element for perfect matched network

For an ideal N-port matched network with matched termination at all ports, $S_{ii}=0$, since there is no reflection from any port. Therefore, under perfect matched conditions, the diagonal elements of [S] are zero.

2.) Symmetry of [S] For a Reciprocal Network

A reciprocal device has the same transmission characteristics in either direction of a pair of ports and is characterized by a symmetric scattering matrix

$$S_{ij}=S_{ji} \quad (i=j)$$

Which results $[S^t] = [S]$. This property is known as symmetry property of S-matrix.

Proof

The impedance Z of a network is given by

$$[V] = [Z][I] \quad \text{-----(1)}$$

The average power flowing in to the port n may be evaluated using the following relation

$$a_n = V_{n+} / \sqrt{Z_0} \text{-----(2)}$$

$$b_n = V_{n-} / \sqrt{Z_0} \text{-----(3)}$$

Where, V_{n+} = incident

V_{n-} = outgoing wave

Using above relation V_n and I_n can be written as

$$V_n = (V_{n+}) + (V_{n-}) = \sqrt{Z_0}(a_n + b_n) \quad \text{----- (4)}$$

$$I_n = \{(V_{n+}) - (V_{n-})\} / Z_0 = (a_n - b_n) / Z_0 \quad \text{----- (5)}$$

Subs eqn (4) & (5) in eqn (1)

$$[V+] + [V-] = [Z] (1/Z_0) ([V+] - [V-]) \quad \text{----- (6)}$$

$$= [Z_1] ([V+] - [V-]) \quad \text{----- (7)}$$

Where, $Z_1 = [Z] / Z_0$

Equation (6) can be written as

$$\{([Z_1] + [U]) [V-]\} = \{([Z_1] - [U]) [V+]\}$$

Since $(Z_1 + U)(V_-) = (Z_1 - U)(V_+)$

Where, $[U]$ is the unity matrix.

$$\begin{aligned} [V_-] &= [V_+] \{ ([Z_1] - [U]) / ([Z_1] + [U]) \} \\ [V_-] &= ([Z_1] - [U]) \{ 1 / ([Z_1] + [U]) \} [V_+] \\ [V_-] &= [S] [V_+] \end{aligned} \quad \text{-----(8)}$$

Where,

$$[S] = ([Z_1] - [U]) \{ 1 / ([Z_1] + [U]) \}$$

Writing transpose of $[S]$,

$$[S^t] = ([Z_1] - [U])^t \{ 1 / ([Z_1] + [U])^t \}$$

As $[Z_1]$ and $[U]$ are symmetrical matrixes,

$$\begin{aligned} \{ 1 / ([Z_1] + [U]) \}^t &= 1 / ([Z_1] + [U]) \\ ([Z_1] - [U])^t &= ([Z_1] - [U]) \\ \text{Hence} \quad [S] &= [S^t]. \end{aligned}$$

This indicates that scattering matrix $[S]$ is SYMMETRICAL.

(3.) Unitary Property for a Lossless Junction

For any lossless network the sum of the products of each term of any one row or of any column of the S matrix multiplied by its complex conjugate

For lossless n port device, the total power rating

N port must be equal to the total power input to these ports. The mathematical statement for this power conservation condition is,

$$\sum_{n=1}^N |b_n|^2 = \sum_{n=1}^N |a_n|^2 \quad \text{----- (1)}$$

The relationship between b_n and a_n for two port network may be return as

$$[b] = [S] [a]$$

$$\text{Using above relations } b_n = \sum_{i=1}^n (S_{ni} a_i) \quad \text{-----(2)}$$

sub (2) in (1)

$$\sum_{i=1}^N \left| \sum_{n=1}^N S_{ni} a_i \right|^2 = \sum_{n=1}^N |a_n|^2$$

If only 1 the port is executed and all other ports are matched terminated, all $a_n=0$ except a_i , so that,

$$\begin{aligned} \sum_{n=1}^N |S_{ni} a_i|^2 &= \sum_{n=1}^N |a_n|^2 \\ \sum_{n=1}^N |S_{ni}|^2 &= 1 \end{aligned}$$

$$\text{ie } \sum_{n=1}^N S_{ni} S_{ni}^* = 1$$

The above equation states that for a lossless network the product of any column of the scattering matrix with the conjugate of this column equals UNITY. If all $a_n=0$ except a_i & a_k

$$\sum_{n=1}^N S_{nk} \cdot S_{ni}^* = 0; \text{ for } i \neq k$$

This equation states that the product of any column of the scattering matrix with the complex conjugate of any other column is zero. In matrix notation, the relations are expressed as

$$[S^*] [S] = [U]$$

$$[S^*] = [S]^{-1}$$

[U] = Unit matrix. A matrix [S] for lossless network which satisfies the above three conditions is called unitary matrix.

Shifting of reference planes in two port network

(a.) Phase shift property:-

Complex S-parameters of a network are defined with respect to the position of the port (or) reference planes. For a two port network with unprimed reference planes 1 and 2

$$\begin{pmatrix} b_1 \\ a_1 \end{pmatrix} = \begin{pmatrix} S_{11} & S_{12} \\ S_{21} & S_{22} \end{pmatrix} \cdot \begin{pmatrix} a_1 \\ a_2 \end{pmatrix}$$

Where a_1, a_2 are incident waves & b_1, b_2 are outgoing waves

S-matrix for any network when the reference plane for one of its ports is shifted away along the transmission line is given by (in fig, shifted reference is mentioned as 1^2 and 2^1)

$$\begin{pmatrix} b_1 \\ b_2 \end{pmatrix} = \begin{pmatrix} 0 & e^{-j\beta l_1} \\ e^{-j\beta l_2} & 0 \end{pmatrix} \cdot \begin{pmatrix} a_1 \\ a_2 \end{pmatrix} \quad (\text{for lossless network})$$

$$\begin{pmatrix} b_1 \\ b_2 \end{pmatrix} = \begin{pmatrix} 0 & e^{-j\phi_1} \\ e^{-j\phi_2} & 0 \end{pmatrix} \cdot \begin{pmatrix} a_1 \\ a_2 \end{pmatrix}$$

Where, l_1, l_2 = path length.

β_1, β_2 = phase constant.

This property is valid for any number of ports and is called the phase shift property applicable to shift of reference planes. The resultant S^1 MATRIX is

$$(S^1) = \begin{pmatrix} e^{-j\phi_1} & 0 \\ 0 & e^{-j\phi_2} \end{pmatrix} \cdot (S) \cdot \begin{pmatrix} e^{-j\phi_1} & 0 \\ 0 & e^{-j\phi_2} \end{pmatrix}$$

(4.) Zero property of S matrix

The sum of products of each term of any column (or row) multiplied by the complex conjugate of the corresponding terms of any other column(or row) as zero and as

$$S_{11} S_{12}^* + S_{21} S_{22}^* = 0$$

$$b_1 = S_{11} a_1 + S_{12} a_2$$

$$b_2 = S_{21} a_1 + S_{22} a_2$$

Wave guide Tee:

The waveguide tees are 3 port components and are mainly of two types E-plane tee connected in series and H-plane tee connected in shunt with section or branch of main waveguide transmission line.

- Tees are junctions having three or more ports. Waveguide tees are used for the purpose of connecting a branch section of waveguide in series or parallel with main waveguide.
- There are E or H- plane tees depending on whether they are in the plane of electric field or magnetic field. Because of junctions waveguides tees are poorly matched device. For matching reactance, tuning screws are used.

E-Plane Tee

- All the arms of E-plane tee lie in the plane of electric field which divide among the arms as shown in figure below:

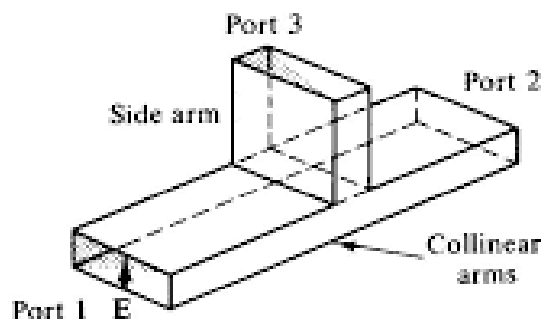

Fig: E- plane Tee

- The E-plane tee is a voltage or series junction. Each junction is symmetrical about the central arm so that the signal to be split up is fed from it.
- The propagation of an E-field through tee junction when electromagnetic waves in TE₁₀ mode.
- Due to the junction's symmetry, the power delivered to port 1 and 2 are the same. Also

the electric fields at the two outputs are 180° out of phase.

- When powers P_1 and P_2 are applied to port 1 and port 2 respectively and if magnitude and phase of P_1 and P_2 are same then power at P_3 is zero.
- Scattering matrix $[S]$ of E-plane tee is 3×3 matrixes since there are 3 ports.

$$[S] = \begin{bmatrix} S_{11} & S_{12} & S_{13} \\ S_{21} & S_{22} & S_{23} \\ S_{31} & S_{32} & S_{33} \end{bmatrix}$$

- When port 3 is perfectly matched $S_{33} = 0$

$$S_{13} = S_{31} = 1/\sqrt{2} \text{ and } S_{23} = S_{32} = -1/\sqrt{2}$$

Therefore, S-matrix is given as

$$[S] = \begin{bmatrix} S_{11} & S_{12} & S_{13} \\ S_{21} & S_{22} & S_{23} \\ S_{31} & S_{32} & S_{33} \end{bmatrix} = \begin{bmatrix} 1/2 & 1/2 & 1/\sqrt{2} \\ 1/2 & 1/2 & -1/\sqrt{2} \\ 1/\sqrt{2} & -1/\sqrt{2} & 0 \end{bmatrix}$$

H-Plane Tee

- H-Plane Tee is so called because the axis of the side arm is parallel to the planes of H-field of the main transmission line. As all three arms of H-plane tee lie in the plane of magnetic field the magnetic field divides itself into the arms, therefore it is a current junction. Figure shows H-plane tee.

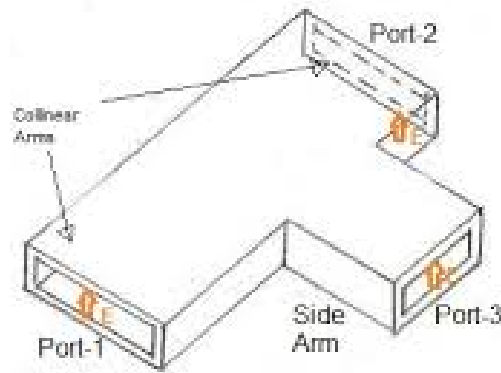

Fig: H-Plane Tee

- If the H-plane junction is completely symmetrical and the electromagnetic wave enters through the side arm, the wave that comes out from main arms are equal in magnitude and phase i.e the input power of port 3 is equally split into ports 1 and 2.
- When the same input powers are applied at ports 1 and 2 the output power at port 3 is sum of input powers.

- Scattering matrix of H-plane Tee is

$$[S] = \begin{bmatrix} S_{11} & S_{12} & S_{13} \\ S_{21} & S_{22} & S_{23} \\ S_{31} & S_{32} & S_{33} \end{bmatrix} = \begin{bmatrix} 1/2 & -1/2 & 1/\sqrt{2} \\ -1/2 & 1/2 & 1/\sqrt{2} \\ 1/\sqrt{2} & 1/\sqrt{2} & 0 \end{bmatrix}$$

Applications of E-plane and H-plane tee

- The E and H plane tees are used for impedance matching purposes. Also these are employed for splitting the power and summing the power.

Hybrid or Magic Tee:

- A magic Tee is a combination of an E-plane and H-plane tee. It acts as a 4-port hybrid circuit. It is also called as Hybrid Tee. Figure below shows magic tee.

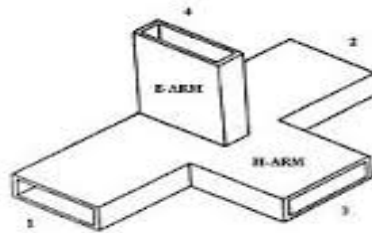

Fig: Magi Tee

Characteristics of magic tee

- If two waves of equal magnitude and the same phase are fed into port-1 and port-2, the output will be zero at port-3 and additive at port-4
- If a wave is fed into port-4, it will be divided equally between port-1 and port-2 of the collinear arms and will not appear at port-3.

$$S_{14} = S_{41} = 1/\sqrt{2} \quad S_{24} = S_{42} = 1/\sqrt{2} \quad \text{and} \quad S_{34} = 0$$

- If a wave is fed into port-3, it will produce an output of equal magnitude and opposite phase at port-1 and port-2. The output at port-4 is zero.

$$S_{13} = S_{31} = 1/\sqrt{2} \quad S_{23} = S_{32} = -1/\sqrt{2} \quad \text{and} \quad S_{34} = 0$$

- If a wave is fed into one of the collinear arms at port-1 or port-2, it will not appear in the other collinear arm at port-2 or port-1 because the E-arm causes a phase delay while the H-arm causes a phase lead.

$$S_{12} = S_{21} = 0$$

- Magic Tee is symmetrical about an imaginary plane bisecting arms port-3 and port-4.
- If port-1 and 2 are terminated in matched loads and no reflections take place inside the junction, entrance of power through either port 3 or 4 results in equal power delivery to arm 1 and 2. Reflections may take place due to severe discontinuities in the junction.

Effects of reflections

1. Only a portion of the power that approaches the junction through port-3 or 4 is delivered to port-1 and 2.
2. Power is not divided equally between port-1 and 2, when power enters through port-3 or 4
3. Balance does not exist between port-1 and 2 i.e some power transmits directly from port-1 to port-2.

$$[S] = \begin{bmatrix} S_{11} & S_{12} & S_{13} & S_{14} \\ S_{21} & S_{22} & S_{23} & S_{24} \\ S_{31} & S_{32} & S_{33} & S_{34} \\ S_{41} & S_{42} & S_{43} & S_{44} \end{bmatrix}$$

But $S_{21} = 0, S_{12} = 0, S_{43} = 0, S_{34} = 0$

$S_{11} = 0, S_{22} = 0, S_{33} = 0, S_{44} = 0$

And $S_{14} = S_{24}, S_{13} = -S_{23}$

For port-3 and port 4 matched

Therefore S-matrix becomes

$$[S] = \begin{bmatrix} 0 & 0 & S_{13} & S_{14} \\ 0 & 0 & -S_{13} & S_{14} \\ S_{31} & S_{32} & 0 & 0 \\ S_{41} & S_{42} & 0 & 0 \end{bmatrix} = \frac{1}{\sqrt{2}} \begin{bmatrix} 0 & 0 & 1 & 1 \\ 0 & 0 & -1 & 1 \\ 1 & -1 & 0 & 0 \\ 1 & 1 & 0 & 0 \end{bmatrix}$$

Applications of magic Tee

1. As an isolator
2. As a matching device
3. As a phase shifter
4. As duplexer
5. As mixer

Hybrid rings (Rat-Race Circuits)

A rat-race coupler (also known as a hybrid ring coupler) is a type of coupler used in RF and Microwave systems. In its simplest form it is a 3dB coupler and is thus an alternative to a magic tee.

A hybrid ring consists of an annular line of proper electrical length to sustain standing waves, to which four arms are connected at proper intervals by means of series or parallel junctions. The below figure shows a hybrid ring with series junctions.

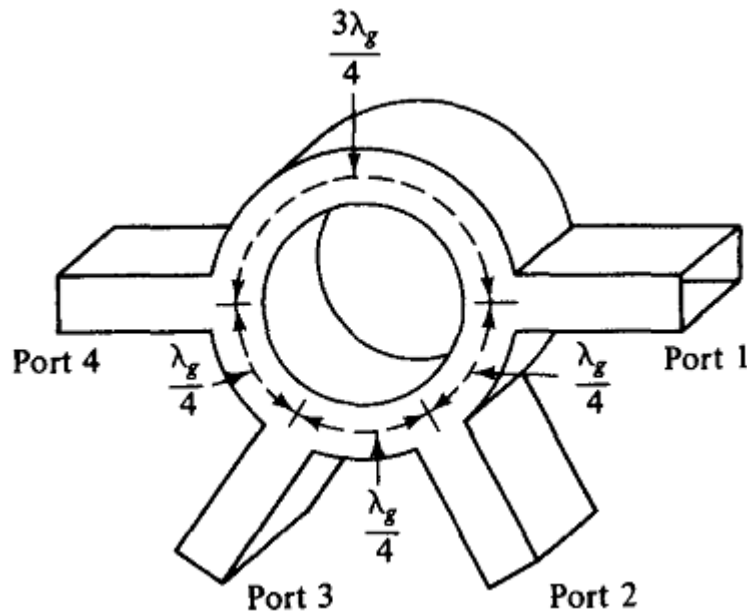

Fig hybrid ring with series junctions.

The hybrid ring has characteristics similar to those of the hybrid tee. When a wave is fed into port 1, it will not appear at port 3 because the difference of phase shifts for the waves traveling in the clockwise and counterclockwise directions is 180° . Thus the waves are canceled at port 3. For the same reason, the waves fed into port 2 will not emerge at port 4 and so on.

The S matrix for an ideal hybrid ring can be expressed as

$$[S] = \begin{bmatrix} 0 & S_{12} & 0 & S_{14} \\ S_{21} & 0 & S_{23} & 0 \\ 0 & S_{32} & 0 & S_{34} \\ S_{41} & 0 & S_{43} & 0 \end{bmatrix}$$

It should be noted that the phase cancellation occurs only at a designated frequency

for an ideal hybrid ring. In actual hybrid rings there are small leakage couplings, and therefore the zero elements in the matrix of Eq. are not quite equal to zero.

waveguide corners, bends and twists :

These waveguide components are normally used to change the direction of the guide through an arbitrary angle. In order to minimize reflections from the discontinuities, it is desirable to have the mean length L between continuities equal to an odd number of quarter-wave-lengths.

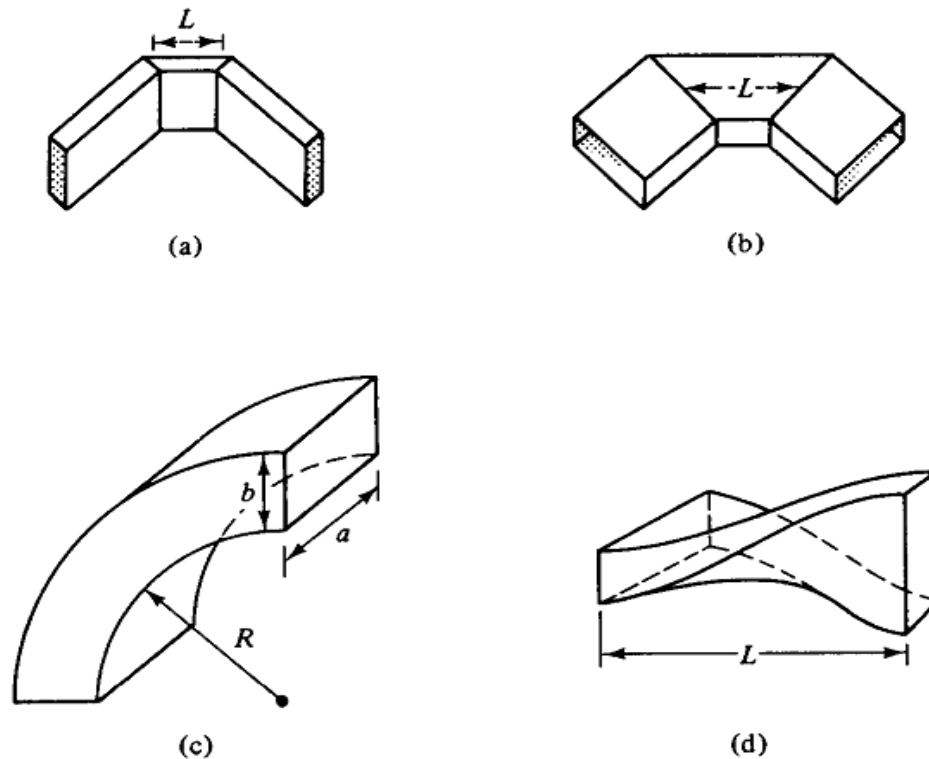

Fig Waveguide corner, bend, and twist. (a) E-plane corner. (b) H-plane corner. (c) Bend. (d) Continuous twist.

$$\text{That is, } L = \left(2n + 1\right) \frac{\lambda_g}{4}$$

where $n = 0, 1, 2, 3, \dots$, and λ_g is the wavelength in the waveguide. If the mean length L is an odd number of quarter wavelengths, the reflected waves from both ends of the waveguide section are completely canceled. For the waveguide bend, the minimum radius of curvature for a small reflection is given by South worth.

as $R = 1.5b$ for an E bend

$R = 1.5a$ for an H bend

Directional couplers :

A directional coupler is a four-port waveguide junction as shown in Fig. It consists of a primary waveguide 1-2 and a secondary waveguide 3-4. When all ports are terminated in their characteristic impedances, there is free transmission of power, without reflection, between port 1 and port 2, and there is no transmission of power between port 1 and port 3 or between port 2 and port 4 because no coupling exists between these two pairs of ports. The degree of coupling between port 1 and port 4 and between port 2 and port 3 depends on the structure of the coupler.

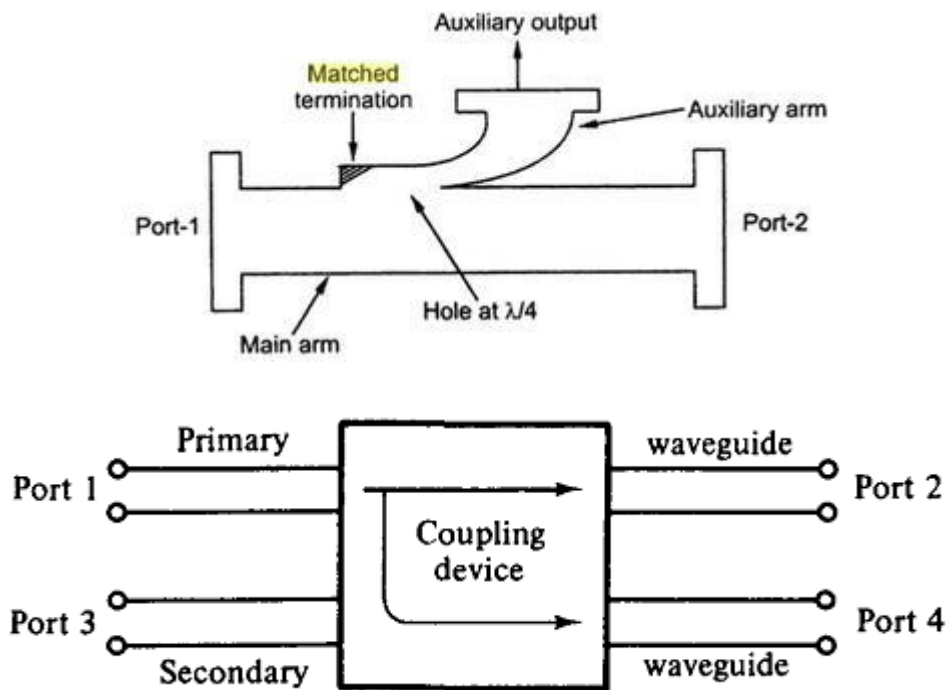

Fig Directional coupler.

The characteristics of a directional coupler can be expressed in terms of its coupling factor and its directivity. Assuming that the wave is propagating from port 1 to port 2 in the primary line, the coupling factor and the directivity are defined, respectively, by

$$\text{Coupling factor (dB)} = 10 \log_{10} \frac{P_1}{P_4}$$

$$\text{Directivity (dB)} = 10 \log_{10} \frac{P_4}{P_3}$$

It should be noted that port 2, port 3, and port 4 are terminated in their characteristic impedances. The coupling factor is a measure of the ratio of power levels in the primary and secondary lines. Hence if the coupling factor is known, a fraction of power measured at port 4 may be used to determine the power input at port 1. This significance is desirable for microwave power measurements because no disturbance, which may be caused by the power measurements, occurs in the primary line. The directivity is a measure of how well the forward traveling wave in the primary waveguide couples only to a specific port of the secondary waveguide. An ideal directional coupler should have infinite directivity. In other words, the power at port 3 must be zero because port 2 and port 4 are perfectly matched. Actually, well-designed directional couplers have a directivity of only 30 to 35 dB.

S Matrix of a Directional Coupler

In a directional coupler all four ports are completely matched. Thus the diagonal elements of the S matrix are zeros and

$$S_{11}=S_{22}=S_{33}=S_{44}=0$$

As noted, there is no coupling between port 1 and port 3 and between port 2 and port 4. Thus

$$S_{13}=S_{31}=S_{24}=S_{42}=0$$

Consequently, the S matrix of a directional coupler becomes

$$[S] = \begin{bmatrix} 0 & S_{12} & 0 & S_{14} \\ S_{21} & 0 & S_{23} & 0 \\ 0 & S_{32} & 0 & S_{34} \\ S_{41} & 0 & S_{43} & 0 \end{bmatrix}$$

Equation can be further reduced by means of the zero property of the S-matrix, so we have

$$S_{12}S_{14}^* + S_{32}S_{34}^* = 0$$

$$S_{21}S_{23}^* + S_{41}S_{43}^* = 0$$

Also from the unity property of S matrix, we can write

$$S_{12}S_{12}^* + S_{14}S_{14}^* = 1$$

Equation and..... can also be written as

$$|S_{12}||S_{14}| = |S_{32}||S_{34}|$$

$$|S_{21}||S_{23}| = |S_{41}||S_{43}|$$

Since, $S_{12} = S_{21}$, $S_{14} = S_{41}$, $S_{23} = S_{32}$ and $S_{34} = S_{43}$, then

$$|S_{12}| = |S_{34}|$$

$$|S_{14}| = |S_{23}|$$

Let

$$|S_{12}| = |S_{34}| = p$$

Where p is positive and real, then from equation

$$p(S_{23}^* + S_{41}) = 0$$

Let

$$S_{23} = S_{41} = jq$$

Where q is positive and real, then from equation

$$p^2 + q^2 = 1$$

The S matrix of a directional coupler is reduced to

$$S = \begin{bmatrix} 0 & p & 0 & jq \\ p & 0 & jq & 0 \\ 0 & jq & 0 & p \\ jq & 0 & p & 0 \end{bmatrix}$$

Circulators:

- A microwave circulator is a multiport device in which power is circulated from n th port to $(n+1)$ th port only in one direction.
- A four port circulator is most commonly used. Figure shows a four port circulator

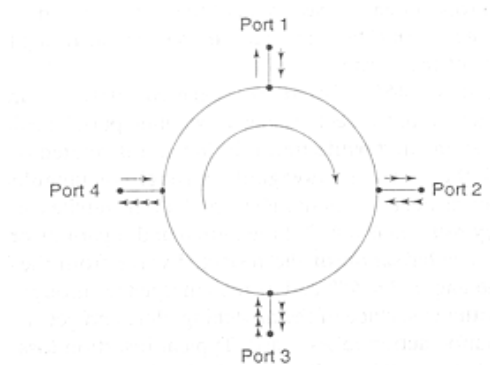

Fig; Circulator

Circulator is a non-reciprocal component. All the four ports are matched and transmission of power takes place in cyclic order only. An ideal circulator is perfectly lossless.

Principle of Operation

- Working of circulator is based on principle of Faraday rotation.
- All the ports 1, 2, 3 and 4 are oriented such that the E-field of transmitted signal couples to these ports successively after going through a rotation of 45° in clockwise direction.

Three Port Circulator

- A three port circulator is symmetrical Y type junction of three identical waveguides with an axially magnetized ferrite post placed at the center. Figure shows a typical three port circulator.

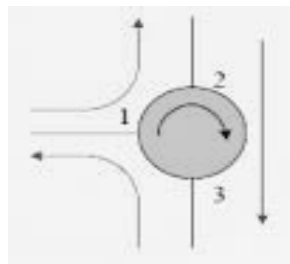

Fig: Three port circulator

- The ferrite post is magnetized by static B_0 field along the axis. It provides the necessary non reciprocal property. The junction can be matched by placing suitable tuning element in each arm.
- It is an essential component used to isolate the input and output in negative resistance amplifier. Three port circulators are also used to couple a transmitter to various receivers.

Four Port Circulator

- A four port Faraday rotation circulator is shown in figure below:

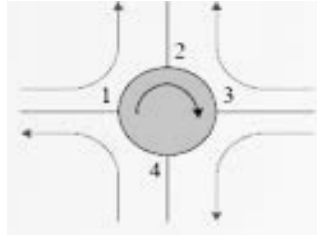

Fig: Four Port Circulator

- Power entering port-1 travels along the magnetized ferrite. The direction of the field vector gets rotated by 45° . Therefore power entered at port-1 appears at port-2.
- The power cannot be coupled to port-4 because ports-2 and 4 are 90° out of phase. Similarly, port-3 is coupled to port-4 and port-4 to port-1.

S-matrix of Circulator:

Its matrix is given by

$$[S] = \begin{bmatrix} S_{11} & S_{12} & S_{13} \\ S_{21} & S_{22} & S_{23} \\ S_{31} & S_{32} & S_{33} \end{bmatrix} \quad \text{-----(1)}$$

As its properly matched function,

$$S_{11} = S_{22} = S_{33} = 0$$

The circulator is a non-reciprocal device and hence it is not symmetrical. It means

$$S_{ij} \neq S_{ji}$$

But $[S]$ is unitary

$$[S][S^*] = 1$$

$$[S] = \begin{bmatrix} 0 & S_{12} & S_{13} \\ S_{21} & 0 & S_{23} \\ S_{31} & S_{32} & 0 \end{bmatrix} \quad [S^*] = \begin{bmatrix} 0 & S_{12}^* & S_{13}^* \\ S_{21}^* & 0 & S_{23}^* \\ S_{31}^* & S_{32}^* & 0 \end{bmatrix}$$

This gives

$$|S_{12}|^2 + |S_{13}|^2 = 1 \quad \text{--->} \quad |S_{13}|^2 = 1 - |S_{12}|^2 \quad \text{-----(2)}$$

$$|S_{21}|^2 + |S_{23}|^2 = 1 \quad \text{--->} \quad |S_{23}|^2 = 1 - |S_{21}|^2 \quad \text{-----(3)}$$

$$|S_{31}|^2 + |S_{32}|^2 = 1 \quad \text{--->} \quad |S_{32}|^2 = 1 - |S_{31}|^2 \quad \text{-----(4)}$$

Using zero property of S matrix,

$$S_{13} S_{23}^* = 0, \quad S_{12} S_{32}^* = 0, \quad S_{21} S_{31}^* = 0 \quad \text{and using zero property,}$$

$$S_{23} = 0 \quad S_{12} = 0 \quad S_{31} = 0$$

$$|S_{12}| = 1, \quad S_{23} = 0$$

$$|S_{32}| = 1, \quad S_{31} = 0$$

$$|S_{13}| = 1, \quad S_{12} = 0$$

$$[S] = \begin{bmatrix} 0 & 0 & S_{13} \\ S_{21} & 0 & 0 \\ 0 & S_{32} & 0 \end{bmatrix}$$

Thus,

$$[S] = \begin{bmatrix} 0 & 0 & 1 \\ 1 & 0 & 0 \\ 0 & 1 & 0 \end{bmatrix}$$

Applications of Circulator

- Isolation of transmitters and receivers connected to same antenna e.g. in radar system.
- Isolation of input and output in two terminal amplifying devices e.g. parametric amplifiers.

Isolators:

- Isolator is a non-reciprocal ferrite transmission device. Isolators are generally used to improve the frequency stability of microwave generators.
- Isolators transmit electromagnetic wave only in one direction, the reflected wave is attenuated (absorbed). Thus microwave generating active devices are isolated.
- An ideal isolator completely absorbs power of propagation in one direction and provides lossless transmission in the opposite direction.
- The Faraday rotation provides 1 dB insertion loss in forward transmission and about 20 to 30 dB isolation in reverse direction.

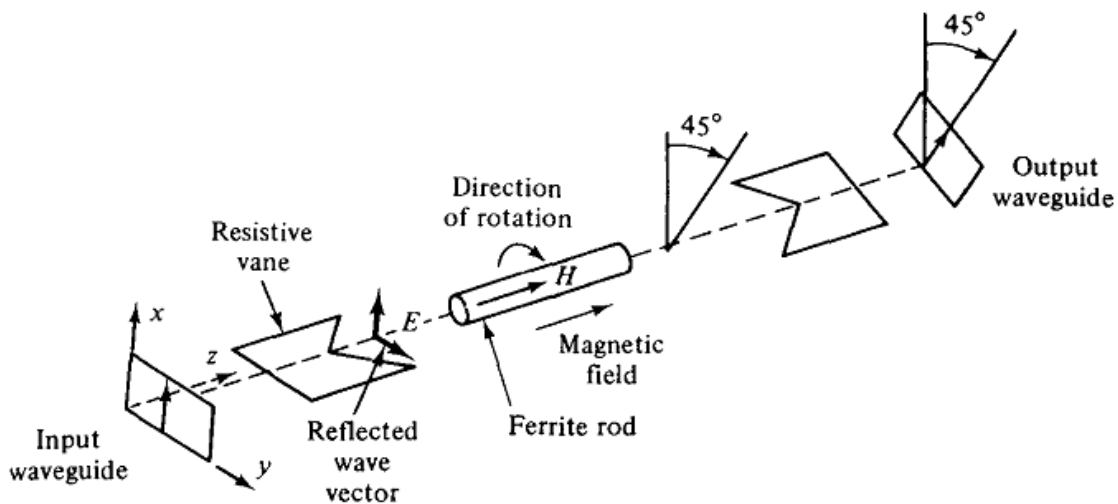

Fig Isolators

- Let the incident wave has E in x-direction when it propagates through ferrite rod, it is rotated by 45°. It is launched into waveguide which is at 45°.
- Reflected wave from load travels in reverse direction and is again rotated by 45° by ferrite rod. Reflected E appearing at resistive vane-1 is in Y-direction and it is completely attenuated.
- The performance of an isolator is measured in terms of two basic parameters.

Insertion Loss (IL)

Insertion loss is defined as the ratio of power at the input power to the power received at the output port. It is expressed as,

$$I_L (dB) = 10 \log \frac{P_1}{P_2}$$

Where, P1 → Power launched at input port

P2 → Power received at output port

Isolation loss(Is)

Isolation is defined as the ratio of power reflected from the output port to the power at the input port. It is expressed as

$$I_S (dB) = 10 \log \frac{P_2'}{P_1'}$$

Where, P1' → Power at input port

P2' → Power launched from output port

For an ideal lossless matched isolator

| S₂₁ | = 1, | S₁₂ | = | S₁₁ | = | S₂₂ | = 0

$$[S] = \begin{bmatrix} 0 & 0 \\ 1 & 0 \end{bmatrix}$$

Application of Isolator

- In Klystrons and Magnetrons to improve the frequency stability.

Microwave Measurements: VSWR

VSWR stands for **Voltage Standing Wave Ratio**, and is also referred to as Standing Wave Ratio (SWR). **VSWR** is a function of the reflection coefficient, which describes the power reflected from the antenna.

- Two commonly used methods for measuring VSWR are:
 1. Slotted Line Technique – for Low VSWR ($S < 20$)
 2. Double Minimum Method – for High VSWR ($S > 20$)
- When load impedance is not equal to source impedance, standing waves are produced. By inserting a slotted line section in the transmission line, standing waves can be traced by moving the carriage with a tunable probe detector along the line.
- VSWR can be measured by detecting V_{max} and V_{min} in the VSWR meter:

$$S = V_{max} / V_{min}$$

- The setup for measuring VSWR using slotted line technique is shown in the figure below:

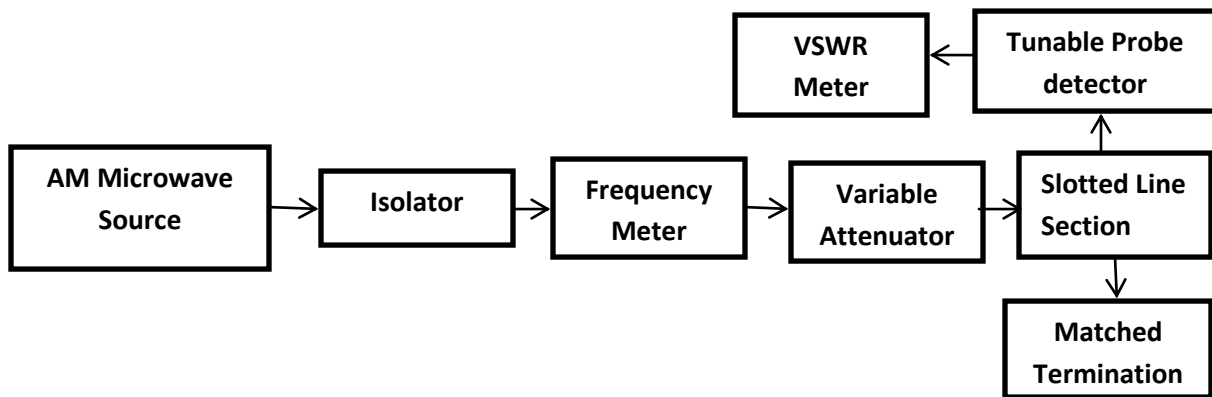

Fig: Slotted Line Method of VSWR Measurement - Basic Experimental Setup

- The variable attenuator is adjusted to 10dB. The microwave source is set to required frequency. The 1 KHz modulation is adjusted for maximum reading on the VSWR meter in a 30dB scale. The probe carriage stub is tuned for maximum detected signal in VSWR meter.
- The probe carriage is slid along the non-radiating slot from the load end until a peak reading is obtained in VSWR meter. The meter's gain control is adjusted to get the meter reading at 1.0 or 0dB corresponding to the position of voltage maximum.
- The probe is moved towards the generator to an adjacent voltage minimum. The

corresponding reading in VSWR meter directly gives the $VSWR = V_{max} / V_{min}$ on the top of SWR normal scale for $1 \leq S \leq 4$ or on the Expanded scale for $1 \leq S \leq 1.33$.

- The experiment is repeated for other frequencies as required to obtain a set values of S Vs f.
- For VSWR between 3.2 and 10, a 10dB lower range should be selected and reading corresponding to V_{min} position should be taken from the second VSWR normal scale from the top.

Power for VSWR:

- Power is defined as the quantity of energy dissipated or stored per unit time. The range of microwave power is divided into three categories – low power (less than 10mW), medium power (from 10mW to 10W) and high power (greater than 10W).
- The average power is measured while propagation in a transmission medium and is defined by,

$$P_{av} = \frac{1}{nT} \int_0^{nT} v(t)i(t)dt$$

Where, T is the time period of the lowest frequency involved in the signal and n cycles are considered. For pulsed signal

$$P_{peak} = \frac{1}{T} \int_0^T v(t)i(t)dt$$

$$P_{av} = P_{peak} * \text{Duty Cycle}$$

$$\text{Duty cycle} = \text{pulse width} * \text{p. r. f.} = \tau f_r = \tau T < 1$$

Where τ is the pulse width, T is the period and f_r is the pulse repetition frequency. The most convenient unit of power at microwaves is dBm.

$$P(\text{dBm}) = 10 \log \frac{P(\text{mW})}{1\text{mW}}$$

$$\text{viz., } 30 \text{ dBm} = 1\text{W} \text{ and } -30 \text{ dBm} = 1\mu\text{W}.$$

- The sensors used for power measurements are the schottky barrier diode, bolometer and the thermocouple.

Impedance scattering parameters:

Impedance can be measured by the following two methods:

- i. Slotted Line Method
- ii. Impedance measurement

Slotted Line Method:

- For high frequencies, the impedance will be complex. The complex impedance Z_L of the load can be measured by measuring the phase angle ϕ_L of the complex reflection co-efficient Γ_L from the distance of first voltage standing wave minimum (d_{min}) and the magnitude of the same from the VSWR, S .
- The equation below gives the relation between the load impedance and the reflection co-efficient for the computation of Z_L .

$$Z_L = Z_0 \frac{1 + \Gamma_L}{1 - \Gamma_L}$$

Where, $\Gamma_L = \rho_L e^{j\phi_L}$ and $S = (1 + \rho_L)(1 - \rho_L)$ or $\rho_L = \frac{1-S}{1+S}$

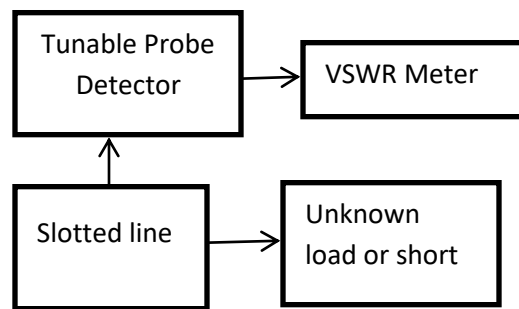

Fig: Determination of load impedance using slotted line

- The method of using slotted line to determine an unknown impedance is explained as follows:
 1. Adjust the probe depth of the slide screw tuner to an approximate level.
 2. Move the probe position of the SWR, to a minimum and note down the Vernier reading (d_1).
 3. Also note down the corresponding SWR value (S) on the SWR meter.
 4. Remove the load and connect only the tunable detector or movable short.
 5. Move the probe position of SWD carefully in any one direction and note down the Vernier reading (d_2) for two successive minima d_1 and d_2 .

6. Calculate the guide wavelength, λ_g as, $\lambda_g = 2 \times \text{distance between successive minima}$ i.e. $\lambda_g = 2(d_1 - d_2)$ and $\beta = 2\pi/\lambda_g$
7. Now the phase angle can be calculated by the formula, $\varphi_L = 2\beta d_{\min} - \pi$
8. The unknown impedance of the load is calculated from the above said relation,

$$Z_L = Z_o \frac{1 + \Gamma_L}{1 - \Gamma_L}$$

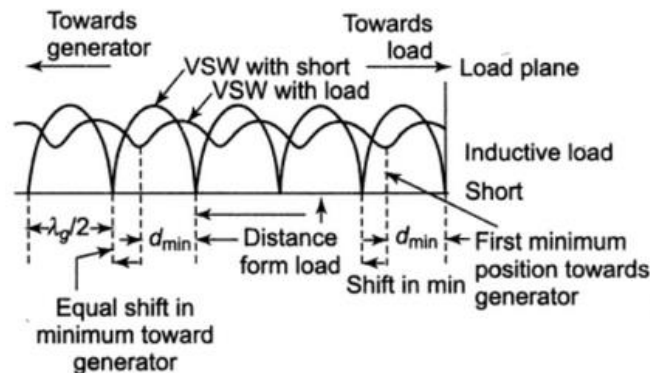

Fig: Determination of d_{\min}

- To ease the calculation, smith chart Z_L from the measurements of S and d_{\min} as following:
 1. Draw a circle on the Smith chart corresponding to the SWR values (S).
 2. Locate the point X on the chart.
NOTE: (a) $d_1 - d_2 > 0$ (corresponding to wavelength towards load)
(b) $d_L - d_S < 0$ (corresponding to wavelength towards generator).
 3. Draw the line from the point $(1 + j0)$ to X .
 4. Identify the Z_L as the impedance at the point of intersection of S circle and the line joining $(1 + j0)$ and X . Therefore,
 $Z_L = (\text{impedance obtained from Smith chart}) \times (\text{characteristics impedance})$.
- For Example. Let us consider $VSWR(S) = 2$ and $(d_{\min} / \lambda_g) = 0.2$ say,
 - Draw the VSWR circle centered at 0 ($r=1$) with radius cutting the r -axis at $S=2$.
 - Move from the short circuit load point A on the chart along the wavelengths toward load scale by distance (d_{\min} / λ_g) B . join OB .
 - The point of intersection between the line OB and the VSWR circle gives the

normalized load $z_L = Z_L/Z_0$ and hence the complex load

$$Z_L = Z_0 \times (1.0 + j 0.7)$$

Dielectric constant measurements:

- The dielectric constant ϵ_r is defined by the permittivity ϵ of the material with respect to that ϵ_0 of air or free space

$$\epsilon_r = \epsilon/\epsilon_0, \epsilon_0 = \left(\frac{10^{-9}}{36\pi}\right) \frac{\text{farad}}{\text{m}}$$

- Due to presence of non-zero conductivity, dielectric material exhibits loss resulting in complex value represented by,

$$\epsilon_r = \epsilon' r + j\epsilon'' r$$

- The loss tangent, $\tan \delta = \epsilon'' r / \epsilon' r$
- The measurement of the complex dielectric constant is required not only in scientific application but also for industrial applications such as microwave heating or ovens and to study the biological effects of microwaves.
- The dielectric constant is not independent of frequency and for most common microwave applications. On the other hand, the percent variation in $\epsilon'' r$ is almost always greater than that of $\epsilon' r$ so that $\epsilon'' r$ should be measured near the frequency or frequencies of interest.
- There are several methods available for dielectric constant measurement. The following sections describe two commonly used methods: the waveguide method and cavity perturbation method.

Waveguide Method

- In this method it is assumed that the material is lossless. A dielectric sample AB completely fills a length of the waveguide and the end is terminated in a short as shown in figure:
- A voltage standing wave minimum is observed in the slotted line at C (say)

Let, $l_e = AB =$ the dielectric sample length

$$l_o = BC$$

- Then the distance of V_{\min} from short circuit = $l_e + l_o = AC$. For a dielectric filled guide

of characteristics impedance Z_e , input impedance at β is purely reactive,

$$Z_{in}' = jZ_e \tan \beta l_e, \text{ where } \beta \text{ is propagation constant}$$

- Using this Z_{in}' as termination at β , input impedance at C for the empty guide is

$$Z_{inC} = \frac{Z_{in}' + j Z_o \tan \beta l_o}{Z_o + j Z_{in}' \tan \beta l_o} = 0, \text{ at } V_{min} \text{ point}$$

Therefore, $Z_{in}' + j Z_o \tan \beta l_o = 0$ or $jZ_e \tan \beta l_e + j Z_o \tan \beta l_o = 0$

$$\text{Or, } Z_o \tan \beta l_o = -Z_e \tan \beta l_e$$

Assuming nonmagnetic dielectric in the waveguide,

$$\frac{Z_o}{Z_e} = \frac{\beta_e}{\beta_o}$$

$$\text{Or, } Z_o = \frac{\beta_e}{\beta_o} \cdot Z_e$$

Substituting this value, we get,

$$\frac{\beta_e}{\beta_o} \cdot Z_e \cdot \tan \beta l_o = -Z_e \tan \beta l_e$$

$$\text{or, } \frac{l_o \tan \beta l_o}{\beta l_o} = - \frac{l_e \tan \beta l_e}{\beta l_e}$$

$$\text{or, } \frac{l_o \cdot \tan Y}{l_e \cdot Y} = - \frac{\tan X}{X}; \text{ where } X = \beta l_e; Y = \beta l_o$$

For dominant mode, $\beta_o = 2\pi/\lambda_{g0}$ and $\lambda_{g0} = 2 * \text{distance between two successive } V_{min}$

Which can be measured by the slotted line, l_o and l_e are also measured in the slotted line. Therefore, the left hand side of the above transcendental is known and it can be written as $\frac{\tan X}{X} = -\alpha$

The above equation can be solved for determining $X = \beta l_e$, now

$$\beta_e = \frac{2\pi}{\lambda_{ge}} = \frac{2\pi}{\lambda_o} \sqrt{\left[\epsilon_r - \left(\frac{\lambda_o}{\lambda_c} \right)^2 \right]}, \lambda_c = 2a, \text{ where } a - \text{ waveguide broadwall dimension.}$$

Since β_e is known, ϵ_r . Hence two different lengths of sample are taken for two sets of solutions.

For length l_e : $X = X_1, X_2, \dots$; $\epsilon_r = \epsilon_{r1}, \epsilon_{r2}, \dots$

For length l'_e : $X = X'_1, X'_2, \dots$; $\epsilon'_r = \epsilon'_{r1}, \epsilon'_{r2}, \dots$

Antenna radiation pattern and gain measurement:

- The radiation pattern is a representation of the radiation characteristics of the antenna as a function of elevation angle θ and azimuthal angle ϕ for a constant radial distance and frequency.
- The three-dimensional pattern is decomposed into two orthogonal two-dimensional patterns in E and H field's planes where the Z-axis is the line joining the transmitting and receiving antennas and perpendicular to the radiating apertures.
- Due to the reciprocal characteristics of antennas, the measurements are performed with the test antenna placed in the receiving mode.
- The source antenna is fed by a stable source and the received signal is measured using a receiver.
- Or capacitive causes error in measurement. The output of the receiver is fed to Y-axis input of an XY receiver.
- The receiving antenna positioner controller plane and the angle information is fed to X-axis input of the XY recorder.
- Thus the amplitude Vs angle plot is obtained from the receiver output.
- Initially two antennas are aligned in the line of their maximum radiation direction by adjusting the angle and height by the controller and the antenna mast. Effects of all surrounding are removed or suppressed through increased directivity and low side lobes of the source antenna, clearance of LOS, and absorption of energy reaching the range surface.
- The following precautions are taken for better accuracy in the measurements:
 1. Effects of coupling between antennas-inductive or capacitive causes error measurements. The former exists at lower microwave frequencies and negligible if range $R \geq 10 \lambda$. Mutual coupling due to scattering and retardation of energy by test and source antenna causes error in measurement.
 2. Effect of curvature of the incident phase front produces variation over the aperture of test antenna and this restricts the range R. for a phase deviation at the edge $\leq \pi/8$ radians, $R \leq 2D^2 \lambda$, where D is the maximum size of the aperture.

3. Effect of amplitude taper over the test aperture will give deviation of the measured pattern from the actual. This occurs if the illuminating field is not constant over the region of the test aperture. Tolerable limit of amplitude taper is 0.25 dB, for which decrease in gain is 0.1 dB,
4. Interference from spurious radiating sources should be avoided.

Phase measurement of antenna:

- The phase of the radiated field is a relative quantity and is measured with respect to a reference as shown in figure below:

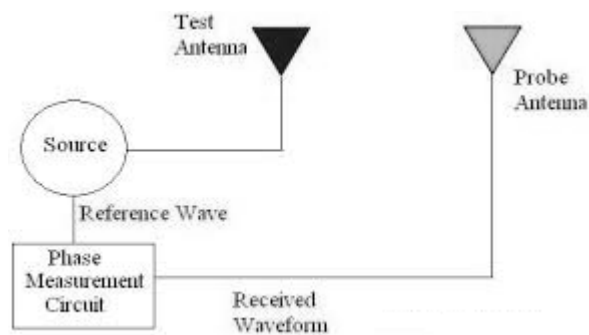

Fig: Phase pattern Measurement

- This reference is provided either by coupling a fraction of the transmitted signal to the reference channel of the receiver or by receiving the transmitted signal with a fixed antenna placed near the test antenna. The fixed antenna output is fed to the reference channel of the receiver and the phase pattern is recorded as the antenna under the test is rotated in the horizontal plane.

Gain of the antenna:

There are three basic methods that can be used to measure the gain:

1. Standard Antenna Method
2. Two antenna method
3. Three antenna method

1. Standard Antenna Method

- This method uses two sets of measurements with the test and standard gain antennas. Using the test antenna of gain G_r in receiving mode, the received power, P_r is recorded in a matched recorder.

- The test antenna is then replaced by a standard gain antenna of gain G_s and the received power, P_s is again recorded without changing the transmitted power and geometrical configuration. Then,

$$P_r/P_s = G_r/G_s$$

$$\text{Or, } G_r(\text{dB}) = G_s(\text{dB}) + 10 \log\left(\frac{P_r}{P_s}\right)$$

- Thus by measuring the received power with test and standard gain antennas and knowing gain G_s of the standard gain antenna, the gain of the test antenna can be found.

2. Two Antenna Method

- In this method, the signal is transmitted from a transmitting antenna of gain G_t , and the signal is received by the test antenna of gain G_r placed at far-field distance R . The received power is expressed by,

$$P_r = \frac{P_t G_t G_r \lambda^2}{(4\pi R)^2}$$

$$\text{or, } G_r(\text{dB}) + G_t(\text{dB}) = 20 \log\left(\frac{4\pi R}{\lambda}\right) + 10 \log\left(\frac{P_r}{P_t}\right);$$

Where, P_r is the received power and P_t is the transmitted power. When the two antennas are selected identical, $G_r = G_t$ so that

$$G_r(\text{dB}) = G_t(\text{dB}) = 10 \log\left(\frac{4\pi R}{\lambda}\right) + 5 \log\left(\frac{P_r}{P_t}\right)$$

- By measuring R , λ and P_r / P_t , the gain G_r can be determined.

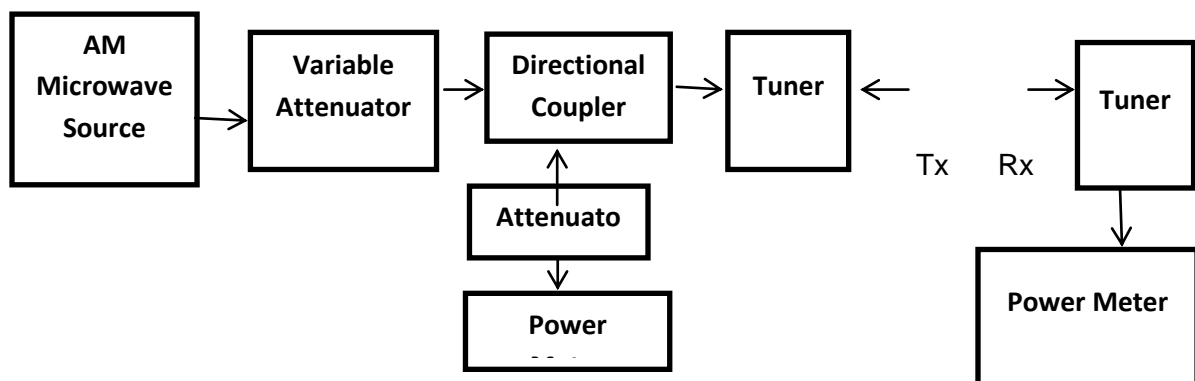

Fig: Block Diagram of Antenna Gain Measurements

3. Three Antenna Method

- In two antenna method if the measuring systems are not exactly identical, error will be introduced. Hence three antenna method is the most general method to find gain of all the three antennas. Any two antennas are used at a time i.e 1 and 2, 2 and 3, and 3 and 1, respectively.
- The following equations can be developed for the received and transmitted powers.

$$G1(\text{dB}) + G2(\text{dB}) = 20 \log\left(\frac{4\pi R}{\lambda}\right) + 10 \log\left(\frac{Pr2}{Pt1}\right);$$

$$G2(\text{dB}) + G3(\text{dB}) = 20 \log\left(\frac{4\pi R}{\lambda}\right) + 10 \log\left(\frac{Pr3}{Pt2}\right);$$

$$G3(\text{dB}) + G1(\text{dB}) = 20 \log\left(\frac{4\pi R}{\lambda}\right) + 10 \log\left(\frac{Pr1}{Pt3}\right).$$

- Since R and λ are known and (Pr/Pt)'s measured, the right hand side of the above equations are known. The three unknown quantities G1, G2 and G3 can be determined from the above three equations.
- For accuracy of the measurements, care must be taken so that
 1. All antennas meet the far field criteria: $R \geq 2D^2/\lambda$
 2. The antennas are aligned for bore=sight radiation face – to face.
 3. The measuring system is frequency stable.
 4. Impedance mismatched in the system components is minimum.
 5. Polarization mismatch is minimum.
 6. Reflection from various background and support structure is minimum.

UNIT – III Optical Fibers

Element of an Optical Fiber Transmission link :

A fiber optic data link sends input data through fiber optic components and provides this data as output information. It has the following three basic functions:

- To convert an electrical input signal to an optical signal
- To send the optical signal over an optical fiber
- To convert the optical signal back to an electrical signal

A fiber optic data link consists of three parts – transmitter, optical fiber and receiver. Figure below shows the fiber optic connection. The transmitter, optical fiber and receiver perform the basic functions of the fiber optic data link.

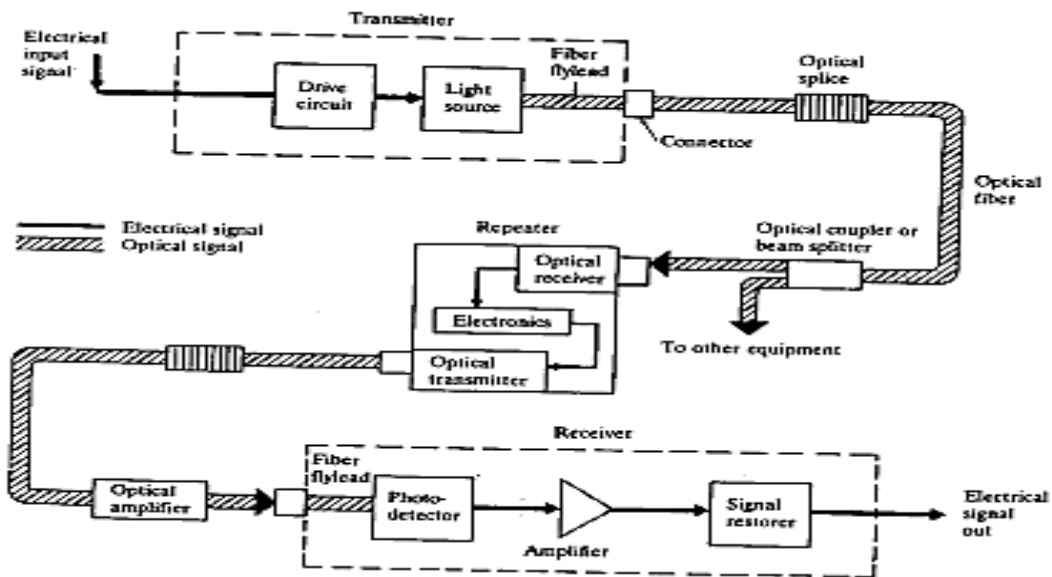

Fig: Major Elements of a Optical Fiber Transmission Link

- The transmitter, consisting of a light source can effectively convert an electrical input signal to an optical signal and launch the data containing light down the optical fiber.
- A receiver consisting of a photodetector plus amplification and signal-restoring circuitry, can effectively detects the optical signal and transform this optical signal back into its original form.
- Additional components include optical connectors, splices, couplers or beam splitters and repeaters.

Transmitter

- The transmitter is used to launch optical power into the fiber.
- The two types of optical sources are: light-emitting diode(LEDs) and Laser diodes.
- The electric input signals to the transmitter circuitry converts these electric signals to an optical signal by varying the current flow through the light source.
- An optical source is a square-law device, which means that a linear variation in drive current results in a corresponding linear change in the optical output power.
- In the 800-900 nm region the light sources are generally alloys of GaAlAs. At the longer wavelengths (1100 to 1600 nm), an InGaAsP alloy is the principal optical source material.
- After an optical signal has been launched into the fiber, it will become progressively attenuated and distorted with increasing distance because of scattering, absorption and dispersion mechanisms in the waveguide.
- When an optical signal has travelled a certain distance along the fiber, the signal has become attenuated and distorted to such a degree that a repeater is needed in the transmission line to amplify and reshape the signal.
- An optical repeater consists of a receiver and a transmitter placed back to back. The receiver section detects the optical signal and converts it to an electric signal, which is amplified, reshaped and sent to the electric input of the transmitter section.
- The transmitter section converts this electric signal back to an optical signal and sends it on down the optical fiber waveguide.
- Finally, The coupler must efficiently transfer the modulated light beam from the source to the optic fiber.

Information Channel

- The information channel is the path between the transmitter and receiver.
- The cabled optical fiber is one of the most important elements in an optical fiber link. In addition to protecting the glass fibers during installation and service, the cable may contain copper wires for powering repeaters which are needed for periodicity amplifying and reshaping the signal when the link spans long distances.
- The cable generally contains several cylindrical hair-thin glass fibers, each of which is an independent communication channel. Analogous to copper cables, the installation of optical fiber cables can be aerial in ducts, undersea or buried directly in the ground.
- Individual cable lengths will range from several hundred meters to several kilometers for long- distance applications. The shorter lengths tend to be used when the cables are pulled through ducts. Longer cable lengths are used in aerial or direct-burial applications.
- The complete long distance transmission line is formed by splicing or connecting together these cable sections.

Receiver

- The design of the receiver is inherently more complex than that of the transmitter, since it has to both amplify and reshape the degraded signal received by the photodetector.
- The ability of a receiver to achieve a certain performance level depends on the photodetector type, the effects of noise in the system, and the characteristics of the successive amplification stages in the receiver.
- At the receiver the attenuated and distorted modulated optical power emerging from the fiber end will be detected by a photodiode.
- Analogous to the light source, the photodetector is also a square-law device since it converts the received optical power directly into an electric current output (photocurrent).
- Semiconductor pin and avalanche photodiodes (APDs) are the two principal photodetectors used in a fiber optical link.
- For low power application optical signal is received an avalanche photodiode is normally used, since it has greater sensitivity.
- Silicon photodetectors are used in the 800-900 nm regions. A variety of optical detectors are available at the longer wavelengths. The prime material candidate in the 1100 to 1600 nm region is an InGaAs alloy.
-

Advantages Of Optical Communication System:

1. Enormous Potential Bandwidth:

The optical carrier frequency in the range of 10^{13} to 10^{16} Hz (10^{14} Tera hertzange) gives a greater potential transmission bandwidth than metallic cable system.

2. Small Size and Weight:

Optical fiber has a very small diameter (diameter of a human hair) .Hence, even such fibers are converted with protective coatings they are far smaller and lighter than copper cables.

3. Electrical Isolation:

Optical fiber which are fabricated from glass or plastic polymer are electrical insulators unlike their metallic counter parts, they do not exhibit earth loop and interface problem. Therefore, Optical fiber transmission is ideally suited for electrical hazardous environment as the fiber creates no arcing (or) spark hazard at abrasion (or) short circuits.

4. Immunity to Interference and Crosstalk:

- Optical fiber forms a dielectric wave guide and free from electromagnetic interference (EMI), radio frequency interference (RFI) (or) switching transient giving electromagnetic pulses (EMP).
- Optical fiber transmission requires no shielding from EMI when it is used in electrically noisy environment.

- Fiber cable also not suitable to lightning strikes if used over head rather underground.

5. Signal Security:

- The light from optical fiber doesn't radiate significantly and therefore likely provide a high degree of signal security.
- Transmitted optical signal cannot be trapped by third person. This feature is attractive for military, banking and general data transmission applications.

6. Low Transmission Loss:

- Optical fiber exhibit low attenuation (or) transmission loss in comparison with the best copper conductors. Fibers have been fabricated with losses as low as 0.2 dB/km.

7. Ruggedness and Flexibility:

- Fibers are manufactured with high tensile strengths. The fibers may also be bent to quite small radii (or) twisted without damage.
- Because of the small sized, weight and flexibility optical fibers are generally superior in terms of storage, transportation, handling and installation to corresponding copper cables.

8. System Reliability And Ease Of Maintenance:

- □Low loss property of optical fiber cables reduces the requirements for intermediate repeaters (or) line amplifiers to boost the transmitted signal strength with fewer repeaters reliability is enhanced in comparison to conventional electrical system.
- Life time of optical fibers is 20 to 30 years. It reduces maintenance time and cost.

Propagation of light :

- Until the early seventeenth century it was generally believed that the light consisted of a stream of minute particles that were emitted by luminous sources.
- These particles were pictured as travelling in straightlines, and it was assumed that they could penetrate transparent materials but were reflected from opaque ones.
- This theory adequately described certain large scale optical effects such as reflection and refraction, but failed to explain finer-scale such as interference and diffraction.
- Later the work of Maxwell in 1864 theorized that light waves must be electromagnetic in nature.
- Furthermore observation of polarization effects indicated that light waves are transverse (that is, the wave motion is perpendicular to the direction in which the wave travels.)
- The electromagnetic wave radiated by a small optical source can be represented by a train of spherical wave fronts with the source at the center as shown in figure.

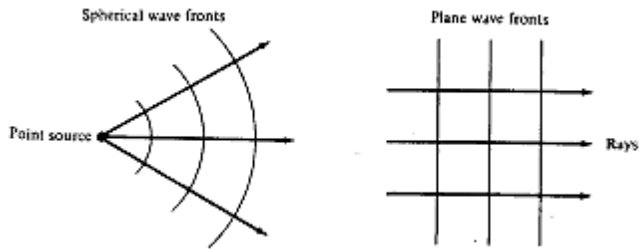

Fig; Representation of Spherical and Plane Wave front

- A wave front is defined as the locus of all points in the wave train which have the same phase.
- The speed of electromagnetic wave (c) in free space is approximately 3×10^8 m/sec.
- The distance travelled during each cycle is called as wavelength (λ)

$$\lambda f = c$$

Where,

c - Velocity of electromagnetic radiation, usually called the speed of light.

λ - Wavelength

f - Frequency

- In fiber optics, it is more convenient to use the wavelength of light instead of the frequency with light frequencies; wavelength is often stated in microns or nanometers.

1 micron (μ) = 1 Micrometre (1×10^{-6})

1 nano (n) = 10^{-9} metre

- Fiber optics uses visible and infrared light. Infrared light covers a fairly wide range of wavelengths and is generally used for all fiber optic communications. Visible light is normally used for very short range transmission using a plastic fiber.
- The photon energy is found to depend only on the frequency. This frequency in turn, must be measured by observing a wave property of light.
- The relationship between the energy E and the frequency ν of a photon is given by,

Where, $h = 6.625 \times 10^{-34}$ J is Planck's constant.

- When light is incident on an atom, a photon can transfer its energy to an electron within this atom, thereby exciting it to a higher energy level.
- The energy absorbed by the electron must be exactly equal to that required to excite state can drop to a lower state separated from it by an energy $h\nu$ by emitting a photon of exactly this energy.
- Before studying how the light actually propagates through the fiber, laws governing the

nature of light must be studied. This is called as laws of optics (Ray theory).

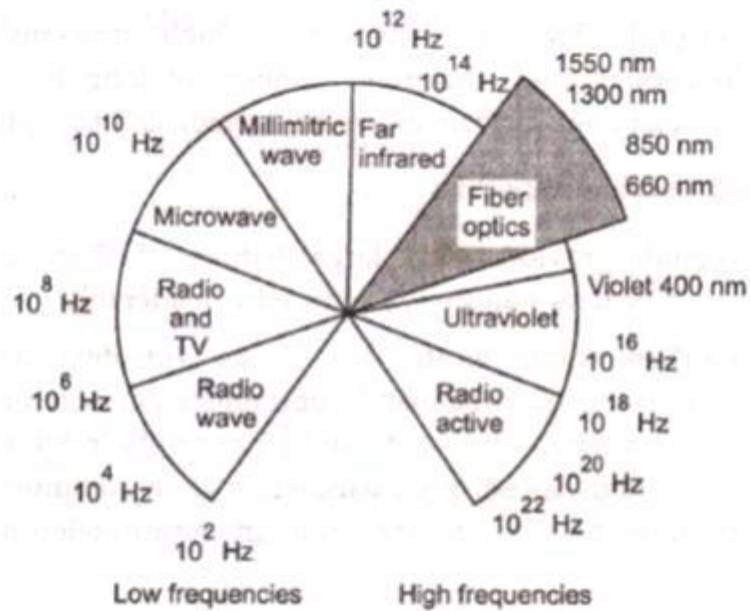

Fig: Electromagnetic Spectrum

- The speed of light depends upon the material or medium through which it is moving. In free space light travels at its maximum possible speed i.e. 3×10^8 m/s or 186×10^3 miles/sec.
- When light travels through a material it exhibits certain behavior explained by laws of reflection, refraction.

Reflection

- The law of reflection states that, when a light ray is incident upon a reflective surface at some incident angle from imaginary perpendicular normal, the ray will be reflected from the surface at some angle from normal which is equal to the angle of incidence.

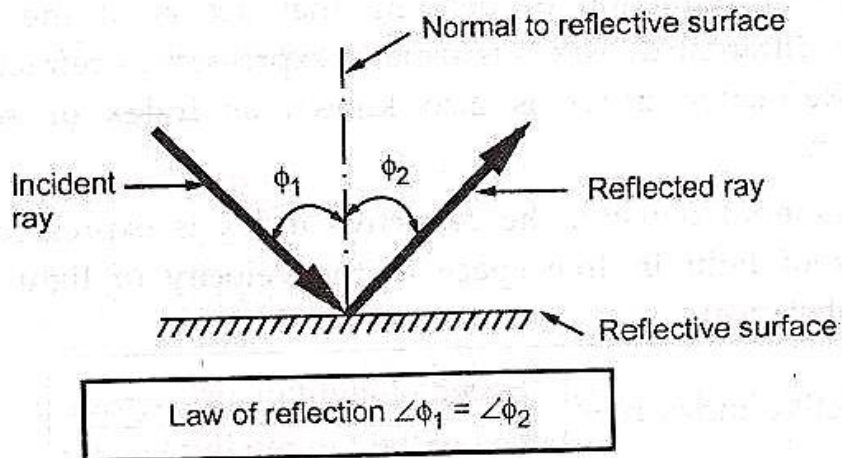

Fig: Reflection

Refraction

- Refraction occurs when light ray passes from one medium to another i.e. the light ray changes its direction at interface. Refraction occurs whenever density of medium changes. E.g. refraction occurs at air and water interface, the straw in a glass of water will appear as it is bent.
- The refraction can also be observed at air and glass interface.
- When a wave passes through a less dense medium to a denser medium, the wave is refracted (bent) towards the normal. Fig. below shows the refraction phenomena.

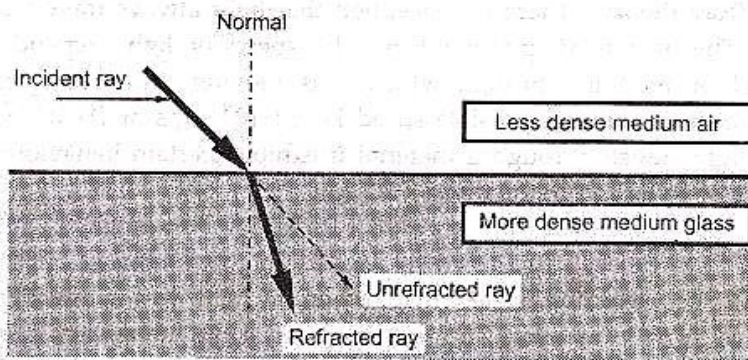

Fig: Refraction

- The refraction (bending) takes place because light travels at different speeds in different mediums. The speed of light in free space is higher than in water or glass.

Refractive Index

- The amount of refraction or bending that occurs at the interface of two materials of different densities is usually expressed as refractive index of two materials. Refractive index is also known as index of refraction and is denoted by n .
- Based on material density, the refractive index is expressed as the ratio of the velocity of light in free space to the velocity of light of the dielectric material (substance).

$$\text{Refractive index, } n = \frac{\text{Speed of light in air}}{\text{Speed of light in medium}} = \frac{c}{v}$$

- The refractive index for vacuum and air is 1.0. For water it is 1.3 and for glass refractive index is 1.5.

Snell's Law

- Snell's law states how light ray reacts when it meets the interface of two media having different indexes of refraction.
- Let the two medias have refractive indexes n_1 and n_2 where $n_1 > n_2$. Let θ_1 and θ_2 be the angles of incidence and angle of refraction respectively. Then according to Snell's law, a relationship exists between the refractive index of both materials given by,

$$n_1 \sin \theta_1 = n_2 \sin \theta_2$$

Where, n_1 is the refractive index of the core

n_2 is the refractive index of the cladding

- A refractive index model for Snell's law is shown in figure below:

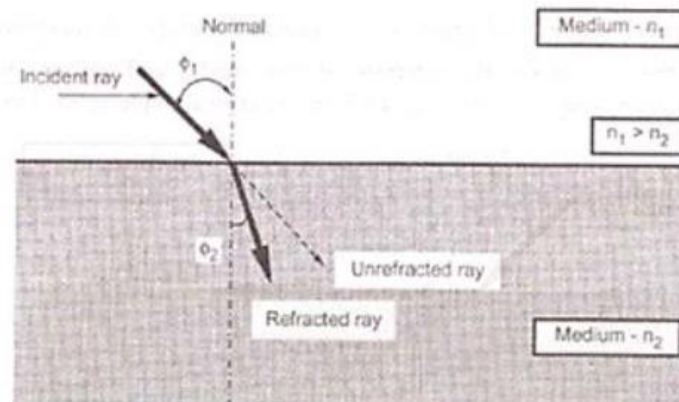

Fig: Refractive Model for Snell's law

- The refracted wave will be towards the normal when $n_1 < n_2$ and will away from it when $n_1 > n_2$. And, the equation below shows that the ratio of refractive index of two mediums is inversely proportional to the refractive and incident angles.

$$\frac{n_1}{n_2} = \frac{\sin \theta_2}{\sin \theta_1}$$

Critical Angle

- When the angle of incidence (θ_1) is progressively increased, there will be progressive increase of refractive angle (θ_2). At some condition, the refractive angle (θ_2) becomes 90° to the normal. When this happens the refracted light ray travels along the interface. The angle of incidence (θ_1) at the point at which the refractive angle (θ_2) becomes 90° is called the critical angle. It is denoted by θ_c .
- The **critical angle** is defined as the minimum angle of incidence (θ_1) at which the ray strikes the interface of two media and causes an angle of refraction (θ_2) equal 90° . Fig shows critical angle refraction.

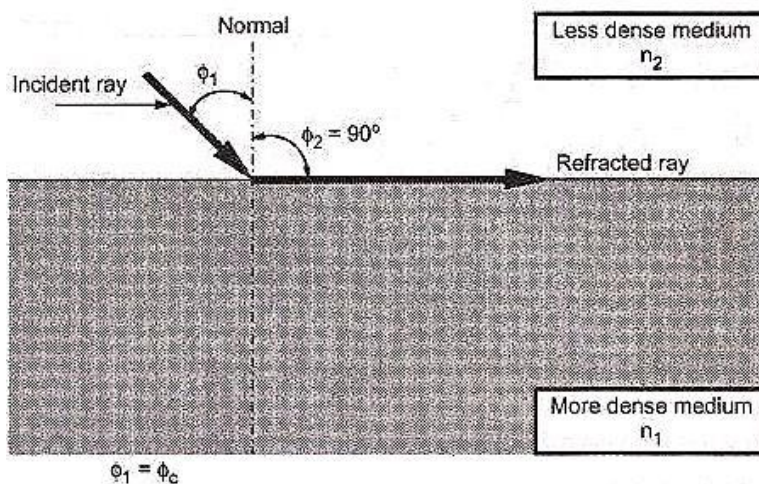

Fig: Critical Angle

Here, at critical angle, $\theta_1 = \theta_c$ and $\theta_2 = 90^\circ$
 Using Snell's law, $n_1 \sin \theta_1 = n_2 \sin \theta_2$

$$\sin \theta_c = \frac{n_2}{n_1} \sin 90^\circ = \sin \theta_c = \frac{n_2}{n_1} \quad \because \sin 90^\circ = 1$$

 Therefore, the critical angle is given by,

$$\text{Critical Angle, } \theta_c = \sin^{-1} \frac{n_2}{n_1}$$

Total Internal Reflection

- "When the light travels from a medium of higher refractive index to a medium of lower refractive index and it strikes the boundary at more than the critical angle, all the light will be reflected back to the incident medium, which means it will not penetrate the second medium". The phenomenon is called "**Total Internal Reflection**".
- Conditions for the total internal reflection are:

- (1) Light should travel from high refractive index material to lower refractive index material.
- (2) Incident angle should be greater than the critical angle.

- Total Internal Reflection can be observed only in materials in which the velocity of light is less than in air.
- The two conditions necessary for Total Internal Reflection to occur are :
 - The refractive index of first medium must be greater than the refractive index of second one.
 - The angle of incidence must be greater than (or equal to) the critical angle.

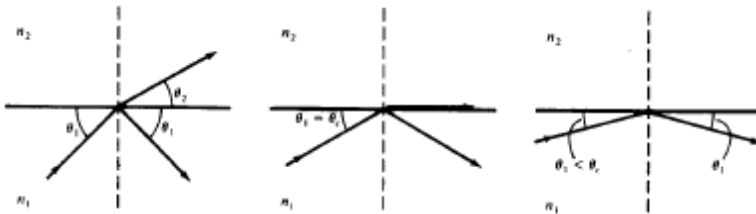

Fig: Representation of critical angle and total internal reflection at the glass-air interface

- If the angle of incidence θ_1 is decreased, a point will eventually be reached where the light ray in air is parallel to the glass surface.
- This point is known as the critical angle of incidence θ_c . When the incident angle θ_1 is less than the critical angle, the condition for internal reflection is satisfied; that is, the light is totally reflected back into the glass with no light escaping from the glass surface.

Numerical Aperture

- The **numerical aperture (NA)** of a fiber is a figure of merit which represents its light gathering capability. Larger the numerical aperture, the greater the amount of light accepted by fiber.
- The acceptance angle also determines how much light is able to be enter the fiber and hence there is relation between the numerical aperture and the cone of acceptance.
- The rays striking the core-cladding interface at angles less than θ_{min} will refract out of the core and be lost in the cladding.

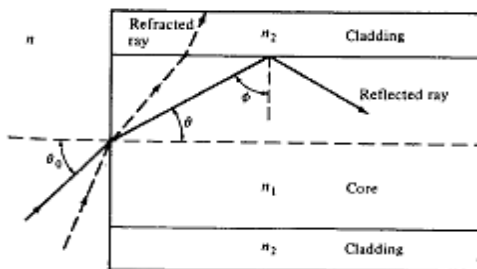

Fig: Meridional Ray optic representation of the propagation mechanism

- By the formula of NA note that the numerical aperture is effectively dependent only on refractive indices of core and cladding material. NA is not a function of fiber dimension.
- The numerical aperture is a dimensionless quantity which is less than unity, with values normally ranging from 0.14 to 0.50.
- Also, the acceptance angle can be calculated by using the formula,

$$\text{Acceptance angle } \theta_0 = \sin^{-1} \text{ Numerical Aperture}$$

- The Cone of acceptance is the angle within which the light is accepted into the core and is able to travel along the fiber. The launching of light wave becomes easier for large acceptance cone.

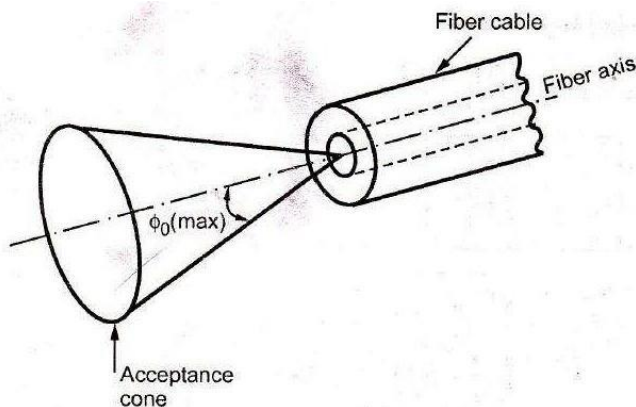

Fig: Acceptance Cone of Optic Fiber

- The angle is measured from the axis of the positive cone so the total angle of convergence is actually twice the stated value

Types of Rays

- If the rays are launched within core of acceptance can be successfully propagated along the fiber. But the exact path of the ray is determined by the position and angle of ray at which it strikes the core.
- There exist three different types of rays.
 - i) Skew ray
 - ii) Meridional rays
 - iii) Axial rays.
- **The skew ray does** not pass through the center, as show in Fig.(a) shown below. The skew rays reflects off from the core cladding boundaries and again bounces around the outside of the core. It takes somewhat similar shape of spiral of helical path.

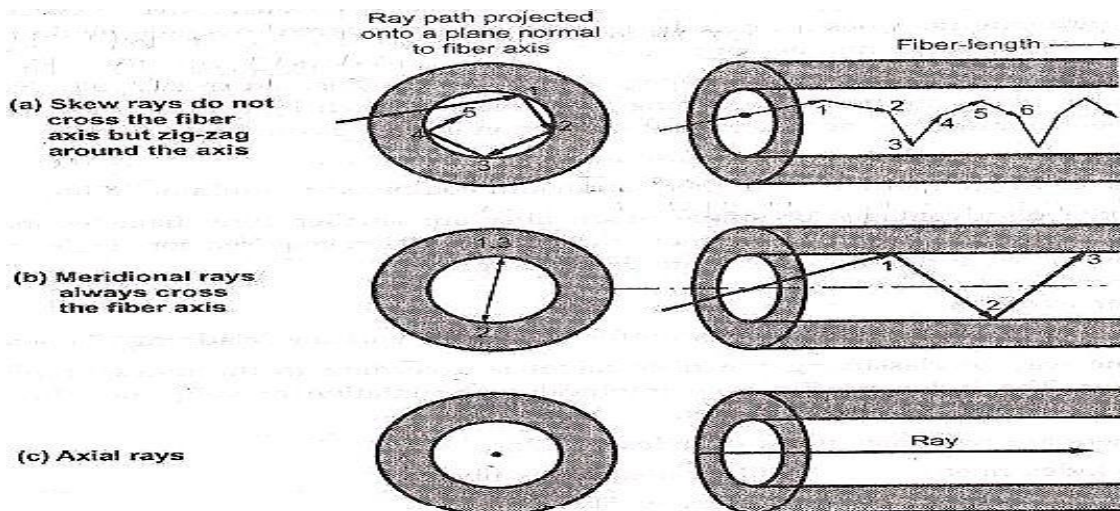

Fig: Different Ray Propagation

- The **meridional** ray enters the core and passes through its axis. When the core surface is parallel, it will always be reflected to pass through the fiber. The meridional ray is shown in fig. (b).
- The **axial ray** travels along the axis of the fiber and stays at the axis all the time. It is shown in fig. (c).

Optical fiber structures with neat sketch:

- The basic structure of an optical fiber consists of three parts; the core, the cladding and the coating or buffer. The basic structure of an optical fiber is shown on figure below.

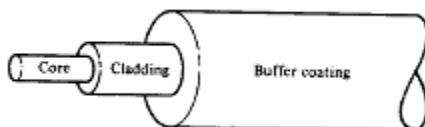

Fig: Structure of a single Fiber

- The core is a cylindrical rod of dielectric material. Dielectric material conducts no electricity. Light propagates mainly along the core of the fiber. The core is generally made of glass. The core is described as having a radius of 'a' and an index of refraction 'n1'.
- The core is surrounded by a layer of material called the cladding. Even though light will propagate along the fiber core without the layer of cladding material, the cladding does perform some necessary functions.
- The cladding layer is made of a dielectric material with an index of refraction 'n2'. The refractive index of the cladding material is less than that of the core material.
- The cladding is generally made of glass or plastic. The cladding performs the following functions:

- Reduces loss of light from the core into the surrounding air
 - Reduces scattering loss at the surface of the core.
 - Protects the fiber from absorbing surface contaminants
 - Adds mechanical strength.
- For extra protection, the cladding is enclosed in an additional layer called the coating or buffer. The coating or buffer is a layer of material used to protect an optical fiber from physical damage. The material used for a buffer is a type of plastic.
 - The buffer is elastic in nature and prevents abrasions. The buffer also prevents the optical fiber from scattering losses caused by microbends. Microbends occur when an optical fiber is placed on a rough and distorted surface.
 - The basic fiber building blocks are used to form large cable. These units are bound on a buffer material which acts as strength element along with insulated copper conductor. The fiber building blocks are surrounded by paper tape, PVC jacket, yarn and outer sheath.

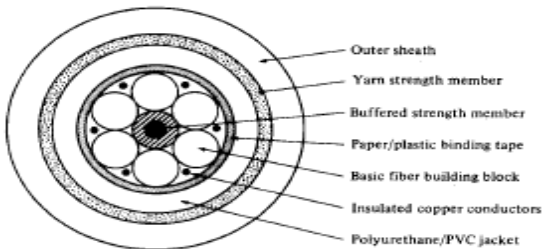

Fig: Six Fiber cable

Fiber Optic Cable Ducts

Number of cores is bundled in plastic ducts. To ease identification, individual fibers are color coded Table below shows an example of the color coding used by manufacturers.

Fiber number Color

Fiber Number	Color
1	Blue
2	Orange
3	Green
4	Brown
5	Grey
6	White
7	Red
8	Black
9	Yellow
10	Violet
11	Pink or Light blue
12	Turquoise or Neutral

Optical Fiber types

- Variations in the material composition of the core give rise to the two commonly used fibertypes shown in figure below: In the first case the refractive index of the core is uniform throughout and undergoes an abrupt change (or step) at the cladding boundary. This is called **step-index fiber**.
- The core typically has diameter of 50-80 μm and the cladding has a diameter of 125 μm .
- The refractive index profile of the step-index fiber is defined as,

$$n_r = \begin{cases} n_1 & \text{where } r < a \text{ (core)} \\ n_2 & \text{where } r \geq a \text{ (cladding)} \end{cases}$$

- Second case the core refractive index is made to vary as a function of the radial distance from the center of the fiber. This type is a **graded-index fiber**.

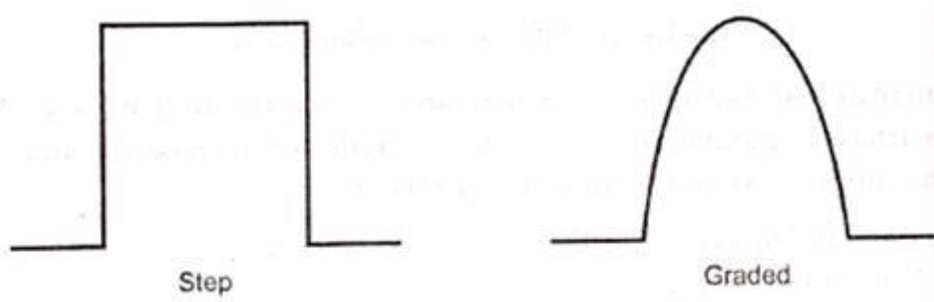

Fig: Index Profile

- The refractive index profile across the core takes the parabolic nature as shown in figure above.
- A graded index fiber has lower coupling efficiency and higher bandwidth than the step index fiber. It is available in 50/125 and 62.5/125 sizes. The 50/125 fiber has been optimized for long haul applications and has a smaller NA and higher bandwidth. 62.5/125 fiber is optimized for LAN applications which is costing 25% more than the 50/125 fiber cable.
- The refractive index variation in the core is given by relationship

$$n_r = \begin{cases} n_1 \left(1 - 2\Delta \frac{r^\alpha}{a}\right) & \text{when } r < a \text{ (core)} \\ n_2 (1 - 2\Delta)^{1/2} \approx n_2 & \text{when } r \geq a \text{ (cladding)} \end{cases}$$

Where, r- Radial distance from fiber axis

a- Core radius

n_1 - Refractive index of core

n_2 - Refractive index of core

α - Shape of index profile

- Profile parameter α determines the characteristic refractive index profile of fiber core.
- The range of refractive index as variation of α is shown in Figure below.

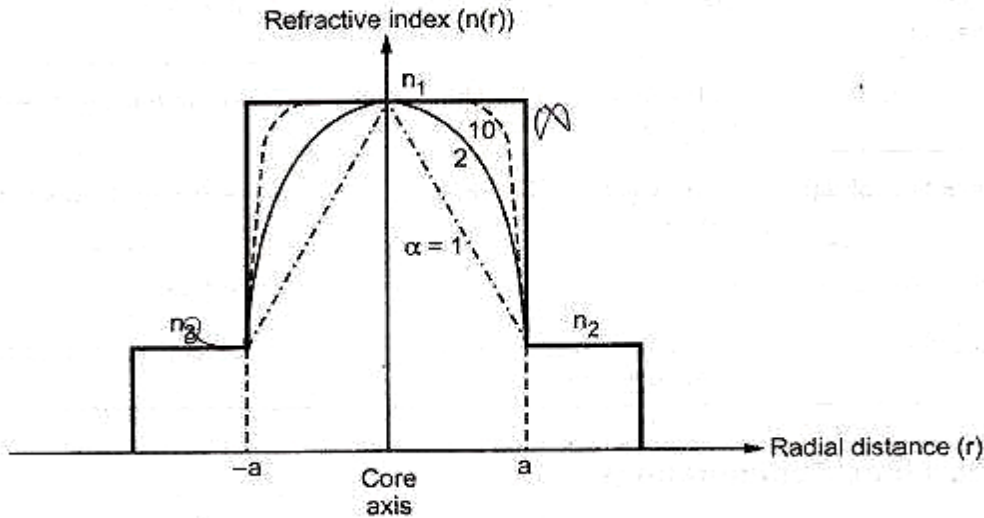

Fig: Possible fiber refractive index profiles for different values of α

- Both Step and graded-index fibers can be further divided into **single mode** and **multimode** classes. Single Mode fiber sustains only one mode of propagation, whereas multimode fibers contain many hundreds of modes.

Name of the subject: MICROWAVE AND OPTICAL ENGINEERING		Sub Code: EC T-7
Name of the Faculty: N.SASIKALA		Yr/Sem/Sec: IV/VII.
Date:	Day:	Hour: 5

Single Mode Fibers

- Single mode fiber allows propagation to light ray by only one path.
- The core size of single mode fibers is small. The core size (diameter) is typically around 8 to 12 micrometers.
- A fiber core of this size allows only the fundamental or lowest order mode to propagate only one mode, because the core size approaches the operational wavelength. The value of the normalized frequency parameter relates core size with mode propagation.
- In single mode fibers, the frequency is less than or equal to 2.405. When the frequency and wavelength 2.405, single mode fibers propagate the fundamental mode down the fiber core, while high-order mode are lost in the cladding.
- For low frequency values, most of the power is propagated in the cladding material. Power transmitted by the cladding is easily lost at the fiber ends. The value of frequency should remain near the 2.405 level.
- Single mode fibers have a lower signal loss and a higher information capacity (bandwidth) than multimode fibers. Single mode fibers are capable of transferring higher amounts of data to low fiber dispersion.
- In single mode fibers, the wavelength can increase or decrease the losses caused by fiber bending.
- They lose power because light radiates into cladding, which is lost at fiber bends. In general, single mode fibers are considered to be low-loss fibers which increase

system bandwidth and length.

- Some disadvantages of single mode fiber are smaller core diameter makes coupling light into the core more difficult.

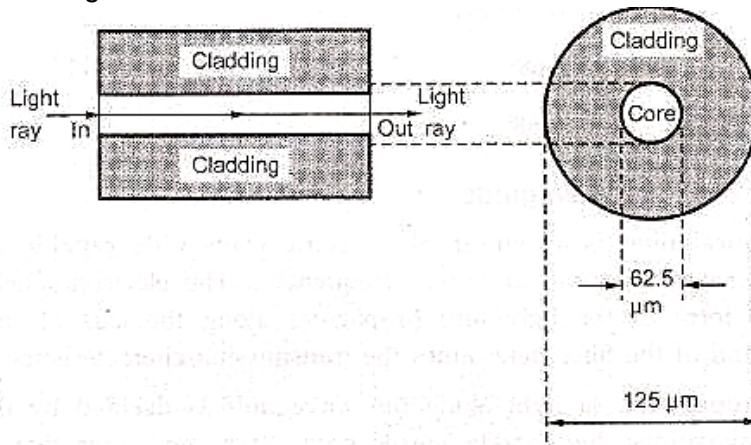

Fig: Single Mode Propagation Multimode Fibers

- The term multimode simply refers to the fact that numerous modes (light rays) are carried simultaneously through the waveguide. Multimode fiber has a much larger diameter, compared to single mode fiber; this allows large number of modes.
- Another advantage is that multimode fibers permit the use of light emitting diodes (LEDs). Single mode fibers typically must use laser diodes. LEDs are cheaper, less complex and last longer. LEDs are preferred for most applications.
- The disadvantage is that multimode fibers suffers from intermodal dispersion

Optic Fiber Configurations

Depending on the refractive index profile of fiber and modes of fiber there exist three types of optical fiber configurations. These optic-fiber configurations are -

- i) Single mode step index fiber.
- ii) Multimode step index fiber.
- iii) Multimode graded index fiber

Single mode Step index Fiber

- Single mode step index fiber has a central core that is sufficiently small so that there is essentially only one path for light ray through the cable. The light ray is propagated in the fiber through reflection.
- Typical core sizes are 8 to 12μm.
- Single mode fiber is also known as fundamental or monomode fiber.
- Single mode fiber will permit only one mode to propagate and does not suffer from mode delay differences. These are primarily developed for the 1300 nm window but they can be also be used effectively with time division multiplex (TDM) and wavelength division multiplex (WDM) systems operating in 1550 nm wavelength region.

- The core fiber of a single mode fiber is very narrow compared to the wavelength of light being used. Therefore, only a single path exists through the cable core through which light can travel.
- The disadvantage of this type of cable is that because of extremely small size interconnection of cables and interfacing with source is difficult.
- Another disadvantage of single mode fibers is that as the refractive index of glass decreases with optical wavelength, the light velocity will also be wavelength dependent. Thus the light from an optical transmitter will have definite spectral width.

Multimode step Index Fiber

- diameter is 50 to 1000 μm i.e. large aperture and allows more light to enter the cable. The light rays are propagated down the core in zig-zag manner.
- There are many paths that a light ray may follow during the propagation.
- The light ray is propagated using the principle of total internal reflection. Since the core index of refraction is higher than the cladding index of refraction, the light enters at less than critical angle is guided along the fiber.
- Light rays passing through the fiber are continuously reflected off the glass cladding towards the center of the core at different angles and lengths, limiting overall bandwidth.
- The disadvantage of multimode step index fibers is that the different optical length caused by various angles at which light is propagated relative to the core, causes the transmission bandwidth to be fairly small. Because of these limitations, multimode step index fiber is typically only used in applications requiring distances of less than 1 km. **Multimode step index fiber** is more widely used type. It is easy to manufacture. Its core

Multimode Graded Index Fiber

- The core size of **multimode graded index fiber** cable is varying from 50 to 100 μm range.
- The light ray is propagated through the refraction. The light ray enters the fiber at many different angles.
- As the light propagates across the core toward the center it is intersecting a less dense to more dense medium.
- Therefore the light rays are being constantly being refracted and ray is bending continuously. This cable is mostly used for long distance communication.

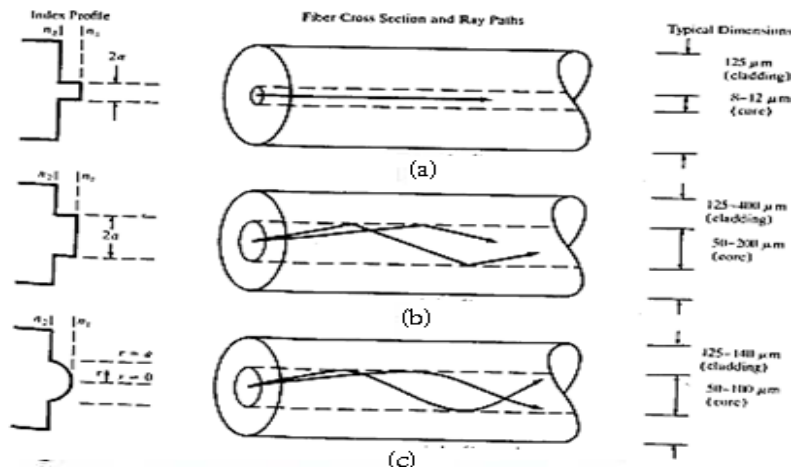

Fig (a) Single mode step index Fiber (b) Multimode Step-index Fiber (c) Multimode graded-index Fiber

- The light rays no longer follow straight lines; they follow a serpentine path being gradually bent back towards the center by the continuously declining refractive index.
- The modes travelling in a straight line are in a higher refractive index so they travel slower than the serpentine modes. This reduces the arrival time disparity because all modes arrive at about the same time.
- Figure below shows the light trajectory in detail. It is seen that light rays running close to the fiber axis with shorter path length, will have a lower velocity because they pass through a region with a high refractive index.
- Rays on core edges offers reduced refractive index, hence travel more faster than axial rays and cause the light components to take same amount of time to travel the length of fiber, thus minimizing dispersion losses.
- Each path at a different angle is termed as '**transmission mode**' and the NA of graded index fiber is defined as the maximum value of acceptance angle at the fiber axis.
- Typical attenuation coefficients of graded index fibers at 850 nm are 2.5 to 3 dB/km, while at 1300 nm they are 1.0 to 1.5 dB/km.
- The main advantages of graded index fiber are:
 - Reduced refractive index at the center of core.
 - Comparatively cheap to produce.

Optical losses and brief square losses:

Introduction

The signal attenuation of fiber determines the maximum distance between transmitter and receiver. The attenuation also determines the number of repeaters required, maintaining repeater is a costly affair.

Attenuation

- Attenuation of a light as it propagates along a fiber is an important consideration in the design of an optical communication system in determining the maximum transmission distance between a transmitter and a receiver.
- Attenuation in an optical fiber is caused by absorption, scattering and bending losses.
- Absorption is related to the fiber material, whereas scattering is associated both with the fiber material and with structural imperfections in the optical waveguide.
- Scattering due to structuralism perfection within the fiber. Nearly 90 % of total attenuation is caused by Rayleigh scattering only.
- The Rayleigh scattering is wavelength dependent and reduces rapidly as the wavelength of the incident radiation increases.
- Micro bending of optical fiber also contributes to the attenuation of signal.

Attenuation Units

- Signal attenuation (or fiber loss) is defined as the ratio of the optical output power P_{out} from a fiber of length L to the optical input power P_{in} .
- This power ratio is a function of wavelength. The symbol α is commonly used to express attenuation in decibels per kilometer (dB/Km).

$$\alpha = \frac{10}{L} \log \frac{P_{in}}{P_{out}}$$

Absorption

- Absorption is caused by three different mechanisms:
- Absorption by atomic defects in the glass composition
- Extrinsic absorption by impurity atoms in the glass material
- Intrinsic absorption by the basic constituent atoms of the fiber material.
- Atomic defects are imperfections of the atomic structure of the fiber material such as missing molecules, high-density clusters of atom groups or oxygen defects in the glass structure.
- Usually absorption losses arising from these defects are negligible compared to intrinsic and impurity absorption effects.
- The absorption effect is most significant when fiber is exposed to ionizing radiation in nuclear reactor, medical therapies, space missions etc. The radiation damages the internal structure of fiber. The damages are proportional to the intensity of ionizing particles. This results in increasing attenuation due to atomic defects and absorbing optical energy.
- The total dose a material receives is expressed in rad (Si), this is the unit for measuring radiation absorbed in bulk silicon.

$$1 \text{ rad (Si)} = 0.01 \text{ J.kg}$$

- The higher the radiation intensity more the attenuation as shown in Fig shown below:

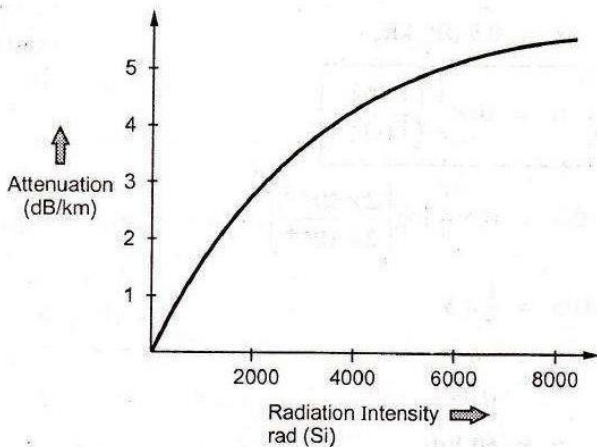

Fig: Ionizing Radiation intensity Vs Fiber Attenuation

Intrinsic Absorption

- Intrinsic absorption is associated with the basic fiber material and is the principal physical factor that defines the transparency window of a material over a specified spectral region.
- It occurs when the material is in a perfect state with no density variations, impurities, material in homogeneities, etc.,
- Intrinsic absorption thus sets the fundamental lower limit on absorption for any particular material.

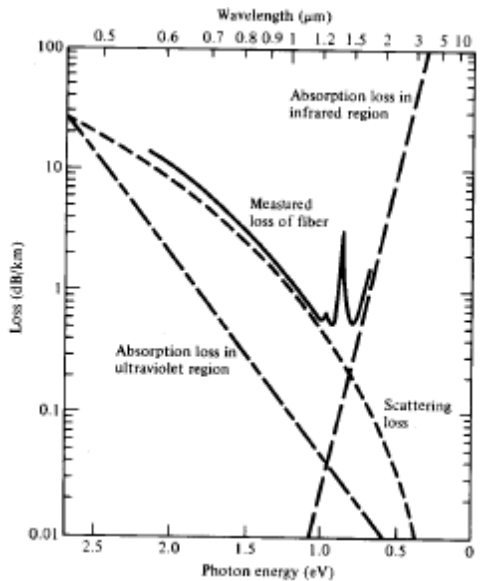

Fig: Optical Fiber Attenuation Characteristics

- Intrinsic absorption results from electronic absorption bands in the ultraviolet region

and from atomic vibration bands in the near infrared region. The electronic absorption bands are associated with the band gaps of the amorphous glass materials.

- Absorption occurs when a photon interacts with an electron in the valence band and excites it to a higher energy level.
- The magnitude and characteristic exponential decay of the ultraviolet absorption is shown in figure:
- The ultraviolet loss is small compared to scattering loss in the near infrared region.

Extrinsic Absorption

- Extrinsic absorption occurs due to electronic transitions between the energy level and because of charge transitions from one ion to another.
- A major source of attenuation is from transition of metal impurity ions such as iron, chromium, cobalt and copper. These losses can be upto 1 to 10 dB/km. The effect of metallic impurities can be reduced by glass refining techniques.
- Another major extrinsic loss is caused by absorption due to **OH (Hydroxyl)** ions impurities dissolved in glass. Vibrations occur at wavelengths between 2.7 and 4.2 μm .
- The absorption peaks occurs at 1400, 950 and 750 nm. These are first, second and third overtones respectively.
- Figure below shows absorption spectrum for OH group in silica. Between these absorption peaks there are regions of low attenuation.

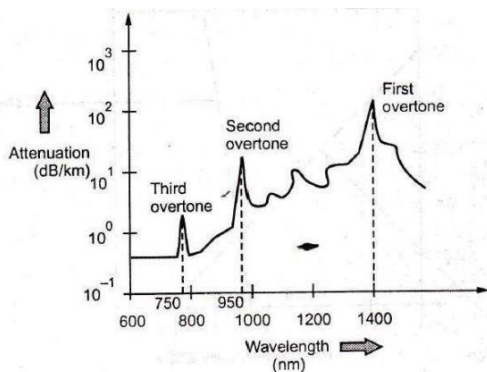
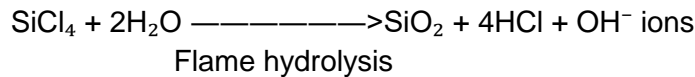

Fig: Absorption Spectra for OH group

- These absorption peaks define three regions or windows of preferred operation. The first window is centered at 850 nm. The second window is centered at 1300 nm. The third window is centered at 1550 nm. Fiber optic systems operate at wavelengths defined by one of these windows.
- The amount of water(OH-) impurities present in a fiber should be less than a few parts per billion. Fiber attenuation caused by extrinsic absorption is affected by the level of impurities(OH-) present in the fiber. If the amount of impurities in a fiber is reduced, then fiber attenuation is reduced.
- Hydrolysis method is one of the fabrication processes of optical fiber. The streaming materials used in this method are SiCl_4 , GeCl_4 , & PoCl_3 . During hydrolysis process i.e., when these materials used in hydrolysis process, gives OH ions.



Scattering Losses

- A beam propagating at the critical angle will change direction after it meet obstacle. Therefore, the light will be scattered. The scattering effects prevent the attainment of TIR at the core cladding boundary resulting in power loss. This loss is known as SCATTERING LOSS.
- □ Linear scattering losses
- Non-linear scattering losses
- Scattering losses arise from microscopic variations in the material density, from compositional fluctuations, and from structural in homogeneities or defects, occurring during fiber manufacture.
- Scattering losses exists in optical fibers because of microscopic variations in the material density and composition. As glass is composed by randomly connected network of molecules and several oxides (e.g. SiO₂, GeO₂ and P₂O₅), these are the major cause of compositional structure fluctuation.

□ Linear scattering losses:

Linear scattering mechanism causes transfer of optical power from one mode to different mode. This process tend to result on attenuation of the transmitted light as the transfer may be to a leaky mode (or) radiation mode which does not continue to propagate within the fiber . There are two types of linear scattering losses.

1. Rayleigh Scattering
2. Mie Scattering

Rayleigh Scattering

- Rayleigh scattering in glass is the same phenomenon that scatters light from the sun in the atmosphere, thereby giving rise to a blue sky.
- Rayleigh scattering of light is due to small localized changes in the refractive index of the core and cladding material. There are **two causes** during the manufacturing of fiber.
- The first is due to slight fluctuation in mixing of ingredients. The random changes because of this are impossible to eliminate completely.
- The other cause is slight change in density as the silica cools and solidifies. When light ray strikes such zones it gets scattered in all directions. The amount of scatter depends on the size of the discontinuity compared with the wavelength of the light so the shortest wavelength (highest frequency) suffers most scattering.
- The expressions for scattering induced attenuation are fairly complex owing to the random molecular nature and the various oxide constituents of glass.
- For single component glass the scattering loss at a wavelength λ resulting from

density fluctuations can be approximated by,

$$\alpha_{scat} = \frac{8\pi^3}{3\lambda^4} n^2 - 1^2 k_B T_f \beta_T$$

$$\alpha_{scat} = \frac{8\pi^3}{3\lambda^4} n^8 p^2 k_B T_f \beta_T$$

Where, p is the photo-elastic coefficient

For Multicomponent glasses the scattering is given by,

$$\alpha = \frac{8\pi^3}{3\lambda^4} \delta n^2 \delta V$$

Figure below shows graphically the relationship between wavelength and Rayleigh scattering loss.

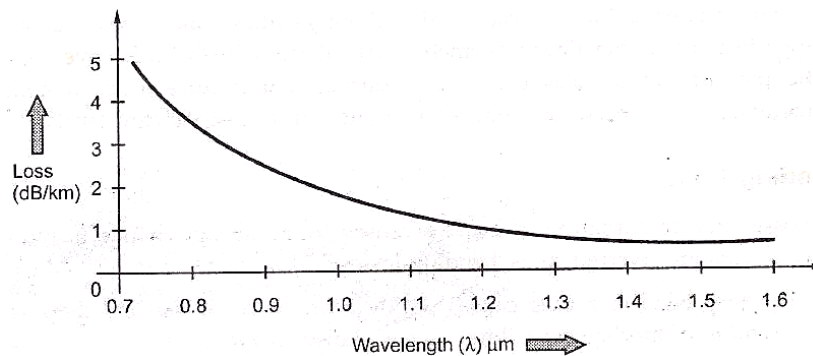

Fig: Scattering Loss

Mie Scattering

Linear scattering also occurs at inhomogeneities and these arise from imperfections in the fiber's geometry, irregularities in the refractive index and the presence of bubbles etc. caused during manufacture. Careful control of manufacturing process can reduce mie scattering to insignificant levels.

Bending Loss

- Radiative losses occur whenever an optical fiber undergoes a bend of finite radius of curvature.
- Fibers can subject to two types of bends: **(a)** microscopic bends having radii that are large compared to the fiber diameter for example, such as occur when a fiber cable

turns a corner and **(b)** random microscopic bends of the fiber axis that can arise when the fibers are incorporated into cables.

- The sharp bend of a fiber causes significant radiative losses and there is also possibility of mechanical failure. This is shown in Figure below:

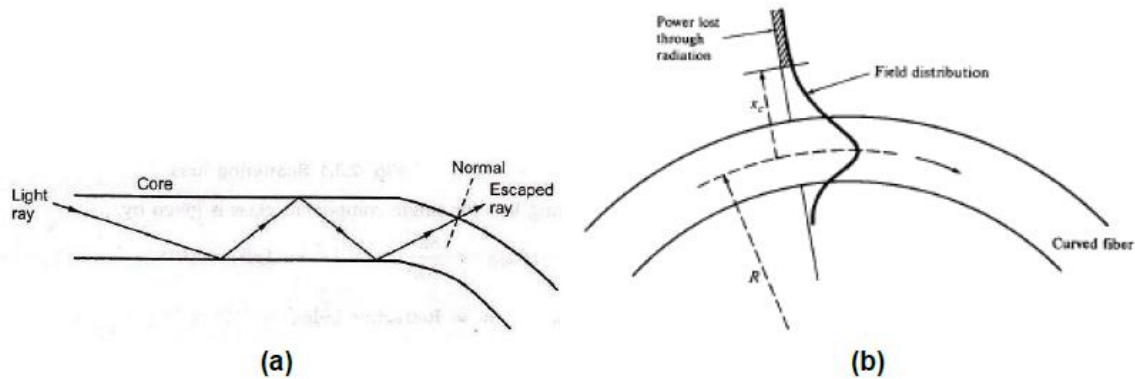

Figure: Bending Loss

- As the core bends the normal will follow it and the ray will now find itself on the wrong side of critical angle and will escape. The sharp bends are therefore avoided.
- The radiation loss from a bent fiber depends on –
- Field strength of certain critical distance x_c from fiber axis where power is lost through radiation.
- The radius of curvature R .
- The higher order modes are less tightly bound to the fiber core, the higher order modes radiate out of fiber firstly.
- For multimode fiber, the effective number of modes that can be guided by curved fiber is given expression :

$$N_{eff} = N_{\infty} \left[1 - \frac{\alpha + 2}{2\alpha\Delta} \frac{2a}{R} + \frac{3}{2n_2 k R} \right]^{2/3}$$

Micro bend Loss

- Micro bends are due to small-scale fluctuations in the radius of curvature of the fiber axis, as shown in figure.
- They are caused either by non-uniformities in the manufacturing of the fiber or by non-uniform lateral pressures created during the cable of the fiber.
- An increase in attenuation results from micro bending because the fiber curvature causes repetitive coupling of energy between the guided mode and the leaky or non-guided modes in the fiber.
- One method of minimizing micro bending losses is by extruding a compressible jacket

over the fiber. When the external forces will tend to stay relatively straight, as shown in figure below.

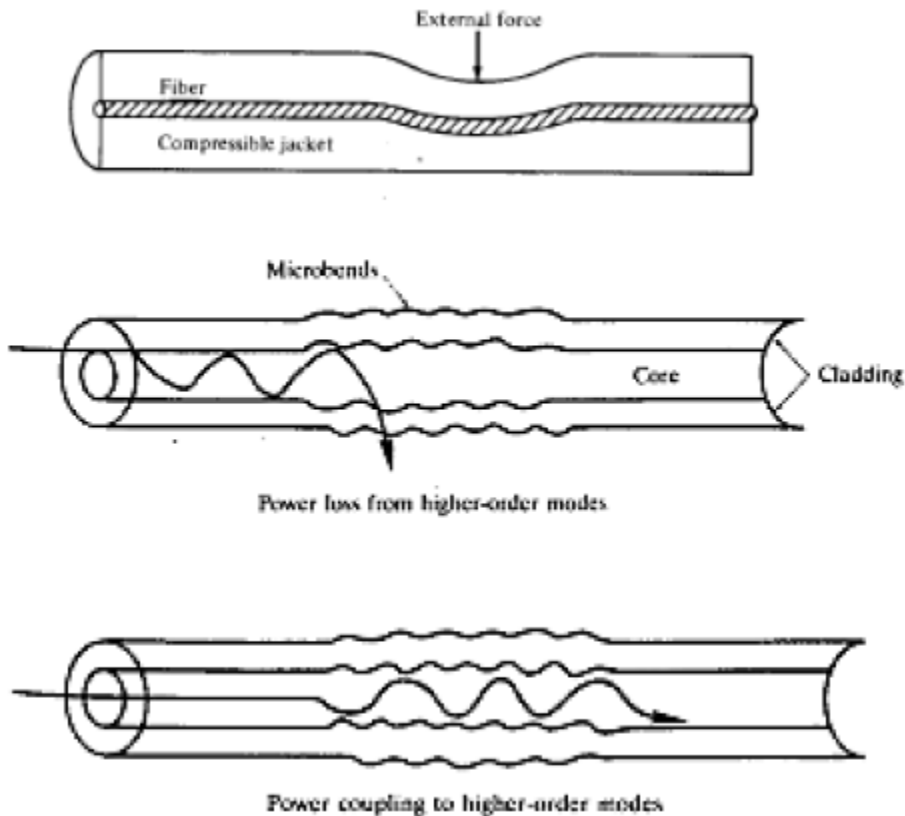

Figure: Micro bending Losses

- For multimode graded-index fiber having a core radius a , outer radius b (excluding the jacket), and index difference Δ , the micro bending loss of a jacket is reduced from that of an unjacketed fiber by a factor

$$F \alpha_M = 1 + \pi \Delta^2 \frac{b^4 E_f}{a C}^{-2}$$

- Here, E_f and C are the Young's moduli of the fiber and jacket respectively. The Young's modulus of common jacket materials ranges from 20 to 500 MP and the Young's modulus of fused silica glass is about 65 GPa.

Macro Bending Loss

- The change in spectral attenuation caused by macro bending is different to micro bending. Usually there are no peaks and troughs because in a macro bending no light is coupled back into the core from the cladding as can happen in the case of microbends.

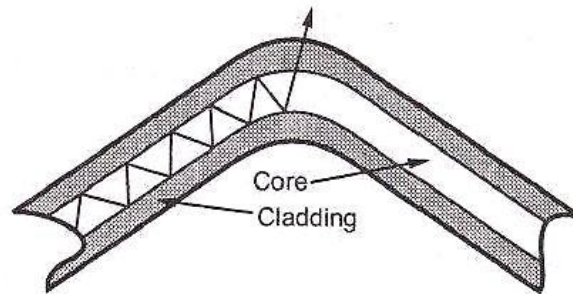

Figure: MacroBending Loss

Dispersion in optical fiber :

- An optical signal becomes increasingly distorted as it travels along a fiber. This distortion is due to the effects of **intramodal** dispersion and **intermodal** delay effects. These distortion effects can be explained by examining the behavior of the group velocities of the guided modes, where the group velocity is the speed at which energy in a particular mode travels along the fiber.
- **Intramodal Dispersion**
- Intramodal Dispersion is pulse spreading that occurs within a single mode. It is a result of the group velocity being a function of the wavelength λ .
- It depends on the wavelength, its effect on signal distortion increases with the spectral width of the optical source. This spectral width is the band of wavelengths over which the source emits light.
- For LEDs the rms spectral width is approximately 5 % of a central wavelength. Laser diode optical sources have much narrower spectral widths, typical values being 1 to 2 nm.
- The two main causes of intramodal dispersion are:

1. Material Dispersion:

- Material Dispersion, which arises from the variation of the refractive index of the core material as a function of wavelength. It is also referred to as chromatic P. Arunagiri, Assistant Professor, Department of ECE, Sri Manakula Vinayagar Engineering College
- dispersion or spectral dispersion. This causes a wavelength dependence of the group velocity of any given mode; that is pulse spreading occurs even when different wavelengths follow the same path.

2. Wavelength Dispersion:

- Wavelength dispersion, occurs because a single-mode fiber only confines about 80 % of the optical power to the core.
- Dispersion thus arises, since the 20 % of the light propagating in the cladding travels

faster than the light confined to the core.

- The amount of waveguide dispersion depends on the fiber design, since the modal propagation constant β is a function of a/λ , (where λ is the wavelength and a is the core radius.)
- Dispersion and attenuation of pulse travelling along the fiber is shown in figure below.

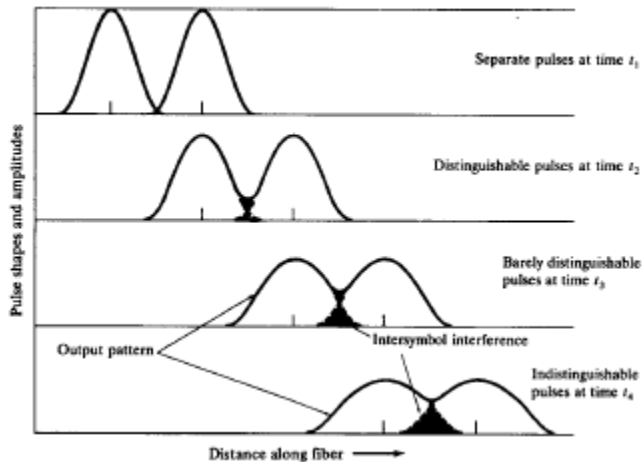

Figure: Broadening and spreading of two adjacent pulses as they travel along fiber

- Figure above shows, after travelling some distance, pulse starts broadening and overlap with the neighboring pulses. At certain distance the pulses are not even distinguishable and error will occur at receiver. Therefore the information capacity is specified by **bandwidth distance product** (MHz * km). For step index bandwidth distance product is 20 MHz*km and for graded index it is 2.5 MHz*km.
- The information carrying capacity can be determined by examining the deformation of short light pulses propagating along the fiber.

Group Delay

- Consider a fiber cable carrying optical signal equally with various modes and each mode contains all the spectral components in the wavelength band.
- All the spectral components travel independently and they observe different **time delay** and **group delay** in the direction of propagation. The group delay per unit length in the direction of propagation is given by,

$$\frac{\tau_g}{L} = \frac{1}{V_g} = \frac{1}{c} \frac{d\beta}{dk} = -\frac{\lambda^2}{2\pi c} \frac{d\beta}{d\lambda}$$

- The velocity at which the energy in a pulse travels along the fiber is known as **group velocity**. Group velocity is given by,

$$V_g = c \cdot \frac{d\beta}{dk}^{-1}$$

- The group delay depends on the wavelength, each spectral component of any particular mode takes a different amount of time to travel a certain distance. As a result of this difference in time delays, the optical signal pulse spreads out with time as it is transmitted over the fiber. Thus it also depends on pulse spreading.
- Thus, the dispersion is defined as the pulse spread as a function of wavelength. It is measured in picoseconds per kilometer per nanometer. It is expressed as,

$$D = \frac{1}{L} \frac{d\tau_g}{d\lambda}$$

Material Dispersion

- Material dispersion is also called as chromatic dispersion. Material dispersion exists due to change in index of refraction for different wavelengths. The group velocity V_g of a mode is a function of the index of refraction, the various spectral components of a given mode will travel at different speeds, depending on the wavelength.
- Material dispersion is an intramodal dispersion effect, and is of particular importance for single-mode waveguides and for LED systems.
- By considering a plane wave propagating in an infinity extended medium that has a refractive index $n(\lambda)$ equal to that of the fiber core.

The propagation constant is thus given by,

$$\beta = \frac{2\pi n(\lambda)}{\lambda}$$

The group delay can be written by substituting the value of β

$$\tau_{Mat} = \frac{L}{c} \left(n - \lambda \frac{dn}{d\lambda} \right)$$

The material dispersion for unit length ($L = 1$) is given by,

$$D_{Mat} = \frac{-\lambda}{c} \times \frac{d^2n}{d\lambda^2}$$

Figure below shows index of refraction as a function of optical wavelength

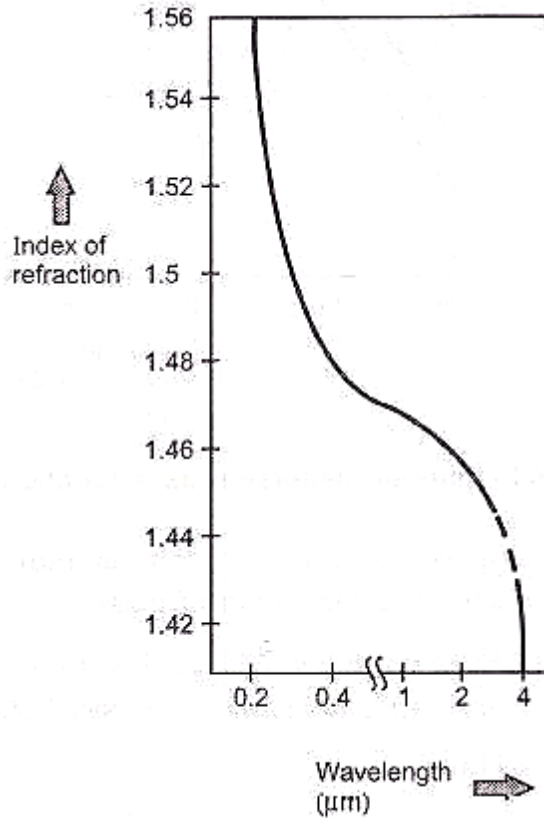

Fig: Index of refraction as a function of wavelength

Figure below shows the variation of material dispersion as a function of wavelength

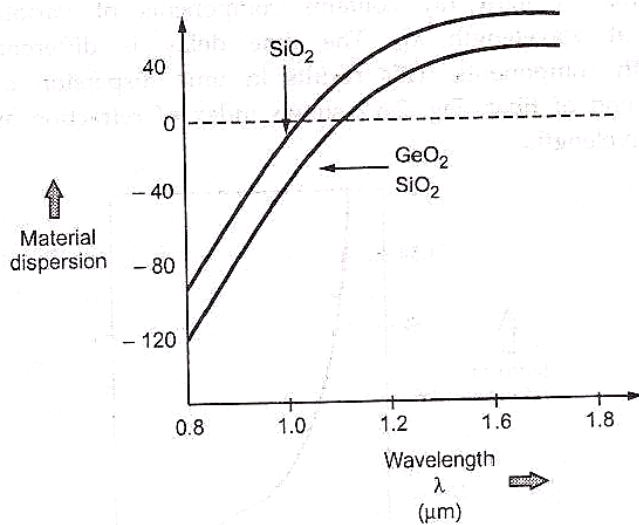

Fig: Material Dispersion as a function of wavelength

- From the figure we understand that the amount of material dispersion depends upon the chemical composition of glass.

Waveguide Dispersion

- Waveguide dispersion is caused by the difference in the index of refraction between the core and cladding, resulting in a 'drag' effect between the core and cladding portions of the power.
- Waveguide dispersion is significant only in fibers carrying fewer than 5-10 modes. Since multimode optical fibers carry hundreds of modes, they will not have observable waveguide dispersion.

The group delay (τ_{wg}) arising due to waveguide dispersion.

$$\tau_{wg} = \frac{L d\beta}{c dk} = \frac{L}{c} n_2 + n_2 \Delta \frac{d(kb)}{dk}$$

For small values of V instead of k in group delay yields,

$$\tau_{wg} = \frac{L d\beta}{c dk} = \frac{L}{c} n_2 + n_2 \Delta \frac{d(Vb)}{dk}$$

The first term is constant and the second term is group delay arising from waveguide dispersion.

- **The mechanism of intermodal dispersion in multimode step index fiber:**
- Single-mode fibers waveguide dispersion is of importance and can be of the same order of magnitude as material dispersion.
- The pulse spread occurring over a distribution of wavelengths is obtained from the derivative of the group delay with respect to wavelength,

$$\begin{aligned} \sigma_{wg} &= \sigma_\lambda \frac{d\tau_{wg}}{d\lambda} = \sigma_\lambda L D_{wg}(\lambda) \\ &= -\frac{V}{\lambda} \sigma_\lambda \frac{d\tau_{wg}}{dV} = -\frac{n_2 L \Delta \sigma_\lambda}{c \lambda} V \frac{d^2 Vb}{dV^2} \end{aligned}$$

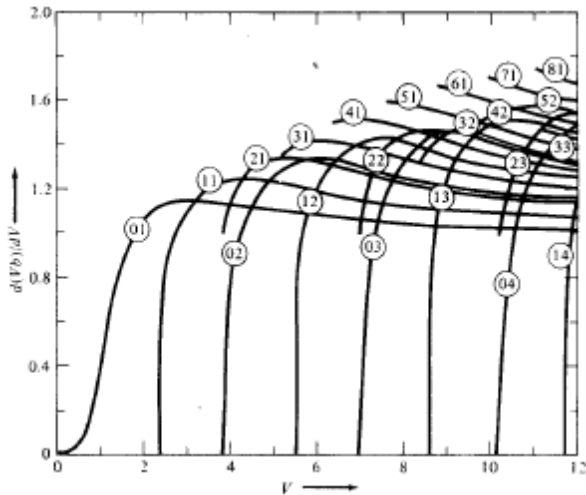

Fig: Group Delay of waveguide dispersion as function of V number of step-index fiber

This factor reaches a maximum at $V=1.2$ but runs between 0.2 and 0.1 for a practical single-mode operating range of $V = 2.0$ to 2.4. thus for values of $\Delta = 0.01$ and $n_2= 1.5$, The figure above shows that fused –silica –core single mode fiber having $V=2.4$

Intermodal Dispersion in single-mode fiber

- The final factor giving rise to signal degradation is intermodal distortion, which is a result of different values of the group delay for each individual mode at a single frequency.
- The variation in the group velocities of the different modes results in a group delay spread or intermodal distortion. This distortion mechanism is eliminated by single-mode operation, but is important in multimode fibers.
- The pulse broadening arising from intermodal distortion is the difference between the travel time of the longest ray congruence paths (the highest-order mode) and the travel time of the shortest ray congruence paths (the fundamental mode). This is simply obtained from ray tracing and is given by,

$$\sigma_{mod} = T_{max} - T_{min} = \frac{n_1 \Delta L}{c}$$

Mode Coupling

- After certain initial length, the pulse distortion increases less rapidly because of mode coupling. The energy from one mode is coupled to other mods because of:
 - Structural imperfections.
 - Fiber diameter variations.
 - Refractive index variations.
 - Microbends in cable.

- Due to the mode coupling, average propagation delay become less and intermodal distortion reduces.
- Suppose certain initial coupling length = L_c , mode coupling length, over $L_c = Z$. Additional loss associated with mode coupling = h (dB/ km). Therefore the excess attenuation resulting from mode coupling = hZ . The improvement in pulse spreading by mode coupling is given as :

$$hZ \frac{\sigma_c}{\sigma_0} = C$$

where, C is a constant, σ_c is the pulse width increase in the absence of mode coupling, σ_0 is the pulse broadening in the presence of strong mode coupling, and hZ is the excess attenuation resulting from mode coupling.

- For long fiber length's the effect of mode coupling on pulse distortion is significant. For a graded index fiber, the effect of distance on pulse broadening for various coupling losses is shown in Figure below.

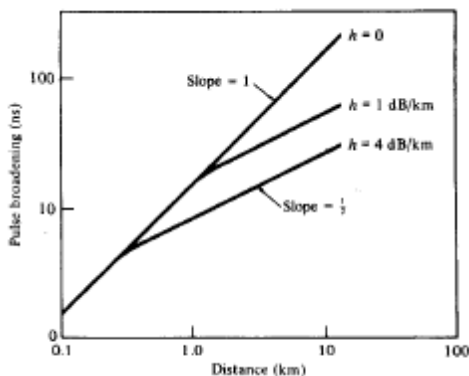

Fig: Mode coupling effects on pulse distortion in long fibers for various coupling losses

Design Optimization

Features of single mode fibers are :

- Longer life.
- Low attenuation.
- Signal transfer quality is good.
- Modal noise is absent.
- Largest BW-distance product.

Basic design – optimization includes the following :

- Cut-off wavelength.
- Dispersion.
- Mode field diameter.
- Bending loss.
- Refractive index profile.

Refractive Index Profile

- Dispersion of single mode silica fiber is lowest at 1300 nm while its attenuation is minimum at 1550 nm. For achieving maximum transmission distance the dispersion null should be at the wavelength of minimum attenuation.
- The waveguide dispersion is easier to control than the material dispersion. Therefore a variety of core-cladding refractive index configuration fibers. Such as 1300 nm – optimized fibers, dispersion shifted fibers, dispersion – flattened fibers and large effective core area fibers.

1300 nm – Optimized Fibers

These are most popularly used fibers. The two configurations of 1300 nm – optimized single mode fibers are :

- Matched cladding fibers.
- Dressed cladding fibers.
- Matched cladding fibers have uniform refractive index throughout its cladding. Typical diameter is $9.0 \mu\text{m}$ and $\Delta = 0.35 \%$.
- Dressed cladding fibers have the innermost cladding portion has low refractive index than outercladding region. Typical diameter is $8.4 \mu\text{m}$ and $\Delta_1 = 0.25 \%$, $\Delta_2 = 0.12 \%$.

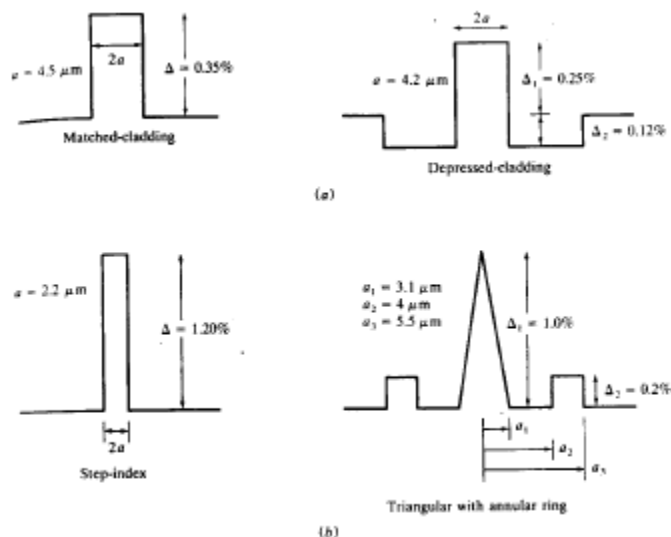

Fig: (a) 1300 nm – Optimized (b) dispersion-shifted

The addition of wavelength and material dispersion can shift the zero dispersion point of longer wavelength. Two configurations of dispersion shifted fibers are :

- Step index dispersion shifted fiber.

- □ Triangular dispersion shifted fiber.

Dispersion Flattened

Dispersion flattened fibers are more complex to design. It offers much broader span of wavelengths to suit desirable characteristics. Two configurations are :

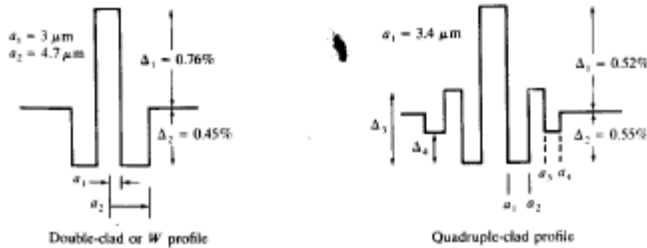

Fig; Dispersion Flattened in single mode fibers

Figure below shows total resultant dispersion.

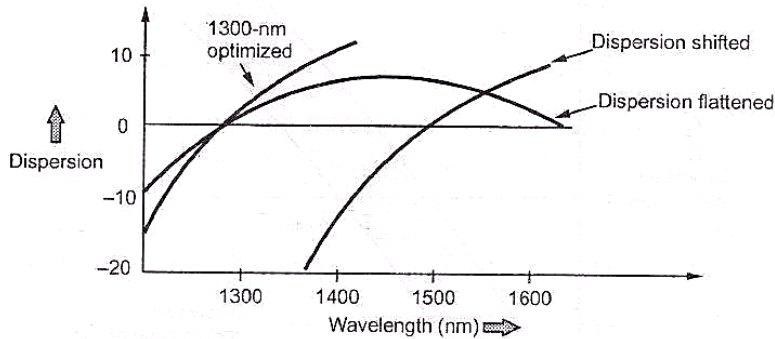

**Fig: Total Resultant Dispersion
Dispersion Calculations**

The total dispersion consists of material and waveguide dispersions. The resultant intermodal dispersion is given as,

$$D_{\lambda} = \frac{d\tau}{d\lambda}$$

The broadening of an optical pulse is given as,

$$\sigma = \bar{D}_{\lambda} L \sigma_{\lambda}$$

As the dispersion varies with wavelength and fiber type. Different formulae are used to calculate dispersions for variety of fiber at different wavelength.

For a non –dispersion shifted fiber between 1270 nm to 1340 nm wavelength, the expression for the dispersion is given as,

$$D_{\lambda} = \frac{\lambda}{4} S_0 \left(1 - \frac{\lambda \sigma^4}{\lambda} \right)$$

Figure below shows dispersion performance curve for non-dispersion shifted fibers in 1270 –

1340 nm region.

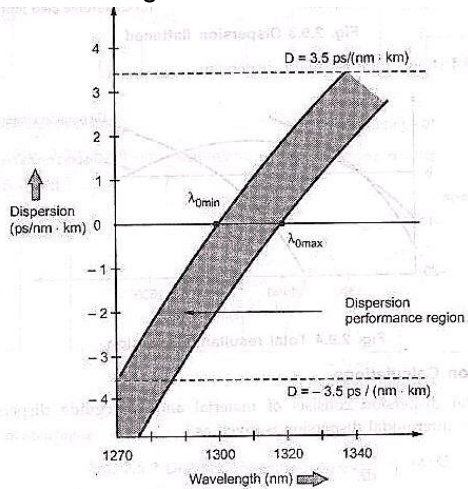

Maximum dispersion specified as 3.5 ps/(nm . km) marked as dotted line.

Cut-off Frequency of an Optical Fiber

The cut-off frequency of an optical fiber is determined not only by the fiber itself (modal dispersion in case of multimode fibers and waveguide dispersion in case of single mode fibers) but also by the amount of material dispersion caused by the spectral width of transmitter.

Bending Loss Limitations

- The macro-bending and microbending losses are significant in single mode fibers at 1550 nm region, the lower cut-off wavelengths affects more. Figure below shows macrobending losses.

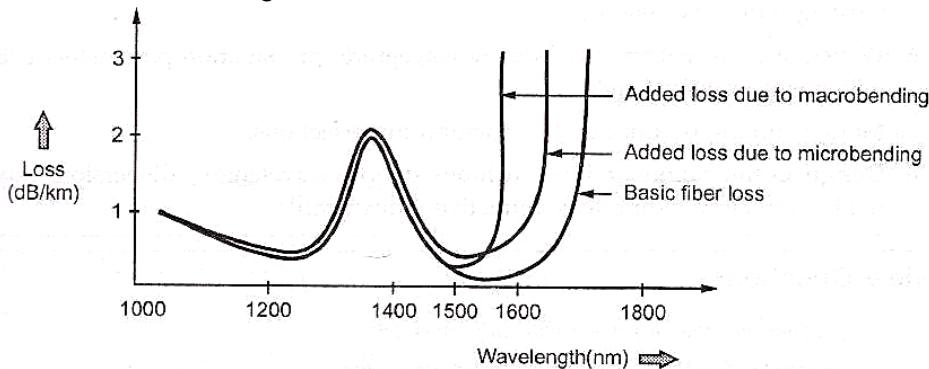
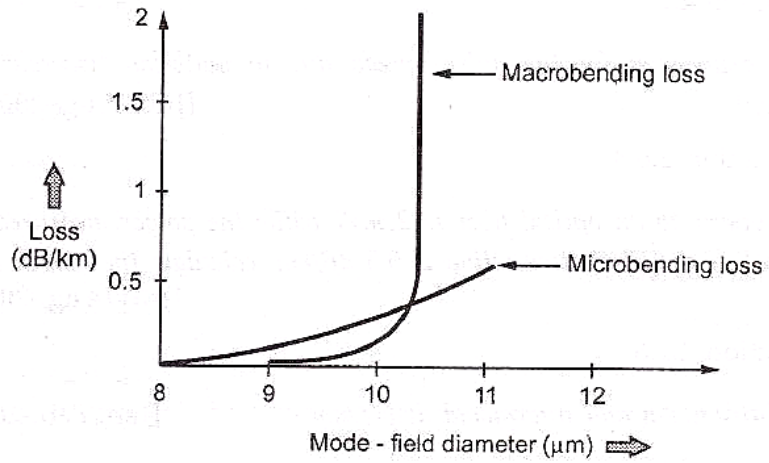

Fig:Fiber attenuation due to microbending and Macro bending Loss

- The bending losses are function of mode-field diameter, smaller the mode-field diameter, the smaller the bending loss. Fig. 2.9.7 shows loss due to mode-field diameter.
- The bending losses are also function of bend-radius of curvature. If the bend radius is less, the losses are more and when the radius is more, the bending losses are less.



Fig; Loss due to mode field variation

- From figure we understand that the smaller the mode field diameter, smaller the bending loss.

UNIT – IV OPTICAL SOURCES, DETECTORS AND AMPLIFIERS

Fiber Optic Communications System

- A fiber optic data link sends input data through fiber optic components and provides as output information. It has the following three basic functions:
 - ✓ To convert an electrical input signal to an optical signal
 - ✓ To send the optical signal over an optical fiber
 - ✓ To convert the optical signal back to an electrical signal
- A fiber optic data link consists of three parts – transmitter, optical fiber and receiver below shows the fiber optic connection. The transmitter, optical fiber and receiver perform basic functions of the fiber optic data link.

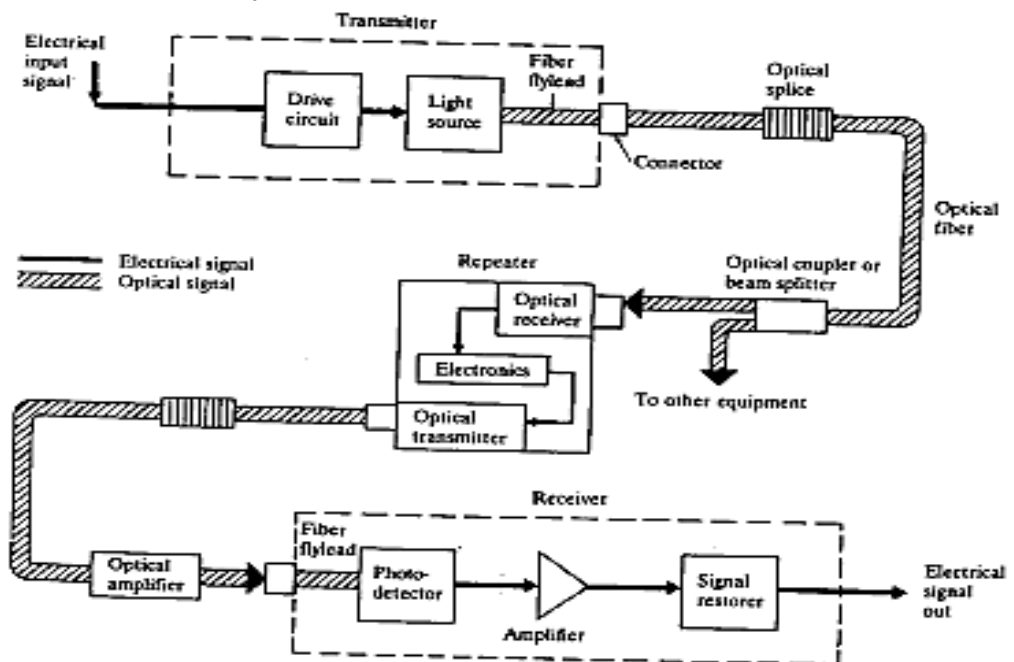

Fig: Major Elements of a Optical Fiber Transmission Link

- The transmitter, consisting of a light source can effectively convert an electrical input into an optical signal and launch the data containing light down the optical fiber.
- A receiver consisting of a photo detector plus amplification and signal-restoring circuit effectively detects the optical signal and transform this optical signal back into its original form.
- Additional components include optical connectors, splices, couplers or beam splitters, repeaters.

Transmitter

- The transmitter is used to launch optical power into the fiber.
- The two types of optical sources are: light-emitting diodes(LEDs) and Laser diodes.
- The electric input signals to the transmitter circuitry convert these electric signals to optical signals by varying the current flow through the light source.
- An optical source is a square-law device, which means that a linear variation in drive current results in a quadratic variation in optical power.

results in a corresponding linear change in the optical output power.

- In the 800-900 nm region the light sources are generally alloys of GaAlAs. At the longer wavelengths (1100 to 1600 nm), an InGaAsP alloy is the principal optical source material.
- After an optical signal has been launched into the fiber, it will become progressively attenuated and distorted with increasing distance because of scattering, absorption and dispersion mechanisms in the waveguide.
- When an optical signal has travelled a certain distance along the fiber, the signal has become attenuated and distorted to such a degree that a repeater is needed in the transmission line to amplify and reshape the signal.
- An optical repeater consists of a receiver and a transmitter placed back to back. The receiver section detects the optical signal and converts it to an electric signal, which is amplified, reshaped and sent to the electric input of the transmitter section.
- The transmitter section converts this electric signal back to an optical signal and sends it on down the optical fiber waveguide.
- Finally, The coupler must efficiently transfer the modulated light beam from the source to the optic fiber.

Information Channel

- The information channel is the path between the transmitter and receiver.
- The cabled optical fiber is one of the most important elements in an optical fiber link. In addition to protecting the glass fibers during installation and service, the cable may contain copper wires for powering repeaters which are needed for periodicity amplifying and reshaping the signal when the link spans long distances.
- The cable generally contains several cylindrical hair-thin glass fibers, each of which is an independent communication channel. Analogous to copper cables, the installation of optical fiber cables can be aerial in ducts, undersea or buried directly in the ground.
- Individual cable lengths will range from several hundred meters to several kilometers for long-distance applications. The shorter lengths tend to be used when the cables are pulled through ducts. Longer cable lengths are used in aerial or direct-burial applications.
- The complete long distance transmission line is formed by splicing or connecting together these cable sections.

Receiver

- The design of the receiver is inherently more complex than that of the transmitter, since it has to both amplify and reshape the degraded signal received by the photo detector.
- The ability of a receiver to achieve a certain performance level depends on the photo detector type, the effects of noise in the system, and the characteristics of the successive amplification stages in the receiver.
- At the receiver the attenuated and distorted modulated optical power emerging from the fiber end will be detected by a photodiode.
- Analogous to the light source, the photo detector is also a square-law device since it converts the received optical power directly into an electric current output (photocurrent).
- Semiconductor pin and avalanche photodiodes (APDs) are the two principal photo detectors

used in a fiber optical link.

- For low power application optical signal is received an avalanche photodiode is normally used, since it has greater sensitivity.
- Silicon photodetectors are used in the 800-900 nm regions. A variety of optical detectors are available at the longer wavelengths. The prime material candidate in the 1100 to 1600 nm region is an InGaAs alloy.

Advantages Of Optical Communication System:

1. Enormous Potential Bandwidth:

The optical carrier frequency in the range of 10^{13} to 10^{16} Hz (10^4 Tera hertz) gives a greater potential transmission bandwidth than metallic cable system.

2. Small Size and Weight:

Optical fiber has a very small diameter (diameter of a human hair). Hence, even such fibers are covered with protective coatings they are far smaller and lighter than copper cables.

3. Electrical Isolation:

Optical fiber which are fabricated from glass or plastic polymer are electrical insulators unlike their metallic counter parts, they do not exhibit earth loop and interface problem. Therefore, Optical fiber transmission is ideally suited for electrical hazardous environment as the fiber creates no arcing (or) spark hazard at abrasion (or) short circuits.

4. Immunity to Interference and Crosstalk:

- ❖ Optical fiber forms a dielectric wave guide and free from electromagnetic interference (EMI), radio frequency interference (RFI) (or) switching transient giving electromagnetic pulses (EMP).
- ❖ Optical fiber transmission requires no shielding from EMI when it is used in electrically noisy environment.
- ❖ Fiber cable also not suitable to lightning strikes if used over head rather underground.

5. Signal Security:

- ❖ The light from optical fiber doesn't radiate significantly and therefore likely provide a high degree of signal security.
- ❖ Transmitted optical signal cannot be trapped by third person. This feature is attractive for military, banking and general data transmission applications.

6. Low Transmission Loss:

- ❖ Optical fiber exhibit low attenuation (or) transmission loss in comparison with the best copper conductors. Fibers have been fabricated with losses as low as 0.2 dB/km.

7. Ruggedness and Flexibility:

- ❖ Fibers are manufactured with high tensile strengths. The fibers may also be bent to quite small radii (or) twisted without damage.
- ❖ Because of the small sized, weight and flexibility optical fibers are generally superior in terms of storage, transportation, handling and installation to corresponding copper cables.

8. System Reliability And Ease Of Maintenance:

- ❖ Low loss property of optical fiber cables reduces the requirements for intermediate repeaters (or) line amplifiers to boost the transmitted signal strength with fewer repeaters reliability is

enhanced in comparison to conventional electrical system.

- ❖ Life time of optical fibers is 20 to 30 years. It reduces maintenance time and cost.

PROPAGATION OF LIGHT.

- Until the early seventeenth century it was generally believed that the light consisted of a stream of minute particles that were emitted by luminous sources. These particles were pictured as travelling in straight lines, and it was assumed that they could penetrate transparent materials but were reflected from opaque ones.
- This theory adequately described certain large scale optical effects such as reflection and refraction, but failed to explain finer-scale such as interference and diffraction.
- Later the work of Maxwell in 1864 theorized that light waves must be electromagnetic in nature. Furthermore observation of polarization effects indicated that light waves are transverse (that is, the wave motion is perpendicular to the direction in which the wave travels.)
- The electromagnetic wave radiated by a small optical source can be represented by a train of spherical wave fronts with the source at the center as shown in figure.

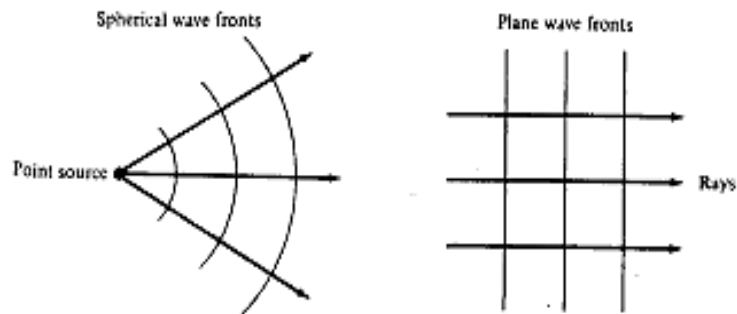

Fig; Representation of Spherical and Plane Wave front

- A wave front is defined as the locus of all points in the wave train which have the same phase.
- The speed of electromagnetic wave (c) in free space is approximately 3×10^8 m/sec.
- The distance travelled during each cycle is called as wavelength (λ)

$$\text{Wavelength} = \frac{\text{Speed of light}}{\text{frequency}} = \frac{c}{f}$$

- In fiber optics, it is more convenient to use the wavelength of light instead of the frequency with light frequencies; wavelength is often stated in microns or nanometers.

$$1 \text{ micron } (\mu) = 1 \text{ Micrometre } (1 \times 10^{-6})$$

$$1 \text{ nano } (n) = 10^{-9} \text{ metre}$$

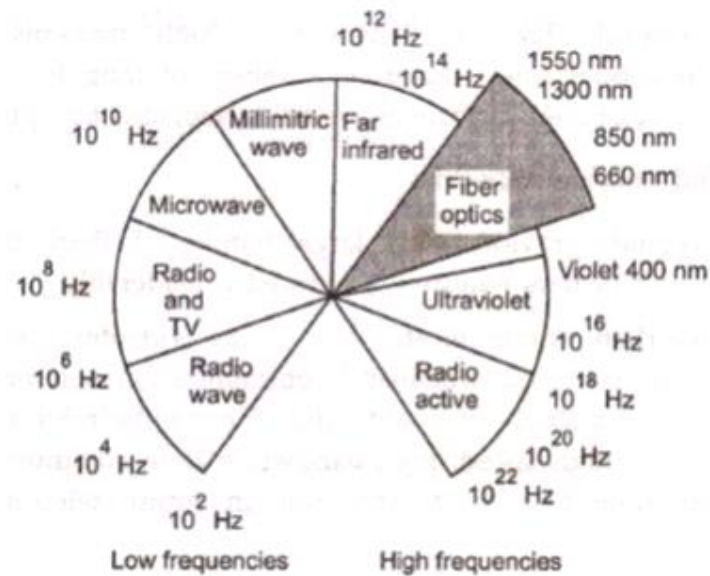

Fig: Electromagnetic Spectrum

- Fiber optics uses visible and infrared light. Infrared light covers a fairly wide range of wavelengths and is generally used for all fiber optic communications. Visible light is normally used for very short range transmission using a plastic fiber.
- The photon energy is found to depend only on the frequency. This frequency in turn must be measured by observing a wave property of light.
- The relationship between the energy E and the frequency ν of a photon is given by,

$$E = h\nu$$

Where, $h = 6.625 \times 10^{-34} \text{ J}$ is Planck's constant.

- When light is incident on an atom, a photon can transfer its energy to an electron within this atom, thereby exciting it to a higher energy level.
- The energy absorbed by the electron must be exactly equal to that required to excite state can drop to a lower state separated from it by an energy $h\nu$ by emitting a photon of exactly this energy.
- Before studying how the light actually propagates through the fiber, laws governing the nature of light must be studied. This is called as **laws of optics (Ray theory)**.
- The speed of light depends upon the material or medium through which it is moving. In free space light travels at its maximum possible speed i.e. $3 \times 10^8 \text{ m/s}$ or $186 \times 10^3 \text{ miles/sec}$.
- When light travels through a material it exhibits certain behavior explained by laws of reflection, refraction.

Reflection

- The law of reflection states that, when a light ray is incident upon a reflective surface at some incident angle θ_1 from imaginary perpendicular normal, the ray will be reflected from the surface at some angle θ_2 from normal which is equal to the angle of incidence.

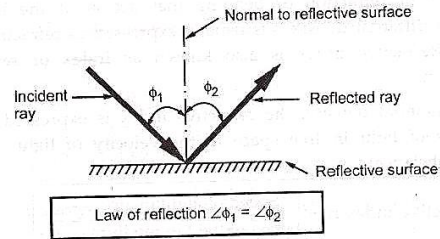

Fig: Reflection

Refraction

- Refraction occurs when light ray passes from one medium to another i.e. the light ray changes its direction at interface. Refraction occurs whenever density of medium changes. E.g. refraction occurs at air and water interface, the straw in a glass of water will appear as it is bent. The refraction can also be observed at air and glass interface.
- When wave passes through less dense medium to denser medium, the wave is refracted (bent) towards the normal. Fig. below shows the refraction phenomena.

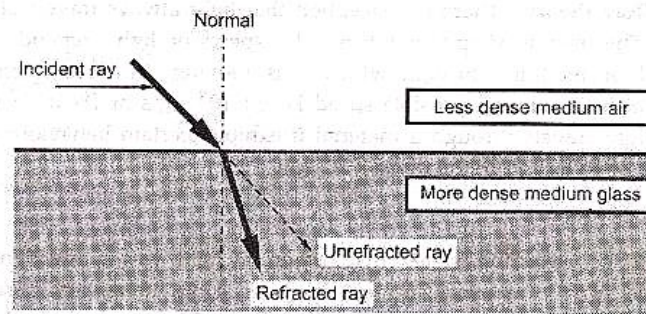

Fig: Refraction

- The refraction (bending) takes place because light travels at different speeds in different mediums. The speed of light in free space is higher than in water or glass.

Refractive Index

- The amount of refraction or bending that occurs at the interface of two materials of different densities is usually expressed as refractive index of two materials. Refractive index is also known as **index of refraction** and is denoted by n .
- Based on material density, the refractive index is expressed as the ratio of the velocity of light in free space to the velocity of light of the dielectric material (substance).

$$\text{Refractive index, } n = \frac{\text{Speed of light in air}}{\text{Speed of light in medium}} = \frac{c}{V}$$

- The refractive index for vacuum and air is 1.0. For water it is 1.3 and for glass refractive index is 1.5.

Snell's Law

- Snell's law states how light ray reacts when it meets the interface of two media having different indexes of refraction.
- Let the two media have refractive indexes n_1 and n_2 where $n_1 > n_2$. Let θ_1 and θ_2 be the angles of incidence and angle of refraction respectively. Then according to Snell's law, a relationship exists

between the refractive index of both materials given by,

$$n_1 \sin \theta_1 = n_2 \sin \theta_2$$

Where, n_1 is the refractive index of the core

n_2 is the refractive index of the cladding

- A refractive index model for Snell's law is shown in figure below:

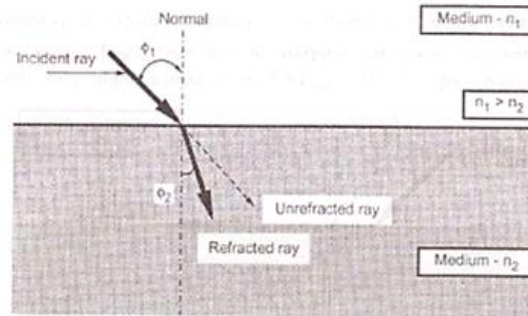

Fig: Refractive Model for Snell's law

- The refracted wave will be towards the normal when $n_1 < n_2$ and will away from it when $n_1 > n_2$. And, the equation below shows that the ratio of refractive index of two mediums is inversely proportional to the refractive and incident angles.

$$\frac{n_1}{n_2} = \frac{\sin \theta_2}{\sin \theta_1}$$

CONCEPT OF OPTICAL FIBER STRUCTURES

- The basic structure of an optical fiber consists of three parts; the core, the cladding and the coating or buffer. The basic structure of an optical fiber is shown on figure below.

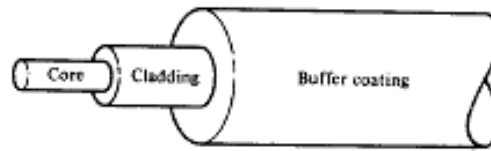

Fig: Structure of a single Fiber

- The core is a cylindrical rod of dielectric material. Dielectric material conducts no electricity. Light propagates mainly along the core of the fiber. The core is generally made of glass. The core is described as having a radius of 'a' and an index of refraction 'n1'.
- The core is surrounded by a layer of material called the cladding. Even though light will propagate along the fiber core without the layer of cladding material, the cladding does perform some necessary functions.
- The cladding layer is made of a dielectric material with an index of refraction 'n2'. The refractive index of the cladding material is less than that of the core material.
- The cladding is generally made of glass or plastic. The cladding performs the following functions:
 - ✓ Reduces loss of light from the core into the surrounding air
 - ✓ Reduces scattering loss at the surface of the core.
 - ✓ Protects the fiber from absorbing surface contaminants
 - ✓ Adds mechanical strength.
- For extra protection, the cladding is enclosed in an additional layer called the coating or buffer. The coating or buffer is a layer of material used to protect an optical fiber from physical damage. The material used for a buffer is a type of plastic.
- The buffer is elastic in nature and prevents abrasions. The buffer also prevents the optical fiber from scattering losses caused by microbends. Microbends occur when an optical fiber is placed on a rough and distorted surface.
- The basic fiber building blocks are used to form large cable. These units are bound on a buffer material which acts as strength element along with insulated copper conductor. The fiber building blocks are surrounded by paper tape, PVC jacket, yarn and outer sheath.

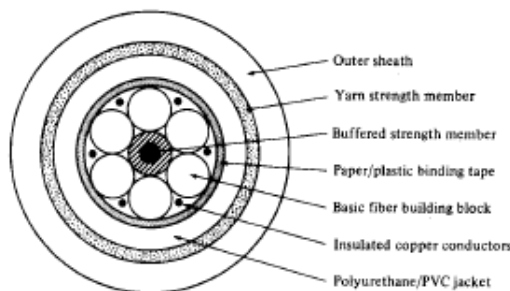

Fig: Six Fiber cable

Fiber Optic Cable Ducts

- Number of cores is bundled in plastic ducts. To ease identification, individual fibers are color coded
Table below shows an example of the color coding used by manufacturers.

Fiber number Color

Fiber Number	Color
1	Blue
2	Orange
3	Green
4	Brown
5	Grey
6	White
7	Red
8	Black
9	Yellow
10	Violet
11	Pink or Light blue
12	Turquoise or Neutral

Optical Fiber types

- Variations in the material composition of the core give rise to the two commonly used fibertypes shown in figure below: In the first case the refractive index of the core is uniform throughout and undergoes an abrupt change (or step) at the cladding boundary. This is called **step-index fiber**.
- The core typically has diameter of 50-80 μm and the cladding has a diameter of 125 μm .
- The refractive index profile of the step-index fiber is defined as,

$$n(r) = \begin{cases} n_1 & \text{where } r < a(\text{core}) \\ n_2 & \text{where } r \geq a(\text{cladding}) \end{cases}$$

- Second case the core refractive index is made to vary as a function of the radial distance from the center of the fiber. This type is a **graded-index fiber**.

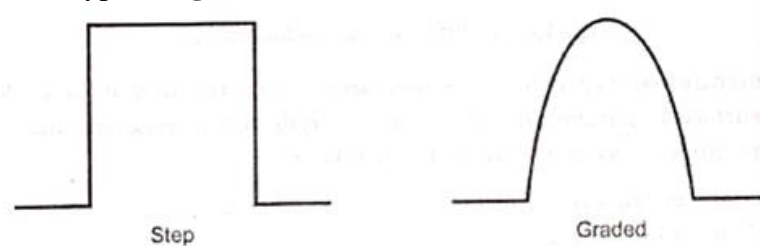

Fig: Index Profile

- The refractive index profile across the core takes the parabolic nature as shown in figure above.
- A graded index fiber has lower coupling efficiency and higher bandwidth than the step index fiber. It is available in 50/125 and 62.5/125 sizes. The 50/125 fiber has been optimized for long haul applications and has a smaller NA and higher bandwidth. 62.5/125 fiber is optimized for LAN applications which is costing 25% more than the 50/125 fiber cable.
- The refractive index variation in the core is given by relationship

$$n(r) = \begin{cases} n_1 \left(1 - 2\Delta \left(\frac{r}{a}\right)^\alpha\right) & \text{when } r < a(\text{core}) \\ n_2 (1 - 2\Delta)^{1/2} \approx n_2 & \text{when } r \geq a(\text{cladding}) \end{cases}$$

Where, r- Radial distance from fiber axis

a- Core radius
 n_1 - Refractive index of core
 n_2 - Refractive index of core
 α - Shape of index profile

- Profile parameter α determines the characteristic refractive index profile of fiber core.
- The range of refractive index as variation of α is shown in Figure below.

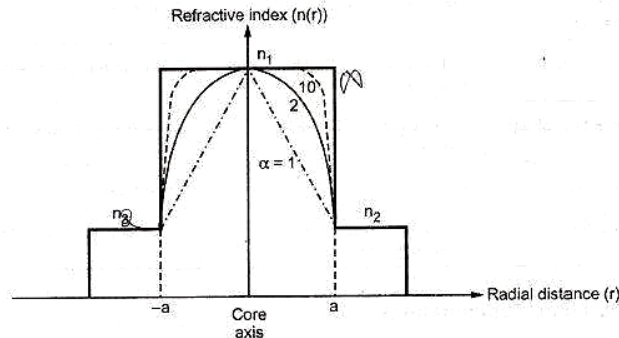

Fig: Possible fiber refractive index profiles for different values of α

- Both Step and graded-index fibers can be further divided into **singlemode** and **multimode** classes. Single Mode fiber sustains only one mode of propagation, whereas multimode fibers contain many hundreds of modes.

Single Mode Fibers

- Single mode fiber allows propagation to light ray by only one path.
- The core size of single mode fibers is small. The core size (diameter) is typically around 8 to 12 micrometers. A fiber core of this size allows only the fundamental or lowest order mode to propagate only one mode, because the core size approaches the operational wavelength. The value of the normalized frequency parameter relates core size with mode propagation.
- In single mode fibers, the frequency is less than or equal to 2.405. When the frequency and wavelength 2.405, single mode fibers propagate the fundamental mode down the fiber core, while high-order mode are lost in the cladding. For low frequency values, most of the power is propagated in the cladding material. Power transmitted by the cladding is easily lost at the fiber ends. The value of frequency should remain near the 2.405 level.
- Single mode fibers have a lower signal loss and a higher information capacity (bandwidth) than multimode fibers. Single mode fibers are capable of transferring higher amounts of data to low fiber dispersion.
- In single mode fibers, the wavelength can increase or decrease the losses caused by fiber bending. They lose power because light radiates into cladding, which is lost at fiber bends. In general, single mode fibers are considered to be low-loss fibers which increase system bandwidth and length.
- Some disadvantages of single mode fiber are smaller core diameter makes coupling light into the core more difficult.

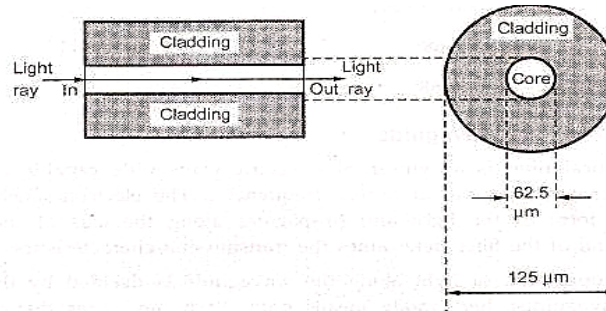

Fig: Single Mode Propagation

Multimode Fibers

- The term multimode simply refers to the fact that numerous modes (light rays) are carried simultaneously through the waveguide. Multimode fiber has a much larger diameter, compared to single mode fiber; this allows large number of modes.
- Another advantage is that multimode fibers permit the use of light emitting diodes (LEDs). Single mode fibers typically must use laser diodes. LEDs are cheaper, less complex and last longer. LEDs are preferred for most applications.
- The disadvantage is that multimode fibers suffers from intermodal dispersion

Optic Fiber Configurations

- Depending on the refractive index profile of fiber and modes of fiber there exist three types of optical fiber configurations. These optic-fiber configurations are -
 - i) Single mode step index fiber.
 - ii) Multimode step index fiber.
 - iii) Multimode graded index fiber

Single mode Step index Fiber

- Single mode step index fiber has a central core that is sufficiently small so that there is essentially only one path for light ray through the cable. The light ray is propagated in the fiber through reflection.
- Typical core sizes are 8 to 12 μ m.
- Single mode fiber is also known as fundamental or monomode fiber.
- Single mode fiber will permit only one mode to propagate and does not suffer from mode delay differences. These are primarily developed for the 1300 nm window but they can be also be used effectively with time division multiplex (TDM) and wavelength division multiplex (WDM) systems operating in 1550 nm wavelength region.
- The core fiber of a single mode fiber is very narrow compared to the wavelength of light being used. Therefore, only a single path exists through the cable core through which light can travel.
- The disadvantage of this type of cable is that because of extremely small size interconnection of cables and interfacing with source is difficult.
- Another disadvantage of single mode fibers is that as the refractive index of glass decreases with optical wavelength, the light velocity will also be wavelength dependent. Thus the light from an optical transmitter will have definite spectral width.

Multimode step Index Fiber

- **Multimode step index fiber** is more widely used type. It is easy to manufacture. Its core diameter is

50 to 1000 μm i.e. large aperture and allows more light to enter the cable. The light rays are propagated down the core in zig-zag manner.

- There are many paths that a light ray may follow during the propagation.
- The light ray is propagated using the principle of total internal reflection. Since the core index of refraction is higher than the cladding index of refraction, the light enters at less than critical angle is guided along the fiber.
- Light rays passing through the fiber are continuously reflected off the glass cladding towards the center of the core at different angles and lengths, limiting overall bandwidth.
- The disadvantage of multimode step index fibers is that the different optical lengths caused by various angles at which light is propagated relative to the core, causes the transmission bandwidth to be fairly small. Because of these limitations, multimode step index fiber is typically only used in applications requiring distances of less than 1 km.

Multimode Graded Index Fiber

The core size of **multimode graded index fiber** cable is varying from 50 to 100 μm range.

- The light ray is propagated through the refraction. The light ray enters the fiber at many different angles.
- As the light propagates across the core toward the center it is intersecting a less dense to more dense medium.
- Therefore the light rays are being constantly being refracted and ray is bending continuously. This cable is mostly used for long distance communication.

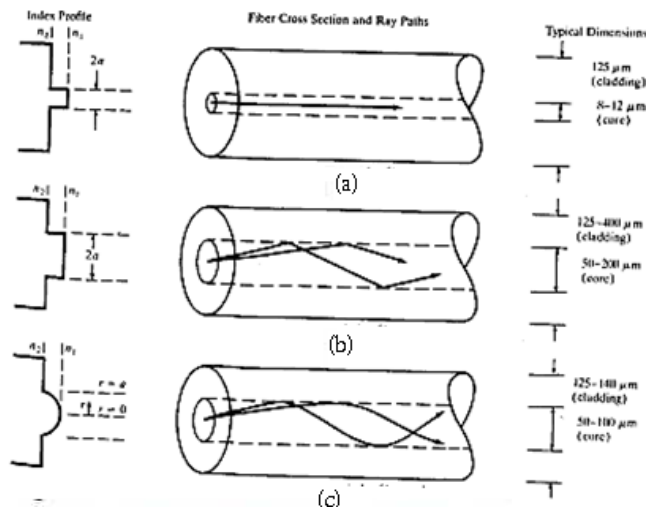

**Fig (a) Single mode step index Fiber (b) Multimode Step-index Fiber
(c) Multimode graded-index Fiber**

- The light rays no longer follow straight lines; they follow a serpentine path being gradually bent back towards the center by the continuously declining refractive index.
- The modes travelling in a straight line are in a higher refractive index so they travel slower than the serpentine modes. This reduces the arrival time disparity because all modes arrive at about the same time.
- Figure below shows the light trajectory in detail. It is seen that light rays running close to the fiber

axis with shorter path length, will have a lower velocity because they pass through a region with a high refractive index.

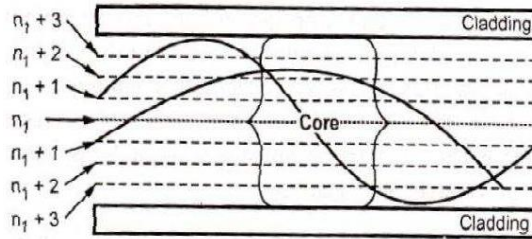

- Rays on core edges offers reduced refractive index, hence travel more faster than axial rays and cause the light components to take same amount of time to travel the length of fiber, thus minimizing dispersion losses.
- Each path at a different angle is termed as ‘**transmission mode**’ and the NA of graded index fiber is defined as the maximum value of acceptance angle at the fiber axis.
- Typical attenuation coefficients of graded index fibers at 850 nm are 2.5 to 3 dB/km, while at 1300 nm they are 1.0 to 1.5 dB/km. The main advantages of graded index fiber are:
 - ✓ Reduced refractive index at the center of core.
 - ✓ Comparatively cheap to produce.

Numerical Aperture

- The **numerical aperture (NA)** of a fiber is a figure of merit which represents its light gathering capability. Larger the numerical aperture, the greater the amount of light accepted by fiber. The acceptance angle also determines how much light is able to be enter the fiber and hence there is relation between the numerical aperture and the cone of acceptance.
- The rays striking the core-cladding interface at angles less than θ_{min} will refract out of the core and be lost in the cladding.

$$\sin \theta_{min} = \frac{n_2}{n_1}$$

- The condition of the above equation can be related to the maximum entrance angle θ_{max} through the relationship

$$n_0 \sin \theta_{max} = n_1 \sin \theta_c = (n_1^2 - n_2^2)^{1/2}$$

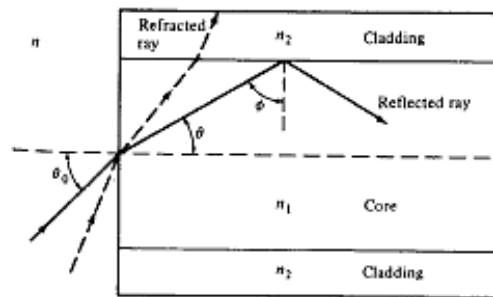

Fig: Meridional Ray optic representation of the propagation mechanism

- Thus, Numerical Aperture, $NA = \sin^{-1} \theta_{max} = \frac{(n_1^2 - n_2^2)^{1/2}}{n_0} = n_1 \sqrt{2\Delta}$

Where, Δ is much less than 1. For air $\Delta = 1$. Thus,

$$NA = (n_1^2 - n_2^2)^{1/2} =$$

Where, n_1 - refractive index of the core; n_2 - refractive index of the cladding.

- By the formula of NA note that the numerical aperture is effectively dependent only on

refractive indices of core and cladding material. NA is not a function of fiber dimension.

- The numerical aperture is a dimensionless quantity which is less than unity, with values normally ranging from 0.14 to 0.50.

Also, the acceptance angle can be calculated by using the formula,

$$\text{Acceptance angle } \theta_0 = \sin^{-1}(\text{Numerical Aperture})$$

- The Cone of acceptance is the angle within which the light is accepted into the core and is able to travel along the fiber. The launching of light wave becomes easier for large acceptance angle.

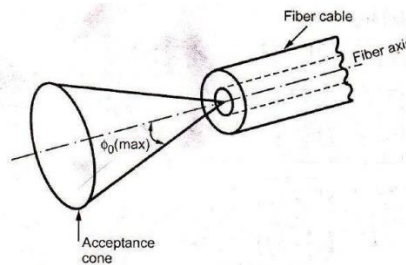

Fig: Acceptance Cone of Optic Fiber

- The angle is measured from the axis of the positive cone so the total angle of convergence is actually twice the stated value

Introduction

- The signal attenuation of fiber determines the maximum distance between transmitter and receiver. The attenuation also determines the number of repeaters required, maintaining repeater is a costly affair.

Attenuation

- Attenuation of a light as it propagates along a fiber is an important consideration in the design of an optical communication system in determining the maximum transmission distance between a transmitter and a receiver.
- Attenuation in an optical fiber is caused by absorption, scattering and bending losses.
- Absorption is related to the fiber material, whereas scattering is associated both with the fiber material and with structural imperfections in the optical waveguide.
- Scattering due to structural imperfection within the fiber. Nearly 90 % of total attenuation is caused by Rayleigh scattering only.
- The Rayleigh scattering is wavelength dependent and reduces rapidly as the wavelength of the incident radiation increases.
- Microbending of optical fiber also contributes to the attenuation of signal.

Attenuation Units

- Signal attenuation (or fiber loss) is defined as the ratio of the optical output power P_{out} from a fiber of length L to the optical input power P_{in} . This power ratio is a function of wavelength. The symbol α is commonly used to express attenuation in decibels per kilometer (dB/Km).

$$\alpha = \frac{10}{L} \log \left(\frac{P_{in}}{P_{out}} \right)$$

Absorption

- Absorption is caused by three different mechanisms:
 1. Absorption by atomic defects in the glass composition
 2. Extrinsic absorption by impurity atoms in the glass material
 3. Intrinsic absorption by the basic constituent atoms of the fiber material.
- Atomic defects are imperfections of the atomic structure of the fiber material such as missing molecules, high-density clusters of atom groups or oxygen defects in the glass structure.
- Usually absorption losses arising from these defects are negligible compared to intrinsic and impurity absorption effects.
- The absorption effect is most significant when fiber is exposed to ionizing radiation in nuclear reactor, medical therapies, space missions etc. The radiation damages the internal structure of fiber. The damages are proportional to the intensity of ionizing particles. This results in increasing attenuation due to atomic defects and absorbing optical energy.
- The total dose a material receives is expressed in rad (Si), this is the unit for measuring radiation absorbed in bulk silicon.

$$1 \text{ rad (Si)} = 0.01 \text{ J.kg}$$

- The higher the radiation intensity more the attenuation as shown in Fig shown below:

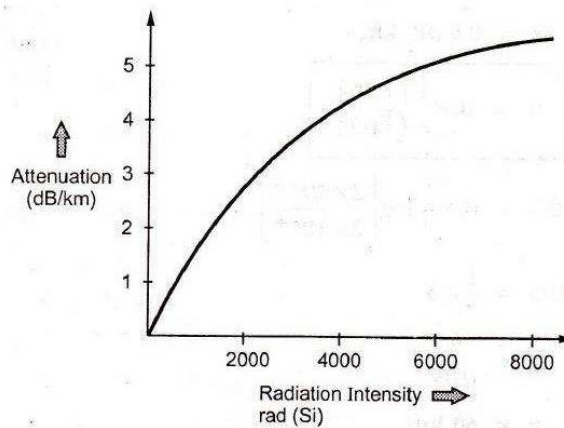

Fig: Ionizing Radiation intensity Vs Fiber Attenuation

Intrinsic Absorption

- Intrinsic absorption is associated with the basic fiber material and is the principal physical factor that defines the transparency window of a material over a specified spectral region.
- It occurs when the material is in a perfect state with no density variations, impurities, material in homogeneities, etc.,
- Intrinsic absorption thus sets the fundamental lower limit on absorption for any particular material.

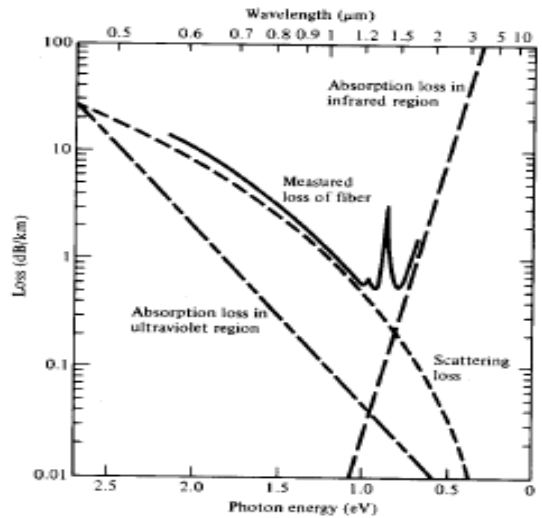

Fig: Optical Fiber Attenuation Characteristics

- Intrinsic absorption results from electronic absorption bands in the ultraviolet region and from atomic vibration bands in the near infrared region. The electronic absorption bands are associated with the band gaps of the amorphous glass materials.
- Absorption occurs when a photon interacts with an electron in the valence band and excites it to a higher energy level.
- The magnitude and characteristic exponential decay of the ultraviolet absorption is shown in figure:
- The ultraviolet loss is small compared to scattering loss in the near infrared region.

Extrinsic Absorption

- Extrinsic absorption occurs due to electronic transitions between the energy level and because of charge transitions from one ion to another. A major source of attenuation is from transition of metal impurity ions such as iron, chromium, cobalt and copper. These losses can be upto 1 to 10 dB/km. The effect of metallic impurities can be reduced by glass refining techniques.
- Another major extrinsic loss is caused by absorption due to **OH (Hydroxyl)** ions impurities dissolved in glass. Vibrations occur at wavelengths between 2.7 and 4.2 μm.
- The absorption peaks occurs at 1400, 950 and 750 nm. These are first, second and third overtones respectively.
- Figure below shows absorption spectrum for OH group in silica. Between these absorption peaks there are regions of low attenuation.

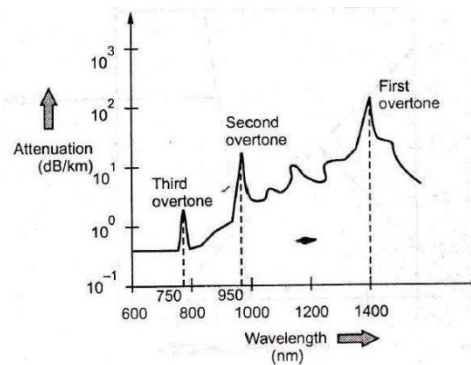
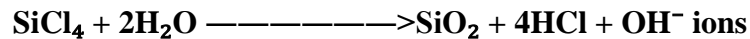

Fig: Absorption Spectra for OH group

- These absorption peaks define three regions or windows of preferred operation. The first window is centered at 850 nm. The second window is centered at 1300 nm. The third window is centered at 1550 nm. Fiber optic systems operate at wavelengths defined by one of these windows.
- The amount of water(OH⁻) impurities present in a fiber should be less than a few parts per billion. Fiber attenuation caused by extrinsic absorption is affected by the level of impurities(OH⁻) present in the fiber. If the amount of impurities in a fiber is reduced, then fiber attenuation is reduced.
- Hydrolysis method is one of the fabrication processes of optical fiber. The starting materials used in this method are SiCl₄, GeCl₄, & PoCl₃. During hydrolysis process i.e., when these materials used in hydrolysis process, gives OH ions.



Flame hydrolysis

Scattering Losses

A beam propagating at the critical angle will change direction after it meets an obstacle. Therefore, the light will be scattered. The scattering effects prevent the attainment of TIR at the core-cladding boundary resulting in power loss. This loss is known as SCATTERING LOSS.

- ✓ Linear scattering losses
- ✓ Non-linear scattering losses
- Scattering losses arise from microscopic variations in the material density, from compositional fluctuations, and from structural inhomogeneities or defects, occurring during fiber manufacture.
- Scattering losses exist in optical fibers because of microscopic variations in the material density and composition. As glass is composed by a randomly connected network of molecules and several oxides (e.g. SiO₂, GeO₂ and P₂O₅), these are the major cause of compositional structure fluctuation.
- ✓ **Linear scattering losses:**

Linear scattering mechanism causes transfer of optical power from one mode to different mode.

This process tends to result in attenuation of the transmitted light as the transfer may be to a leaky mode (or) radiation mode which does not continue to propagate within the fiber. There are two types of linear scattering losses.

1. Rayleigh Scattering
2. Mie Scattering

Rayleigh Scattering

- Rayleigh scattering in glass is the same phenomenon that scatters light from the sun in the atmosphere, thereby giving rise to a blue sky.
- Rayleigh scattering of light is due to small localized changes in the refractive index of the core and cladding material. There are **two causes** during the manufacturing of fiber.
- The first is due to slight fluctuation in mixing of ingredients. The random changes because of this are impossible to eliminate completely.
- The other cause is slight change in density as the silica cools and solidifies. When light ray strikes such zones it gets scattered in all directions. The amount of scatter depends on the size of the discontinuity compared with the wavelength of the light so the shortest wavelength (highest frequency) suffers most scattering.
- The expressions for scattering induced attenuation are fairly complex owing to the random

molecular nature and the various oxide constituents of glass.

- For single component glass the scattering loss at a wavelength λ resulting from density fluctuations can be approximated by,

$$\alpha_{scat} = \frac{8\pi^3}{3\lambda^4} (n^2 - 1)^2 k_B T_f \beta_T$$

Where, n is the refractive index,

k_B is Boltzmann's constant,

β_T is the isothermal compressibility of the material and the fictive temperature

T_f is the temperature at which the density fluctuations are frozen into the glass as it solidifies.

$$\alpha_{scat} = \frac{8\pi^3}{3\lambda^4} n^8 p^2 k_B T_f \beta_T$$

Where, p is the photo-elastic coefficient

- For Multicomponent glasses the scattering is given by,

$$\alpha = \frac{8\pi^3}{3\lambda^4} (\delta n^2)^2 \delta V$$

Where, (δn^2) – mean square of refractive index over a volume δV

- Figure below shows graphically the relationship between wavelength and Rayleigh scattering loss.

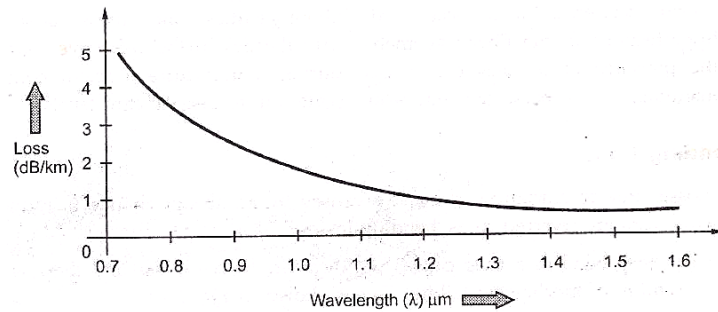

Fig: Scattering Loss

Mie Scattering

- Linear scattering also occurs at inhomogenities and these arise from imperfections in the fiber's geometry, irregularities in the refractive index and the presence of bubbles etc. caused during manufacture. Careful control of manufacturing process can reduce mie scattering to insignificant levels.

Bending Loss

- Radiative losses occur whenever an optical fiber undergoes a bend of finite radius of curvature.
- Fibers can subject to two types of bends: **(a)** microscopic bends having radii that are large compared to the fiber diameter for example, such as occur when a fiber cable turns a corner and **(b)** random microscopic bends of the fiber axis that can arise when the fibers are incorporated into cables.
- The sharp bend of a fiber causes significant radiative losses and there is also possibility of mechanical failure. This is shown in Figure below:

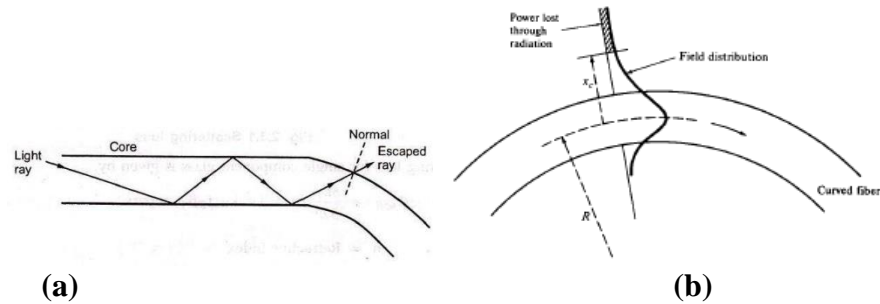

Figure: Bending Loss

- As the core bends the normal will follow it and the ray will now find itself on the wrong side of critical angle and will escape. The sharp bends are therefore avoided.
- The radiation loss from a bent fiber depends on –
 - ✓ Field strength of certain critical distance x_c from fiber axis where power is lost through radiation.
 - ✓ The radius of curvature R .
- The higher order modes are less tightly bound to the fiber core, the higher order modes radiate out of fiber firstly.
- For multimode fiber, the effective number of modes that can be guided by curved fiber is given expression :

$$N_{eff} = N_{\infty} \left\{ 1 - \frac{\alpha + 2}{2\alpha\Delta} \left[\frac{2a}{R} + \left(\frac{3}{2n_2kR} \right)^{2/3} \right] \right\}$$

Where, α – defines the gradex-index profiles

Δ - Core-cladding index difference

n_2 – Refractive index of cladding

$k = \frac{2\pi}{\lambda}$ – Wave propagation constant

$N_{\infty} = \frac{\alpha}{\alpha+2} (n_1ka)^2 \Delta$ - The total number of modes in straight fiber

Micro bend Loss

- Microbends are due to small-scale fluctuations in the radius of curvature of the fiber axis, as shown in figure.
- They are caused either by non-uniformities in the manufacturing of the fiber or by non-uniform lateral pressures created during the cable of the fiber.
- An increase in attenuation results from microbending because the fiber curvature causes repetitive coupling of energy between the guided mode and the leaky or non-guided modes in the fiber.
- One method of minimizing micro bending losses is by extruding a compressible jacket over the fiber. When the external forces will tend to stay relatively straight, as shown in figure below.

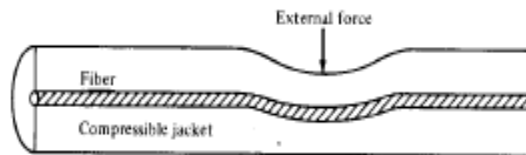

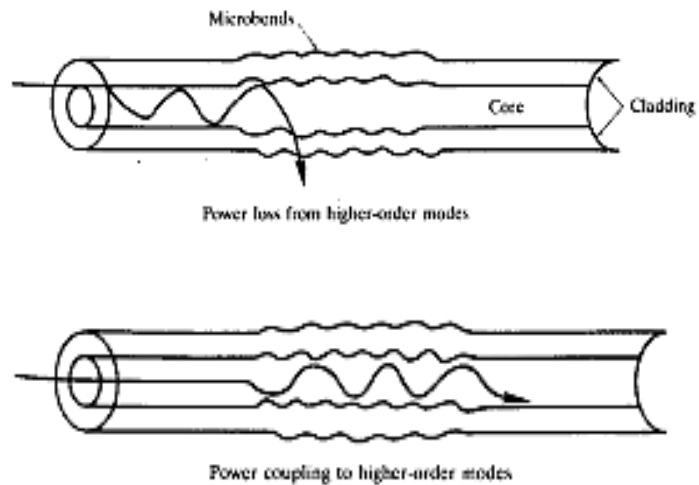

Figure: Micro bending Losses

- For multimode graded-index fiber having a core radius a , outer radius b (excluding the jacket), and index difference Δ , the microbending loss α_M of a jacket is reduced from that of an unjacketed fiber by a factor

$$F(\alpha_M) = \left[1 + \pi \Delta^2 \left(\frac{b}{a} \right)^4 \frac{E_f}{C} \right]^{-2}$$

Here, E_f and E_j are the Young's moduli of the fiber and jacket respectively. The Young's modulus of common jacket materials ranges from 20 to 500 MP and the Young's modulus of fused silica glass is about 65 GPa.

Macro Bending Loss

- The change in spectral attenuation caused by macro bending is different to micro bending. Usually there are no peaks and troughs because in a macro bending no light is coupled back into the core from the cladding as can happen in the case of microbends.
- The macrobending losses are caused by large scale bending of fiber. The losses are eliminated when the bends are straightened. The losses can be minimized by not exceeding the long term bend radii. Figure below illustrates macrobending.

Core-Cladding Loss

- Since the core and cladding have different indices of refraction hence they have different attenuation coefficients α_1 and α_2 respectively. For step index fiber, the loss for a mode order (v, m) is given by,

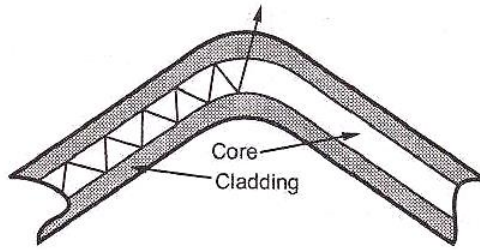

Figure: Macrobending Loss

$$\alpha_{vm} = \alpha_1 \frac{P_{core}}{P} + \alpha_2 \frac{P_{clad}}{P}$$

Where $\frac{P_{core}}{P}$ and $\frac{P_{clad}}{P}$ are the fractional powers

- For low-order modes, the expression reduced to

$$\alpha_{vm} = \alpha_1 + (\alpha_2 - \alpha_1) \frac{P_{clad}}{P}$$

DISPERSION

An optical signal becomes increasingly distorted as it travels along a fiber. This distortion is due to the effects of **intramodal** dispersion and **intermodal** delay effects. These distortion effects can be explained by examining the behavior of the group velocities of the guided modes, where the group velocity is the speed at which energy in a particular mode travels along the fiber.

Intramodal Dispersion

- Intramodal Dispersion is pulse spreading that occurs within a single mode. It is a result of the group velocity being a function of the wavelength λ .
- It depends on the wavelength, its effect on signal distortion increases with the spectral width of the optical source. This spectral width is the band of wavelengths over which the source emits light.
- For LEDs the rms spectral width is approximately 5 % of a central wavelength. Laser diode optical sources have much narrower spectral widths, typical values being 1 to 2 nm.
- The two main causes of intramodal dispersion are:

1. Material Dispersion:

Material Dispersion, which arises from the variation of the refractive index of the core material as a function of wavelength. It is also referred to as chromatic dispersion or spectral dispersion. This causes a wavelength dependence of the group velocity of any given mode; that is pulse spreading occurs even when different wavelengths follow the same path.

2. Wavelength Dispersion:

- ✓ Wavelength dispersion, occurs because a single-mode fiber only confines about 80 % of the optical power to the core.
- ✓ Dispersion thus arises, since the 20 % of the light propagating in the cladding travels faster than the light confined to the core.
- ✓ The amount of waveguide dispersion depends on the fiber design, since the modal propagation constant β is a function of a/λ , (where λ is the wavelength and a is the core radius.)
- Dispersion and attenuation of pulse travelling along the fiber is shown in figure below.

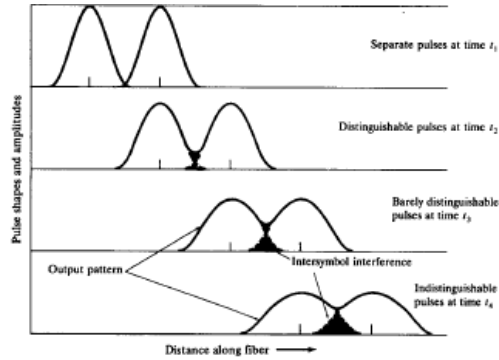

Figure: Broadening and spreading of two adjacent pulses as they travel along fiber

- Figure above shows, after travelling some distance, pulse starts broadening and overlap with the neighboring pulses. At certain distance the pulses are not even distinguishable and error will occur at receiver. Therefore the information capacity is specified by **bandwidth distance product** (MHz * km). For step index bandwidth distance product is 20 MHz*km and for graded index it is 2.5 MHz*km.
- The information carrying capacity can be determined by examining the deformation of short light pulses propagating along the fiber.

Group Delay

- Consider a fiber cable carrying optical signal equally with various modes and each mode contains all the spectral components in the wavelength band.
- All the spectral components travel independently and they observe different **time delay** and **group delay** in the direction of propagation. The group delay per unit length in the direction of propagation is given by,

$$\frac{\tau_g}{L} = \frac{1}{V_g} = \frac{1}{c} \frac{d\beta}{dk} = -\frac{\lambda^2}{2\pi c} \frac{d\beta}{d\lambda}$$

Here, L is the distance travelled by the pulse, β – propagation constant along the fiber axis, $k = 1/2\pi\lambda$

- The velocity at which the energy in a pulse travels along the fiber is known as **group velocity**. Group velocity is given by,

$$V_g = c \cdot \left(\frac{d\beta}{dk} \right)^{-1}$$

- The group delay depends on the wavelength, each spectral component of any particular mode takes a different amount of time to travel a certain distance. As a result of this difference in time delays, the optical signal pulse spreads out with time as it is transmitted over the fiber. Thus it also depends on pulse spreading.

Thus, the dispersion is defined as the pulse spread as a function of wavelength. It is measured in picoseconds per kilometer per nanometer. It is expressed as,

$$D = \frac{1}{L} \frac{d\tau_g}{d\lambda}$$

WAVEGUIDE DISPERSION AND MATERIAL DISPERSION

Material Dispersion

- Material dispersion is also called as chromatic dispersion. Material dispersion exists due to change in index of refraction for different wavelengths. The group velocity V_g of a mode is a function of the index of refraction, the various spectral components of a given mode will travel at different speeds, depending on the wavelength.
- Material dispersion is an intramodal dispersion effect, and is of particular importance for single-mode waveguides and for LED systems.
- By considering a plane wave propagating in an infinity extended medium that has a refractive index $n(\lambda)$ equal to that of the fiber core.
- The propagation constant is thus given by,

$$\beta = \frac{2\pi n(\lambda)}{\lambda}$$

The group delay τ_{Mat} can be written by substituting the value of β for $k = 1/2\pi\lambda$ as,

$$\tau_{Mat} = \frac{L}{c} \left(n - \lambda \frac{dn}{d\lambda} \right)$$

- The material dispersion for unit length ($L = 1$) is given by,

$$D_{Mat} = \frac{-\lambda}{c} \times \frac{d^2n}{d\lambda^2}$$

Where, C - is the velocity of light, λ – center wavelength, $\frac{d^2n}{d\lambda^2}$ – first order derivative of index of refraction w.r.to wavelength. Negative sign shows that the upper sideband signal (lowest wavelength) arrives before the lower sideband (highest wavelength).

- Figure below shows index of refraction as a function of optical wavelength

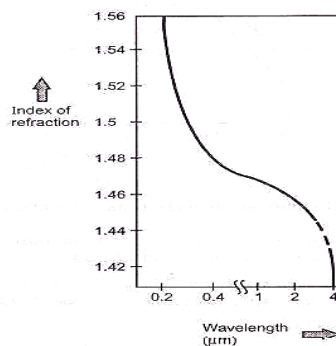

Fig: Index of refraction as a function of wavelength

- Figure below shows the variation of material dispersion as a function of wavelength

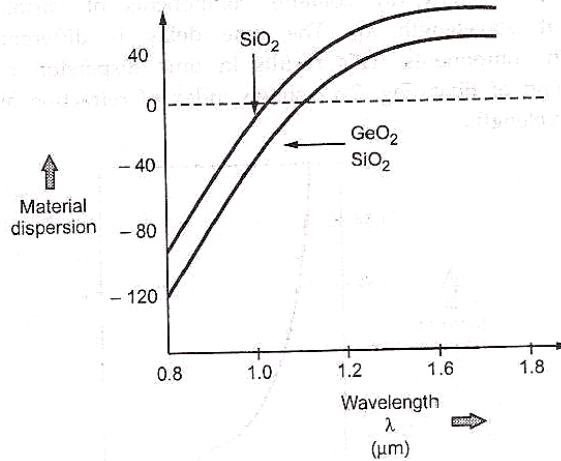

Fig: Material Dispersion as a function of wavelength

- From the figure we understand that the amount of material dispersion depends upon the chemical composition of glass.

Waveguide Dispersion

- Waveguide dispersion is caused by the difference in the index of refraction between the core and cladding, resulting in a 'drag' effect between the core and cladding portions of the power.
- Waveguide dispersion is significant only in fibers carrying fewer than 5-10 modes. Since multimode optical fibers carry hundreds of modes, they will not have observable waveguide dispersion.
- The group delay (τ_{wg}) arising due to waveguide dispersion.

$$\tau_{wg} = \frac{L}{c} \frac{d\beta}{dk} = \frac{L}{c} \left[n_2 + n_2 \Delta \frac{d(kb)}{dk} \right]$$

Where, b – normalized propagation constant $k = 1/2\pi\lambda$ and

Normalized frequency, $V = ka(n_1^2 - n_2^2)^{1/2} = kan_2\sqrt{2\Delta}$

For small values of Δ , V instead of k in group delay yields,

$$\tau_{wg} = \frac{L}{c} \frac{d\beta}{dk} = \frac{L}{c} \left[n_2 + n_2 \Delta \frac{d(Vb)}{dk} \right]$$

The first term is constant and the second term is group delay arising from waveguide dispersion

Signal Distortion in single-mode fiber

- The final factor giving rise to signal degradation is intermodal distortion, which is a result of different values of the group delay for each individual mode at a single frequency.
- The variation in the group velocities of the different modes results in a group delay spread or intermodal distortion. This distortion mechanism is eliminated by single-mode operation, but is important in multimode fibers.
- The pulse broadening arising from intermodal distortion is the difference between the travel time T_{max} of the longest ray congruence paths (the highest-order mode) and the travel time T_{min} of the shortest ray congruence paths (the fundamental mode). This is simply obtained from ray tracing and is given by,

$$\sigma_{mod} = T_{max} - T_{min} = \frac{n_1 \Delta L}{c}$$

Mode Coupling

- After certain initial length, the pulse distortion increases less rapidly because of mode coupling. The energy from one mode is coupled to other modes because of:
 - Structural imperfections.
 - Fiber diameter variations.
 - Refractive index variations.
 - Microbends in cable.
- Due to the mode coupling, average propagation delay becomes less and intermodal distortion reduces.
- Suppose certain initial coupling length = L_c , mode coupling length, over $L_c = Z$. Additional loss associated with mode coupling = h (dB/km). Therefore the excess attenuation resulting from mode coupling = hZ . The improvement in pulse spreading by mode coupling is given as :

$$hZ \left(\frac{\sigma_c}{\sigma_o} \right)^2 = C$$

where, C is a constant, σ_o is the pulse width increase in the absence of mode coupling, σ_c is the pulse broadening in the presence of strong mode coupling, and hZ is the excess attenuation resulting from mode coupling.

For long fiber lengths the effect of mode coupling on pulse distortion is significant. For a graded index fiber, the effect of distance on pulse broadening for various coupling losses is shown in Figure below.

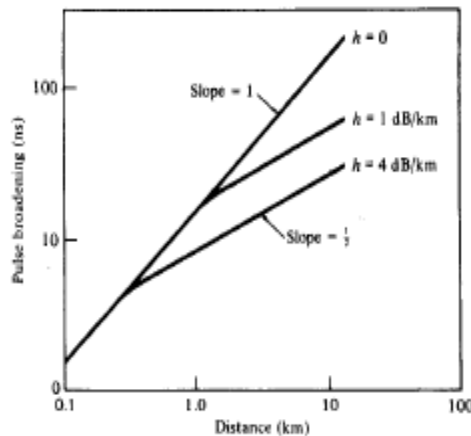
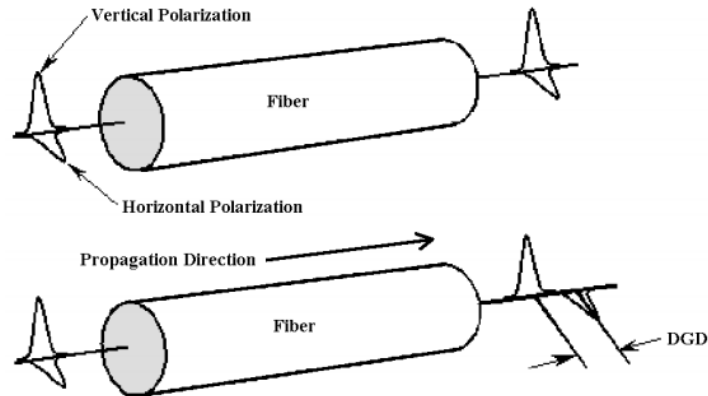

Fig: Mode coupling effects on pulse distortion in long fibers for various coupling losses

Polarization Mode Dispersion (PMD)

- Polarization Mode Dispersion (PMD) is a broadening of the input pulse due to a phase delay between input polarization states. Single-mode optical fiber and components support one fundamental mode, which consists of two orthogonal polarization modes.
- Ideally, the core of an optical fiber is perfectly circular, and therefore has the same index of refraction for both polarization states. However, mechanical and thermal stresses introduced during manufacturing result in asymmetries in the fiber core geometry. This asymmetry introduces small index of refraction differences for the two polarization states, a property called birefringence.
- External mechanical stresses and environmental conditions exacerbate the problem. Birefringence creates differing optical axes that generally correspond to the fast and slow axes. (These axes can also be thought of as corresponding to the Linear Polarization (LP) modes or Principal States of Polarization (PSP).) Birefringence causes one polarization mode to travel faster than the other, resulting in a difference in the propagation time called the differential group delay (DGD).

- DGD is the unit that is used to describe PMD. DGD is typically measured in picoseconds.
- When mode coupling is present, both the PSP and the DGD are also dependent on optical frequency. Mode coupling refers to an exchange of power among propagating polarization modes. This is usually seen in long lengths of single-mode fiber, and is sometimes observed even in short optical components.
- PMD effects resemble those of chromatic dispersion, but with some key differences: Chromatic dispersion is a rather stable, linear effect, making compensation relatively easy, but PMD is a linear effect that is time-varying in fiber links, making compensation difficult. PMD is very stable in components.
- Unlike chromatic dispersion, the effects of PMD are dependent on the launched polarization state. In high-bit-rate systems, PMD may introduce errors as pulses spread into one another.



Design Optimization in Single-mode fibers

- Features of single mode fibers are :
 - Longer life.
 - Low attenuation.
 - Signal transfer quality is good.
 - Modal noise is absent.
 - Largest BW-distance product.
- Basic design – optimization includes the following :
 - Cut-off wavelength.
 - Dispersion.
 - Mode field diameter.
 - Bending loss.
- Single-mode fibers waveguide dispersion is of importance and can be of the same order of magnitude as material dispersion.
- The pulse spread occurring over a distribution of wavelengths is obtained from the derivative of the group delay with respect to wavelength,

$$\begin{aligned} \sigma_{wg} &= \sigma_{\lambda} \frac{d\tau_{wg}}{d\lambda} = \sigma_{\lambda} L Dwg(\lambda) \\ &= -\frac{V}{\lambda} \sigma_{\lambda} \frac{d\tau_{wg}}{dV} = -\frac{n_2 L \Delta \sigma_{\lambda}}{c \lambda} V \frac{d^2(Vb)}{dV^2} \end{aligned}$$

- Where, $Dwg(\lambda)$ – Waveguide dispersion. $V \frac{d^2(Vb)}{dV^2}$ is plotted as a function of V as shown in figure below: This factor reaches a maximum at V=1.2 but runs between 0.2 and 0.1 for a practical single-mode operating range of V = 2.0 to 2.4. thus for values of $\Delta = 0.01$ and $n_2 = 1.5$,

$$\frac{\sigma_{wg}}{L} = -\frac{0.003\sigma_{\lambda}}{c\lambda}$$

The figure above shows that fused –silica –core single mode fiber having $V=2.4$

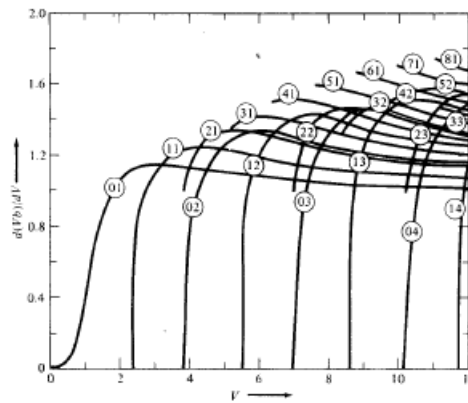

Fig: Group Delay of waveguide dispersion as function of V number of step-index fiber Refractive Index Profile

- Dispersion of single mode silica fiber is lowest at 1300 nm while its attenuation is minimum at 1550 nm. For archiving maximum transmission distance the dispersion null should be at the wavelength of minimum attenuation.
- The waveguide dispersion is easier to control than the material dispersion. Therefore a variety of core-cladding refractive index configuration fibers. Such as 1300 nm – optimized fibers, dispersion shifted fibers, dispersion – flattened fibers and large effective core area fibers.

1300 nm – Optimized Fibers

- These are most popularly used fibers. The two configurations of 1300 nm – optimized single mode fibers are :
 - Matched cladding fibers.
 - Dressed cladding fibers.
- Matched cladding fibers have uniform refractive index throughout its cladding. Typical diameter is 9.0 μm and $\Delta = 0.35\%$.
- Dressed cladding fibers have the innermost cladding portion has low refractive index than outercladding region. Typical diameter is 8.4 μm and $\Delta_1 = 0.25\%$, $\Delta_2 = 0.12\%$.

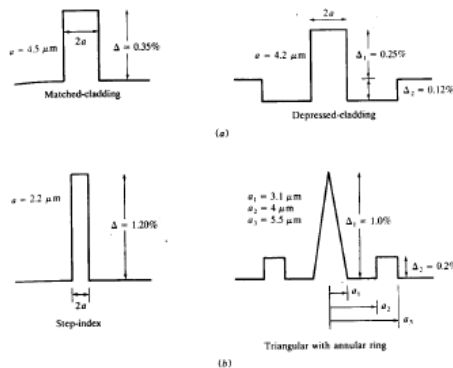

Fig: (a) 1300 nm – Optimized (b) dispersion-shifted

- The addition of wavelength and material dispersion can shift the zero dispersion point of longer

wavelength. Two configurations of dispersion shifted fibers are :

- ✓ Step index dispersion shifted fiber.
- ✓ Triangular dispersion shifted fiber.

Dispersion Flattened

- Dispersion flattened fibers are more complex to design. It offers much broader span of wavelengths to suit desirable characteristics. Two configurations are :

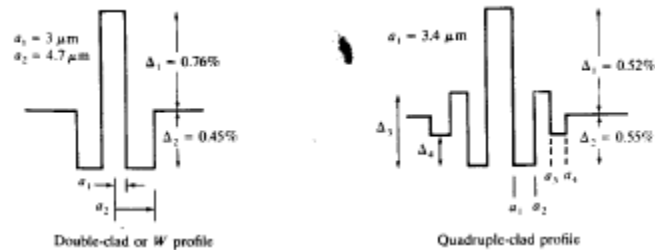

Fig; Dispersion Flattened in single mode fibers

- Figure below shows total resultant dispersion.

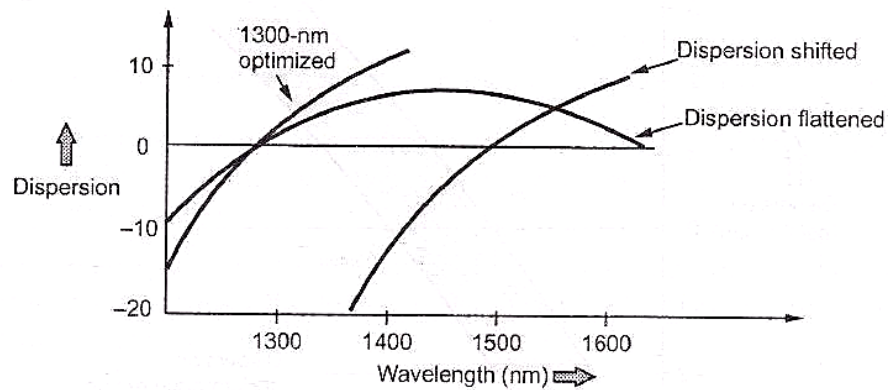

Fig: Total Resultant Dispersion

Dispersion Calculations

- The total dispersion consists of material and waveguide dispersions. The resultant intermodal dispersion is given as,

$$D(\lambda) = \frac{d\tau}{d\lambda}$$

Where, τ is group delay per unit length of fiber

- The broadening σ of an optical pulse is given as,

$$\sigma = D(\lambda)L\sigma\lambda$$

Where, $\sigma\lambda$ – half power spectral width of the source

- As the dispersion varies with wavelength and fiber type. Different formulae are used to calculate dispersions for variety of fiber at different wavelength.
- For a non –dispersion shifted fiber between 1270 nm to 1340 nm wavelength, the expression for the dispersion is given as,

$$D(\lambda) = \frac{\lambda}{4} S_o \left[1 - \frac{\lambda o^4}{\lambda} \right]$$

Where, λ_0 – zero dispersion wavelength, So is the value at dispersion at slope at λ_0

- Figure below shows dispersion performance curve for non-dispersion shifted fibers in 1270 –1340 nm region.

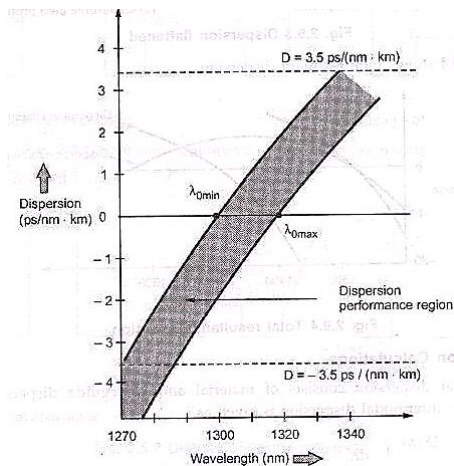

- Maximum dispersion specified as 3.5 ps/(nm . km) marked as dotted line.

Cut-off Frequency of an Optical Fiber

- The cut-off frequency of an optical fiber is determined not only by the fiber itself (modal dispersion in case of multimode fibers and waveguide dispersion in case of single mode fibers) but also by the amount of material dispersion caused by the spectral width of transmitter.

Bending Loss Limitations

- The macro bending and micro bending losses are significant in single mode fibers at 1550 nm region, the lower cut-off wavelengths affects more. Figure below shows macro bending losses.

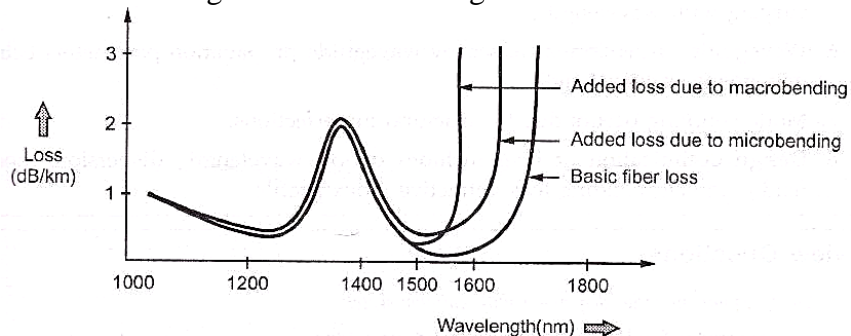

Fig: Fiber attenuation due to micro bending and Macro bending Loss

UNIT-V OPTICAL NETWORKS

SONET/SDH

The ANSI standard is called the Synchronous Optical Network (SONET). The ITU-T standard is called the Synchronous Digital Hierarchy (SDH). SONET was developed by ANSI; SDH was developed by ITU-T. SONET/SDH is a synchronous network using synchronous TDM multiplexing. All clocks in the system are locked to a master clock.

ARCHITECTURE

Architecture of a SONET system contains: signals, devices, and connections.

Signals: SONET defines a hierarchy of electrical signaling levels called synchronous transport signals (STSs). Each STS level (STS-1 to STS-192) supports a certain data rate, specified in megabits per second. The corresponding optical signals are called optical carriers (OCs). SDH specifies a similar system called a synchronous transport module (STM).

SONET Devices: SONET transmission relies on three basic devices: STS multiplexers/demultiplexers, regenerators, add/drop multiplexers and terminals.

STS Multiplexer/Demultiplexer: It marks the beginning points and endpoints of a SONET link. They provide the interface between an electrical tributary network and the optical network. An STS multiplexer multiplexes signals from multiple electrical sources and creates the corresponding OC signal. An STS demultiplexer demultiplexes an optical OC signal into corresponding electric signals.

Regenerator: Regenerators extend the length of the links. A regenerator is a repeater that takes a received optical signal (OC-n), demodulates it into the corresponding electric signal (STS-n), regenerates the electric signal, and finally modulates the electric signal into its correspondent OC-n signal. A SONET regenerator replaces some of the existing overhead information (header information) with new information.

Add/drop Multiplexer: It allows insertion and extraction of signals. An **add/drop multiplexer (ADM)** can add STSs coming from different sources into a given path or can remove a desired signal from a path and redirect it without demultiplexing the entire signal. Instead of relying on timing and bit positions, add/drop multiplexers use header information such as addresses and pointers (described later in this section) to identify individual streams.

In the simple configuration shown by Figure, a number of incoming electronic signals are fed into an STS multiplexer, where they are combined into a single optical signal. The optical signal is transmitted

to a regenerator, where it is recreated without the noise it has picked up in transit. The regenerated signals from a number of sources are then fed into an add/drop multiplexer. The add/drop multiplexer reorganizes these signals, if necessary, and sends them out as directed by information in the data frames. These demultiplexed signals are sent to another regenerator and from there to the receiving STS demultiplexer, where they are returned to a format usable by the receiving links.

Terminals: A **terminal** is a device that uses the services of a SONET network. For example, in the Internet, a terminal can be a router that needs to send packets to another router at the other side of a SONET network.

Connections: The devices are connected using sections, lines, and paths.

Sections: A section is the optical link connecting two neighbor devices: multiplexer to multiplexer, Multiplexer to regenerator, or regenerator to regenerator.

Lines: A line is the portion of the network between two multiplexers: STS multiplexer to add/drop multiplexer, two add/drop multiplexers, or two STS multiplexers.

Paths: A path is the end-to-end portion of the network between two STS multiplexers. In a simple SONET of two STS multiplexers linked directly to each other, the section, line, and path are the same.

SONET LAYERS

The SONET standard includes four functional layers: the photonic, the section, the line, and the path layer. The headers added to the frame at the various layers are discussed later in this chapter. SONET defines four layers: path, line, section, and photonic.

Path Layer: The path layer is responsible for the movement of a signal from its optical source to its optical destination. At the optical source, the signal is changed from an electronic form into an optical form, multiplexed with other signals, and encapsulated in a frame. At the optical destination, the received frame is demultiplexed, and the individual optical signals are changed back into their electronic forms. Path layer overhead is added at this layer. STS multiplexers provide path layer functions.

Figure 1.22 Device-Layer Relationship in SONET

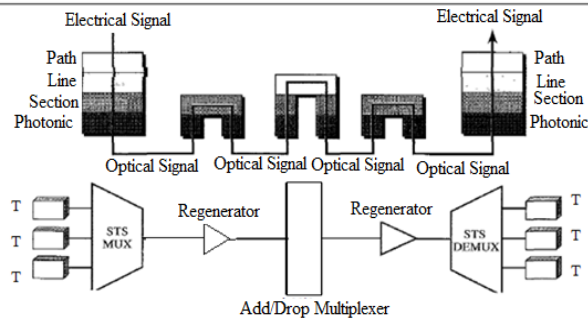

Line Layer: The **line layer** is responsible for the movement of a signal across a physical line. Line layer overhead is added to the frame at this layer. STS multiplexers and add/drop multiplexers provide line layer functions.

Section Layer: The **section layer** is responsible for the movement of a signal across a physical section. It handles framing, scrambling, and error control. Section layer overhead is added to the frame at this layer.

Photonic Layer: The **photonic layer** corresponds to the physical layer of the OSI model. It includes physical specifications for the optical fiber channel, the sensitivity of the receiver, multiplexing functions, and so on. SONET uses NRZ encoding with the presence of light representing 1 and the absence of light representing 0.

SONET FRAMES

Each synchronous transfer signal *STS-n* is composed of 8000 frames. Each frame is a two-dimensional matrix of bytes with 9 rows by $90 \times n$ columns. For example, STS-1 frame is 9 rows by 90 columns (810 bytes), and an STS-3 is 9 rows by 270 columns (2430 bytes). Figure 17.4 shows the general format of an STS-1 and an *STS-n*.

Figure 1.23 An STS-1 and STS-n Frame



A SONET *STS-n* signal is transmitted at 8000 frames per second. If we sample a voice signal and use 8 bits (1 byte) for each sample, we can say that each byte in a SONET frame can carry information from a digitized voice channel. In other words, an STS-1 signal can carry 774 voice channels simultaneously (810 minus required bytes for overhead). Each byte in a SONET frame can carry a digitized voice channel.

Wavelength division Multiplexing (WDM): A powerful aspect of an optical communication link is that many different wavelengths can be sent along a single fiber simultaneously in the 1300 to 1600nm spectral band. The technology of combining a number of wavelengths on to the same fiber is known as wavelength division multiplexing or WDM.

Features of WDM:

Capacity upgrade: If each wavelength supports an independent network signal of perhaps a few giga bits per second, then WDM can increase the capacity of fiber optic network dramatically.

Transparency: Using different wavelengths, fast (Or) slow asynchronous and synchronous digital data and analog information can be sent simultaneously and independently, over the same fiber, without the need for a common signal structure.

Wavelength routing: The use of wavelength sensitive optical routing devices makes it possible to use wavelength as another dimension, in addition to the time and space in designing communication networks and switches. In wavelength routed networks, use the actual wavelength as intermediate (or) final address.

Wavelength switching: Wavelength routed network-rigid configuration (can not be altered) Wavelength switched network (WSN)-allow the reconfiguration of optical network. Key components needed for WSN add drop multiplexed. Optical cross connects and wavelength converters.

Operation principle of WDM.

OPERATION PRINCIPLE OF WDM

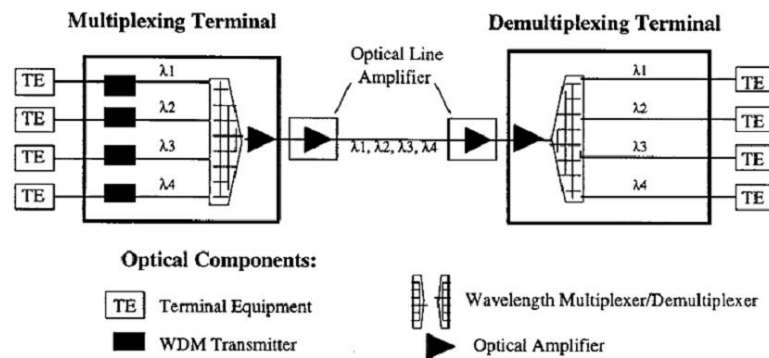

Fig.(a) A four-channel point-to-point WDM transmission system with amplifiers.

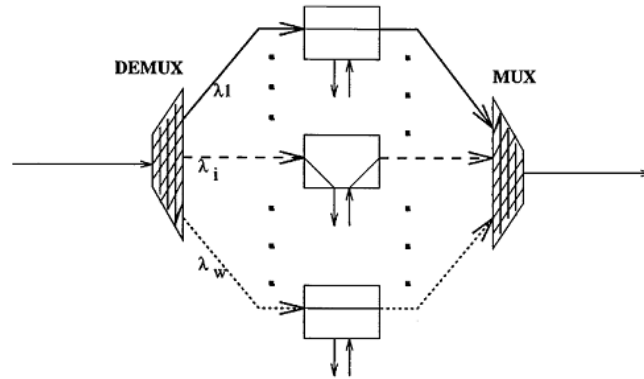

Fig. (b) A wavelength add/drop multiplexer (WADM).

- Here N fibers come together at an optical combiner (or) wavelength multiplexer, each with its energy present at different wavelength.
- The N light beams are combined (or) multiplexed on to a single shared fiber for transmission to a distance destination.
- At far end, the beam is split up over many fibers as there were on the input side. Each output fiber contains a short, specially constructed core that filters act all but one wavelength.
- The resulting signals can be routed to their destination (or) recombined in different ways for additional multiplexed transport
- The only difference with electrical FDM is that on optical system using a diffraction grating is completely passive and thus highly reliable.
- The first commercial system had eight channels of 2.5 Gpbs per channel. By 2001, there were products with 96 channels of 10 Gpbs , for a total of 960 Gpbs.
- When the number of channels is very large and wavelength is spaced close together, for example 0.1nm, the system often referred to as DWDM (Dense WDM).
- By running many channels in parallel on different wavelength, the aggregate bandwidth is increased linearly with the no. of channels. Since the bandwidth of single fiber band is about 25,000 GHZ, there is theoretically room for 2500 10 GPPS channels even at 1 bit/HZ. (for DWDM, write same explanation with the diagram)

Wavelength division Multiplexing (WDM): A powerful aspect of an optical communication link is that many different wavelengths can be sent along a single fiber simultaneously in the 1300 to 1600nm spectral band. The technology of combining a number of wavelengths on to the same fiber is known as wavelength division multiplexing or WDM.

Features of WDM:

Capacity upgrade: If each wavelength supports an independent network signal of perhaps a few giga bits per second, then WDM can increase the capacity of fiber optic network dramatically.

Transparency: Using different wavelengths, fast (Or) slow asynchronous and synchronous digital data and analog information can be sent simultaneously and independently, over the same fiber, without the need for a common signal structure.

Wavelength routing: The use of wavelength sensitive optical routing devices makes it possible to use wavelength as another dimension, in addition to the time and space in designing communication networks and switches. In wavelength routed networks, use the actual wavelength as intermediate (or) final address.

Wavelength switching: Wavelength routed network-rigid configuration (can not be altered) Wavelength switched network (WSN)-allow the reconfiguration of optical network. Key components needed for WSN add drop multiplexed. Optical cross connects and wavelength converters.

Operation principle of WDM.

OPERATION PRINCIPLE OF WDM

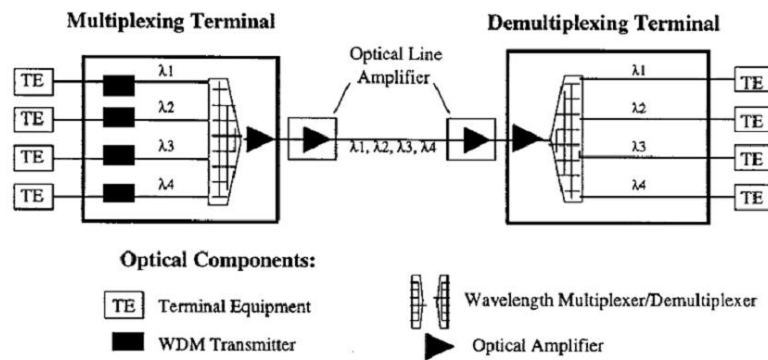

Fig.(a) A four-channel point-to-point WDM transmission system with amplifiers.

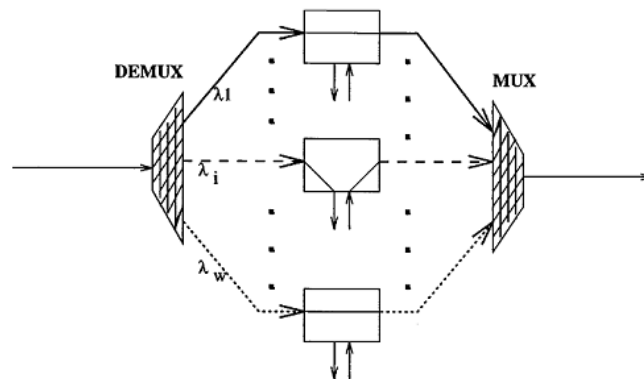

Fig. (b) A wavelength add/drop multiplexer (WADM).

- Here N fibers come together at an optical combiner (or)wavelength multiplexer, each with its energy present at different wavelength.

- The N light beams are combined (or) multiplexed on to a single shared fiber for transmission to a distance destination.
- At far end, the beam is split up over many fibers as there were on the input side. Each output fiber contains a short, specially constructed core that filters out all but one wavelength.
- The resulting signals can be routed to their destination (or) recombined in different ways for additional multiplexed transport
- The only difference with electrical FDM is that an optical system using a diffraction grating is completely passive and thus highly reliable.
- The first commercial system had eight channels of 2.5 Gbps per channel. By 2001, there were products with 96 channels of 10 Gbps, for a total of 960 Gbps.
- When the number of channels is very large and wavelength is spaced close together, for example 0.1nm, the system is often referred to as DWDM (Dense WDM).

By running many channels in parallel on different wavelengths, the aggregate bandwidth is increased linearly with the no. of channels. Since the bandwidth of a single fiber band is about 25,000 GHz, there is theoretically room for 2500 10 Gbps channels even at 1 bit/Hz. (for DWDM, write same explanation with the diagram)

- **OPTICAL CDMA TECHNIQUE** Optical code division multiple access (OCDMA) combines the beneficial aspects of optical fiber and the flexibility of the CDMA to achieve reliable high speed connectivity. CDMA was first applied to optical domain in the mid 1980s.
- The optical code division multiple access is continuously gaining more and more interest due to its potential for improved information security, simplified and decentralized network control, improved spectral efficiency and increased flexibility in the granularity of bandwidth that can be provided.
- The main difference of O-CDMA systems from wireless CDMA is the code structure. Optical systems are mainly intensity modulated and hence the chips in the O-CDMA system are alternating '1's and '0's instead of '-1's and '+1's. In an Optical CDMA system, each bit is divided up into n time's periods called chips.
- An optical signature sequence or codeword is created, by sending a short optical pulse during some chip interval but not for others. Each user on the O-CDMA system has a unique signature sequence.
- The encoder of each transmitter represents each "1" bit by sending the signature sequence whereas a binary "0" bit is represented by all zero sequence. Since each bit of the original signal is represented by a pattern of lit and unlit chips, the bandwidth of the data stream is increased

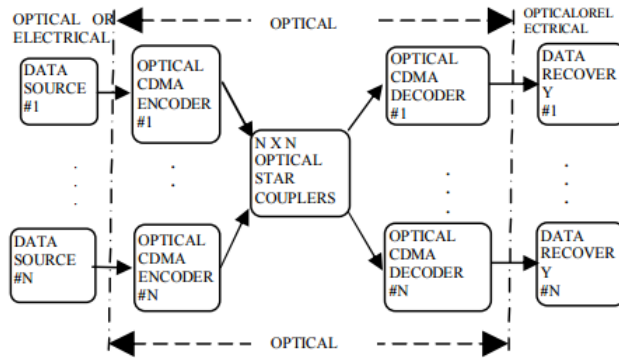

Optical CDMA is therefore a spread spectrum technique. The optical CDMA encoded data is then sent to the $N \times N$ star coupler in a local area network or $1 \times N$ coupler in an access network and broadcast to all nodes as shown in fig.

In optical CDMA, different users whose signals may be overlapped both in time and frequency share common communication medium; multiple accesses is achieved by assigning unlike minimally interfering code sequence to different transmitter, which must subsequently be detected in the presence of multiple access interference from the users.

The crosstalk between different users sharing the common fiber channel known as the multiple access interference is usually the dominant source of bit errors in an O-CDMA systems.

The intelligent design of the code word sequence is important to reduce the contribution of MAI to the total received signal. Performance of O-CDMA communications is clearly dependent on the Multiple User Interface, the type of modulation used and the receiver topology.

Coherent and Incoherent OCDMA OCDMA system can be classified as

- coherent
- incoherent

Depending on the nature of superposition of the optical signal.

Incoherent systems use intensity-modulation/direct-detection (IM-DD) receivers that detect the power of the optical signal but not the instantaneous phase variations of the optical signal. Thus uses the presence of light signal energy or no light signal energy to represent the binary “1” and “0”. Incoherent OCDMA systems use only uni-polar codes.

In coherent OCDMA system, the phase information of the optical carrier is crucial for the despreading process. It increases the complexity of receiver. However the performance of the coherent system is superior to the incoherent since the receiver are more sensitive to signal to noise ratio, which makes the overall system performance better. Early O-CDMA networks were developed based upon code

sequences of incoherent pulses and intensity modulation. The signals were therefore uni-polar with no negative components due to the incoherent nature of the system. Each user had a unique spreading sequence: coded transmission was sent to represent data bit “1” and null was used for a “0” bit. Nevertheless, the signature codes used, i.e. optical orthogonal codes (OOCs), generally had much poorer correlation properties than their bipolar counterparts, and their availability was severely restricted. Later coherent systems often relied on phase coding of the optical signal field and coherent detection. Bipolar signaling was used in the form of ‘+1’ or ‘-1’, which could be obtained by manipulating the polarization or phase of the optical coherent carrier signal. B.

A. Synchronous and Asynchronous OCDMA: The optical CDMA system may be synchronous or asynchronous.

In a synchronous OCDMA (S-OCDMA) the bit and chip are synchronized and the receiver examines the correlator output only at one instant in the chip interval. The codeset for S-OCDMA are described by the (N, w, λ) . S-OCDMA dramatically improves efficiency by trading off between code length, MAI and address space. In the asynchronous OCDMA the bit are not synchronized but the chips may be transmitted synchronously. The codeset for A-OCDMA are described as $(N, w, \lambda_a, \lambda_c)$. The cardinality of C_a for A-OCDMA can be used as a codeset of C_s with $(N, w, \max(\lambda_a, \lambda_c))$ and cardinality $|C_s| = n \cdot |C_a|$ for S-OCDMA, since each of the n time shifts of each code sequence of C_a can be used as a unique code sequence in C_s with the same correlation properties.

OCDMA for PON and LAN In data communication systems, the access network directly link with the customer premises and is responsible for delivering and collecting traffic.

Optical access network can be categories into two:

- Active optical network (AON)
- Passive optical network (PON)

In AON electrical de-multiplexer are used where as in PON optical de-multiplexer are employed. PON avoid the effect of electromagnetic interference and thunder, economize the cost of operation and maintenance, very good transparency and is suitable for signals with any format and any bit rate, thus provide improved reliable systems. In fiber-to-the-home (FTTH) application, optical access networks are considerable choice. The all optical CDMA system is usually a fiber optic non-coherent system. It usually has no separate modulation operation

The combination of three potential advantages makes OCDMA attractive from a networking perspective:

- i. Large channel count.

ii. Asynchronous transmission simplifies access control to the medium.

iii. Multiclass multi-rate services can be implemented by using variable code lengths code weight

System Parameters Various parameters to be considered in the design and implementation of OCDMA communication systems - are:-

- a) Bit rate
- b) Chip rate
- c) Power handling
- d) Processing gain
- e) Multiple access interference

OPTICAL CDMA CODING TECHNIQUE

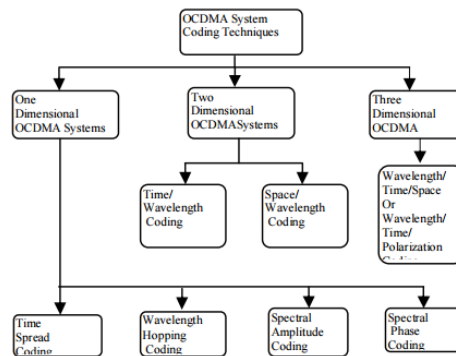

In order to implement OCDMA communication network, address codes with sufficient performance are required. OCDMA is the use of optical network technology to arbitrate channel access among multiple network nodes in a distributed fashion.

Passive Optical Network (PON):

- PON use some form of passive components such as optical star coupler or static wavelength router as the remote node.
- Simple PON architecture uses a separate fiber pair from the CO to each ONU. The main problem with this approach is that cost of CO equipment scales with the number of ONU's.
- Moreover, the operator needs to install and maintain all these fiber pairs. This type of architecture used to provide high speed service.
- Instead of providing a fiber pair to each ONU, a single fiber can be used with bidirectional transmission. However the same wavelength cannot be used to transmit data simultaneously in both the directions because of the uncontrolled reflection in the fiber. One way is to use time division multiplexing so that both the ends does not transmit simultaneously. Another is to use different wavelength (1.3 and

1.55 μm ,for example)for the different directions.

- In PON architecture,fiber pair can also shared by many users.Common example for such network is SONET/SDH rings.This type of network provides high speed services to large business customers.An ONU is a SONET add drop multiplexer(ADM),which can drop its information at particular wavelength.

PON architecture types:

- T PON-Passive Optical Network for Telephony.
- W PON-Wavelength Division Multiplexing (WDM) Passive Optical Network.
- WR PON-Wavelength Routing Passive Optical Network.

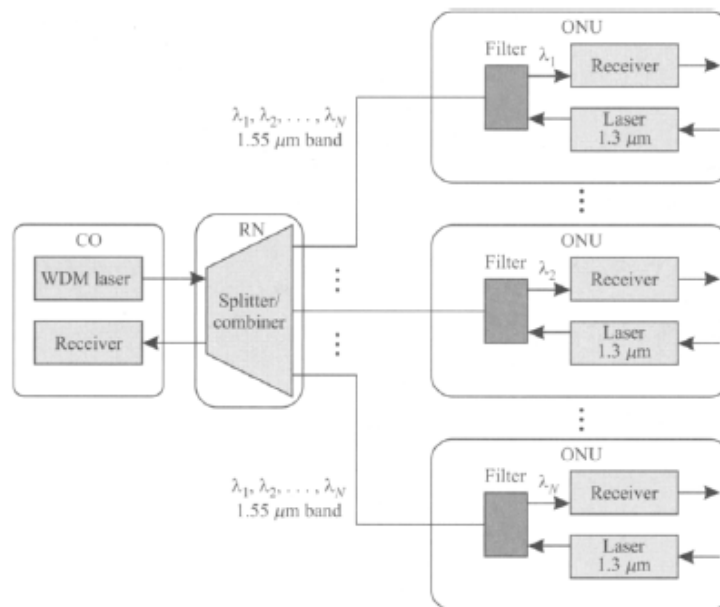

Figure 11.8 A broadcast-and-select WDM PON (WPON), which is an upgraded version of the basic PON architecture. In this case, the CO broadcasts multiple wavelengths to all the ONUs, and each ONU selects a particular wavelength. As in a conventional TPON, the ONUs time-share an upstream channel at a wavelength different from the downstream wavelengths.

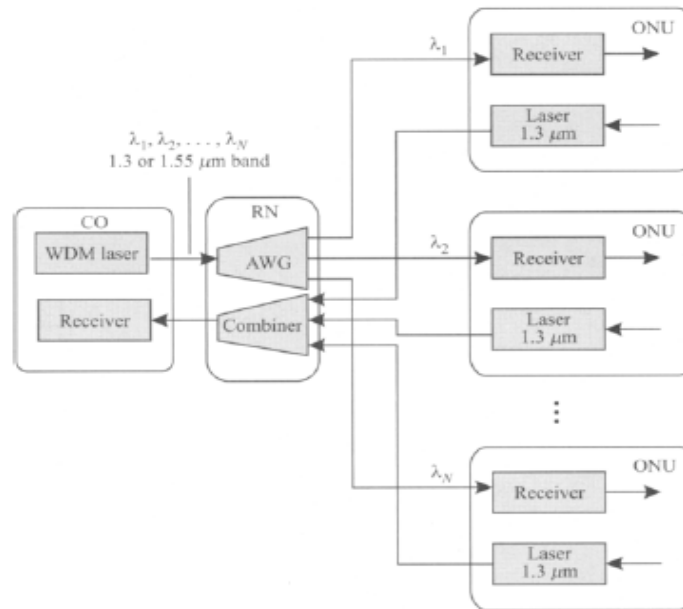

Figure 11.9 A wavelength-routing PON (WRPON). In this case, a passive arrayed waveguide grating (AWG) is used to route different wavelengths to different ONUs in the downstream direction, without incurring a splitting loss. As in the TPON and WPON architectures, the ONUs time-share a wavelength for upstream transmission.

Passive Optical Network for Telephony (TPON):

- The CO broadcasts its signal downstream to all the ONU's using a passive star coupler. The ONU shares an upstream channel in a time multiplexed fashion. In this case, upstream and downstream signals are carried using different wavelength over a single fiber.
- In TDM approach, the ONU's need to be synchronized to a common clock. This is done by a process called 'RANGING', where each ONU measures its delay from CO and adjusts its clock such that all the ONU's are synchronized relative to the CO.
- The CO transmitted can be LED or fabry penot laser and receiver is PIN FET receiver. ONU's transmitter and receiver can also be LED or laser and PIN FET receiver.
- Number of ONU's is limited by splitting loss in the star coupler.
- There is a trade off between transmitted power, receiver sensitivity, bit rate and the number of ONU's and total distance covered.
- TPON's may be cost effective at offering low speed services compared to SONET/SDH rings or Ethernet based offerings.

b.WDM PON:

- It is an upgraded version of the basic PON architecture. In this case, the CO broadcasts multiple

wavelengths to all the ONU's and each ONU select a particular wavelength.

- In this case, a single transceiver at the CO with WDM array of transmitters or single tunable transmitter to yield (WDM PON).
- This approach allows each ONU's to have electronics running only at the rate it receives data, and not at the aggregate bit rate.
- However it is still limited by the power splitting at the star coupler.

c. WR PON- Wavelength routing PON:

- In this case, a passive arrayed waveguide grating (AWG) is used to route different wavelength to different ONUS in the downstream directions, without incurring a splitting loss.
- As in the TPON and WPON architectures, the ONUS time shared wavelength for upstream transmission
- It allows point to point dedicated services to be provided to ONUS.

Disadvantages of PON:

- The cost of CO equipment scales with number of ONU's.
- Operator needs to install and maintain all the pair of fibers coming from each ONU's to CO.

Advantages of PON:

- Since this architecture is made from passive components, its reliability is very high.
- Ease of maintenance.
- Fiber infra structure itself is transparent to bit rate modulation formats and the overall network can be upgraded in the future without changing the infra structure itself.

FTTH: Fiber to the home

- IN FTTC ie Fiber to the curb (or) Fiber to the building, data is transmitted digitally over optical fiber from the hub, or central office, to fiber terminating nodes called optical network units (ONU). The expectation is that fiber would get much closer to the subscriber with this architecture.
- IN FTTH (fiber to the home) architecture, the ONUS would perform the function of NIU> Here the optical fiber is used to transmit data from central office to remote node (RN) and RN to home.
- In network from the co to ONU is typically a passive optical network (PON). The remote node is a simple passive device such as an optical star coupler and it may some be collocated in the central office itself rather than in the field.
- Although many different architectural alternatives can be used for FTTC, the term FTTC is usually used to describe a version where the signals are broadcast from the central office to the ONUS, and

the ONUS share a common total bandwidth in time division multiplexed fashion.

- In FTTC, the fiber is within about 100m of the end user. In this case, there is an additional distribution network from the ONUS to the NIUS with the fiber to the cabinet(FTTcab) approach, the fiber is terminated in a cabinet in the neighbourhood and is within about 11cm of the end user.

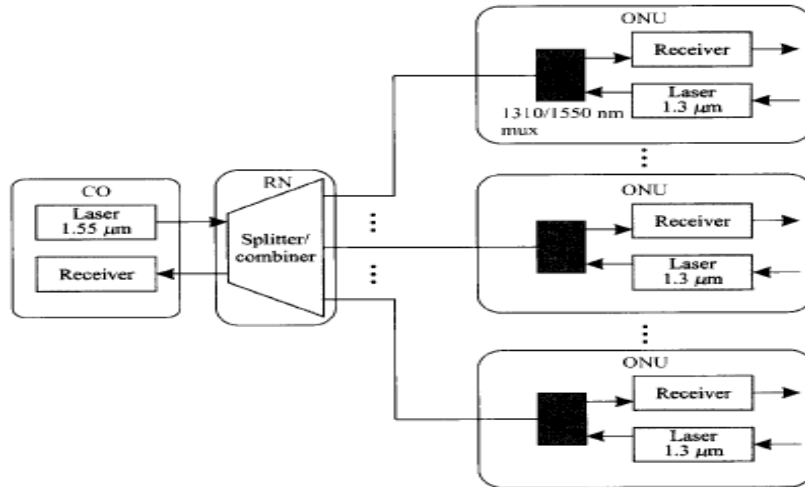

Figure 11.7 A broadcast and select TPON. The CO broadcasts its signal downstream to all the ONUs using a passive star coupler. The ONUs share an upstream channel in a time-multiplexed fashion. In this case, upstream and downstream signals are carried using different wavelengths over a single fiber.

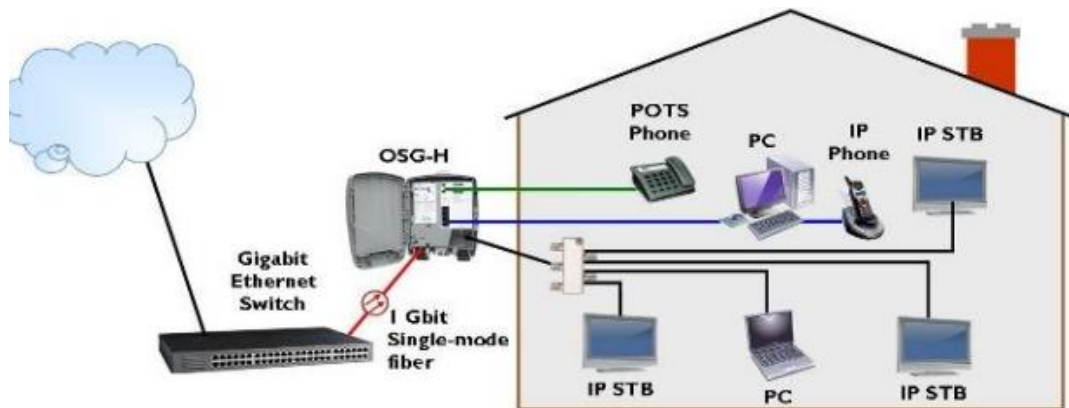

Figure. General diagram of Fiber to the home

Optical network management functions

All optical network (AON) consisting of AT&T Bell laboratories, digital equipment co-operation and Massachusetts institute of technology developed a test bed for light wave communication. the aim of the test bed was to demonstrate a single routing mode in a network operating at a transmission rate of 100 lib/s.

Packet interleaving was used and packets from electronic sources at 100 Mb/s were optically compressed to the 100 lib/s rate using optical time division multiplexing.

AON supported different classes of service, specifically guaranteed bandwidth service and bandwidth-on-demand service.

The topology used in the above diagram is bus topology where users transmit in the top half of the bus and receive from the bottom half. However, each user is attached for transmission to two points on the bus such that the guaranteed bandwidth transmission are always upstream from the bandwidth-on-demand transmission since it having helical shape, the name helical LAN(HLAN) for this network.

network management consists of several functions, all of which are important to the operation of the network:

1. Performance management deals with monitoring and managing the various parameters that measure the performance of the network. Performance management is an essential function that enables a service provider to provide quality-of-service guarantees to their clients and to ensure that clients comply with the requirements imposed by the service provider. It is also needed to provide input to other network management functions, in particular, fault management, when anomalous conditions are detected in the network.

2. Fault management is the function responsible for detecting failures when they happen and isolating the failed component. The network also needs to restore traffic that may be disrupted due to the failure, but this is usually considered a separate function.

3. Configuration management deals with the set of functions associated with managing orderly changes in a network. The basic function of managing the equipment in the network belongs to this category. This includes tracking the equipment in the network and managing the addition/removal of equipment, including any rerouting of traffic this may involve and the management of software versions on the equipment.

Another aspect of configuration management is connection management, which deals with setting up, taking down, and keeping track of connections in a network. This function can be performed by a centralized management system. Alternatively, it can also be performed by a distributed network control entity. Distributed network control becomes necessary when connection setup/take-down events occur very frequently or when the network is very large and complex.

Finally, the network needs to convert external client signals entering the optical layer into appropriate signals inside the optical layer. This function is adaptation management.

4. Security management includes administrative functions such as authenticating users and setting attributes such as read and write permissions on a per-user basis. From a security perspective, the network is usually partitioned into domains, both horizontally and vertically. Vertical partitioning implies that some users may be allowed to access only certain network elements and not other network elements.

- For example, a local craftsman may be allowed to access only the network elements he is responsible for and not other network elements. Horizontal partitioning implies that some users may be allowed to access

some parameters associated with all the network elements across the network.

- For example, a user leasing a lightpath may be provided access to all the performance parameters with that lightpath across all the nodes that the light path traverses. Security also involves protecting data belonging to network users from being tapped or corrupted by unauthorized entities. This part of the security function needs to be handled by encrypting the data before transmission and providing the decrypting capability to legitimate users.

5. Accounting management is the function responsible for billing and for developing lifetime historical records of network components. This function is the same for optical networks.